

Operation Guide

ECOSYS MA4000wfx ECOSYS MA4000x

2024.09
C1CCKDENUS000



Contents

1	Please Read First.....	1
	Preface	2
	Machine Features	3
	Optimize your office workflow	3
	Save energy and cost	5
	Create attractive documents	6
	Strengthen security	7
	Use functions more efficiently	9
	Color and Image Quality Functions.....	11
	Basic Color Modes	11
	Adjusting Image Quality and Color	12
	Guides Provided with the Machine	14
	About the Operation Guide (this Guide).....	16
	Structure of the guide	16
	Conventions Used in This Guide	17
	Notice.....	21
	Safety Conventions in This Guide	21
	Environment	22
	Precautions for Use	23
	SAFETY OF LASER BEAM (USA).....	24
	Safety Instructions Regarding the Disconnection of Power.....	25
	Compliance and Conformity.....	26
	Other precautions (for users in California, the United States).....	28
	Warranty (the United States and Canada)	29
	Legal Restriction on Copying/Scanning	30
	Wireless Connection	31
	Security Precautions when Using Wireless LAN (If equipped)	32
	Limited Use of This Product.....	33
	Legal and Safety Information.....	34
	Energy Saving Control Function.....	37
	Automatic 2-Sided Print Function	38
	Resource Saving - Paper	39
	Environmental benefits of "Power Management"	40
	ENERGY STAR Program.....	41
	Precautions for security when using wireless LAN.....	42
2	Installing and Setting up the Machine	43
	Part Names (Machine Exterior).....	44
	Part Names (Connectors/Interior).....	46
	Part Names (With Optional Equipments Attached).....	48
	How to hold the device	49
	Connecting the Machine and Other Devices	50
	Connecting Cables.....	52
	Connecting LAN Cable.....	52
	Connecting USB Cable.....	53
	Connecting the Power Cable	54
	Power On/Off	55
	Power on	55
	Power off.....	56
	Using the Operation Panel	57
	Operation Panel Keys	57
	Using the Operation Panel	60
	Help Screen.....	62
	Login/Logout.....	63
	Login.....	63

Log in by ID card	64
Log in using a keyboard.....	65
Logout	66
Default Settings of the Machine	67
Setting Date and Time.....	67
Network Setup.....	69
Energy Saver function	81
Installing Software	86
Published Software (Windows).....	86
Published Software (Mac)	88
Installing Software in Windows.....	89
Uninstalling Windows Software	96
Installing Software on a Mac OS Computer	98
Configure TWAIN Driver.....	103
Configure WIA Driver.....	105
Check the counter	107
Additional Preparations for the Administrator	108
Administrator Privileges Overview	108
Log in as Machine Administrator or Administrator	109
Strengthening the Security.....	110
What is Command Center RX.....	112
Accessing Command Center RX.....	113
Changing Security Settings.....	114
Changing Device Information	115
SMTP and E-mail Settings	116
Registering Destinations.....	120
Transferring Data from Our Other Products.....	121
Migrating the Address Book.....	121

3 Preparation before Use.....129

Load paper	130
Loading Paper	130
Precaution for Loading Paper	131
Paper Specifications available in the Cassettes	132
Loading in the Cassettes.....	133
Paper Specifications available in the Multipurpose Tray	137
Loading Paper in the Multipurpose Tray	138
Specifying Paper Size and Media Type	140
Paper Stopper	142
Preparation for Sending a Document to a Shared Folder in a PC.....	143
Make a note of the computer name and full computer name	143
Make a note of the user name and domain name	144
Create a shared folder and make a note of the shared folder name.....	145
Configuring Windows Firewall	150
Scan to Folder Setup Tool for SMB.....	155
Registering Destinations in the Address Book	161
Adding a Destination (Address Book).....	161
Add One Touch Keys.....	172

4 Print from PC.....175

Printer Driver Print Settings Screen	176
Displaying the Printer Driver Help.....	177
Changing the Default Printer Driver Settings (Windows 2016 and later).....	178
Changing the Default Printer Driver Settings (Windows 11).....	179
Printing from PC	180
Printing on Standard Sized Paper.....	180
Printing on Non-standard Sized Paper	182
Printing with Universal Print	185
Canceling Printing from a Computer	189

Printing from the Mobile Device.....	190
Printing by AirPrint	190
Printing by Mopria	191
Printing with Wi-Fi Direct	192
Printing Data Saved in the Printer.....	193
Specifying the Job Box from a Computer and Storing the Job	193
Printing Documents from Private Print Box.....	195
Deleting the Documents Stored in the Private Print Box	196
Printing Document from Stored Job Box	197
Deleting the Documents Stored in the Stored Job Box.....	199
Printing Document from Quick Copy Box.....	200
Deleting the Documents Stored in the Quick Copy Box	201
Printing Document from Proof and Hold Box.....	202
Deleting the Documents Stored in the Proof and Hold Box.....	203
Printing Documents from PIN Print Box.....	204
Deleting the Documents Stored in the PIN Print Box	205
Printing Document from Universal Print Box.....	206
Deleting the Documents Stored in the Universal Print Box	208
Job Box Settings	209
Monitoring the Printer Status (Status Monitor).....	210
Accessing the Status Monitor.....	210
Exiting the Status Monitor	211
Quick View State.....	212
Printing progress tab.....	213
Paper tray status tab	214
Toner Status Tab.....	215
Alert tab.....	216
Status Monitor Context Menu	217
Status Monitor Notification Settings	218

5 Operation on the Machine220

Loading Originals	221
Placing Originals on the Platen.....	221
Original Specifications available in the Document Processor.....	223
Recalling Frequently Used Functions (Program 1)	226
Register the program	226
Recall the program	228
overwrite the program.....	229
Delete the program	230
Selection key settings.....	231
Copying.....	232
Copy.....	232
Canceling Jobs	233
Basic Scanning (Sending).....	234
Sending Document via E-mail.....	235
Sending Document to Desired Shared Folder on a Computer (Scan to PC)	236
Sending Document to Folder on an FTP Server (Scan to FTP)	238
Scanning using TWAIN or WIA.....	240
Useful Sending Method	241
WSD Scan.....	242
Install the Driver (for Windows 10).....	242
Install the Driver (for Windows 11).....	243
Executing WSD scan	244
Sending to different types of destinations (Multi sending).....	245
Sending to different types of destinations	245
Sending Documents to E-mail Address of Logged in User (to myself).....	247
Using a Fax Server to Send (Fax Server Send)	248
Canceling Sending Jobs	250
Handling Destination	251
Specifying Destination	251

Choosing from the Address Book.....	252
Choosing from the External Address Book.....	253
Choosing from One Touch key destinations	254
Checking and Editing Destinations.....	255
Confirmation Screen of Destinations	256
Re-entering the New Destination	257
Recall	258
How to use the FAX Function	259
Using Document Boxes	260
What is Job Box?.....	260
What is USB Drive Box?.....	261
What is a Fax Memory RX Box/Subaddress Box/Polling Box?.....	262
Using Removable USB Drive	263
Printing Documents Stored in Removable USB Drive	263
Saving Documents to USB Drive (Scan to USB).....	265
Check the USB Drive Information.....	267
Removing USB Drive.....	268
Cloud Linkage Function	269
Set up files and folders in a cloud service.....	269
Installing Kyocera Cloud Access.....	270
Set Kyocera Cloud Access user account (authorization information).	271
Linkage with the Cloud Service	273
Scan and Print using the Cloud Service	274

6 Using Various Functions276

About Functions Available on the Machine.....	277
Select a function menu.	277
Copy.....	278
Send.....	280
USB Drive (Store File, Printing Documents).....	283
Functions	286
Original Size.....	286
Paper Selection	287
Mixed Size Orig.	289
Orig.Orientation	291
Collate.....	292
ID Card Copy.....	293
Density	294
Original Image	295
EcoPrint	297
Color Selection	298
Sharpness	299
Backgrnd Density.....	300
Saturation	301
Prevent Bleed-t.....	302
Contrast.....	303
Erase Colors	304
Zoom	305
Combine.....	308
Border Erase	311
DuplexDuplex.....	314
Continuous Scan	318
JobFinish Notice.....	319
File Name Entry	320
Priority Override.....	321
FoldingDetection.....	322
Skip Blank Page.....	323
Duplex	324
Sending SizeSending Size	325
File Format.....	327

File Separation.....	334
Scan Resolution.....	335
Clarify Text (Noise Removal).....	336
Subject/Body	337
FTP Encrypted TX	338
EmailEncryptedTX.....	339
DigitalSignature	340
Storing Size.....	342
Encrypted PDF.....	343
JPEG/TIFF Print.....	344
XPS FitTo Page.....	345

7 Status/Job Cancel.....346

Checking Job Status.....	347
Displaying Status Screens.....	347
Details of the Status Screens.....	349
Checking Job History.....	355
Displaying Job History Screen	356
Sending the Log History.....	360
Job Operation.....	361
Pause and Resumption of Jobs	361
Canceling of Jobs.....	362
Check the device information	363
Checking the Remaining Amount of Toner and Paper, and the Condition of the Unit.....	364

8 System Menu.....365

Operation Method.....	366
System Menu Settings	367
[Report].....	369
[Report Print].....	369
[Admin Rpt Set.]	370
[Result Rpt Set.].....	371
[Jobs Log]	372
History Management.....	373
[Counter].....	374
[System/Network].....	375
[Network Setting].....	375
[User/Job Account]	422
[User Property]	424
[Common Settings]	425
[Language].....	426
[Default Screen].....	427
[Sound].....	428
[Display Bright.].....	429
[Media Type Set.].....	430
[Orig./Paper Set.]	432
[Paper Setup Msg]	437
[Preset Limit]	438
[Measurement].....	439
[Error Handling]	440
[Date/Time].....	441
[Timer Setting].....	442
[Function Default].....	445
[Login Operation].....	452
[RAM Disk Mode].....	453
[Format SD Card].....	454
[Disp. Status/Log].....	455
[Keyboard Lang.].....	456

[Keyboard Type]	457
[Low Toner Alert].....	458
[MaintenanceAlert]	459
[Remote Printing].....	460
[Direct PRN (Web)]	461
[Show PowerOffMsg].....	462
[EnergySaver Set.].....	463
[Pause/Resume Set].....	464
[CloudConnectSet.]	465
[Copy].....	466
[Printer].....	467
[Send]	470
[FAX]	473
[Document Box].....	474
[Application]	475
[Edit Destination].....	476
[Adjust/Maint.]	478

9 User Authentication and Accounting (User Login, Job Accounting)481

Overview of User Login Administration.....	482
Managing the Job Account from PC	482
Enable User Login Administration.....	484
Setting User Login Administration	485
Authentication Security.....	485
Adding a User (Local User List)	487
Change the user properties.....	491
Deleting a user.	493
Managing the Users that Print on This Machine from a PC	494
Managing the Users that Send Faxes from a PC.....	496
Managing the Users to Scan Using TWAIN.....	497
Managing the Users to Scan Using WIA	498
Local Authorization.....	499
Server Settings	500
Configure Network User Rights	501
Group Authorization Settings.....	502
Guest Authorization Settings	503
Obtain NW User Property	506
IC Card Authentication Kit Settings	507
ID Card Settings	510
PIN Login.....	513
Using User Login Administration.....	514
Overview of Job Accounting	515
Enable job accounting	517
Job Accounting.....	518
Set the Job Accounting(Local)	519
Adding an Account.....	519
Restricting the Use of the Machine	520
Editing an Account.....	521
Deleting an Account	522
Job Accounting for Printing	523
Job Accounting for Scan Using TWAIN	525
Job Accounting for Scan Using WIA.....	526
Job Accounting for the FAX Transmitted from a Computer	527
Configuring Job Accounting	528
Default Counter Limit.....	528
Counting the Number of Pages Printed	530
Print Accounting Report.....	532
Using Job Accounting	533
Apply Limit	535

Copier/Printer Count	536
Unknown User Settings	537

10 Troubleshooting539

Regular Maintenance	540
Cleaning	540
Cleaning Platen	541
Cleaning Slit Glass.....	542
Clean the inside of the main unit.....	543
Replacing the Toner Container.....	547
Troubleshooting	551
Solving Malfunctions	551
Machine Operation Trouble.....	552
Printed Image Trouble	601
Remote Operation	625
Responding to Messages.....	628
List of Transmission Error Codes	684
Adjustment/Maintenance.....	738
Overview of Adjustment/Maintenance	738
Perform image adjustment	739
Clearing Paper Jams	740
Jam Location Indicators	740
Remove any jammed paper in the Multipurpose Tray.....	742
Remove paper jams from Cassette 1 to Cassette 3.....	743
Remove the paper jammed inside the machine.....	745
Remove any jammed paper in Rear Cover and Duplex Unit.....	750
Remove any jammed paper in the Document Processor (Reverse Automatic)....	753

11 Appendix.....755

Optional Equipment.....	756
Option configuration	756
Overview of the Applications	759
Starting Application Use	759
Checking Details of Application	760
Character Entry.....	761
Key used.....	761
Character Entry Selection.....	763
Entering numbers and alphabets.....	764
Entering Symbols.....	765
Entering Characters.....	766
In the login operation settings, select and enter[Text].....	768
About Paper	769
Basic Paper Specifications	769
Choosing the Appropriate Paper	770
Special Paper	773
Specifications	783
Machine.....	783
Copy Functions.....	785
Printer Function	786
Scanner Functions	787
Document Processor	788
Paper Feeder (300 250 sheet x 2).....	789
Backing up your data	790
Backing up your data using KYOCERA Net Viewer	790
Backing up your date using USB Drive	791
Security Quick Setup Function List.....	792
TLS.....	792
Serverside Settings	793
Clientside Settings	794

IPv4 Settings (Wired Network)	795
IPv4 Settings (Wireless Network)	796
IPv6 Settings (Wired Network)	797
IPv6 Settings (Wireless Network)	798
Send Protocols: FTP Client (Transmission)	799
Other Protocols: HTTP (Client).....	800
Other Protocols: SOAP.....	801
Other Protocols: LDAP.....	802
Send Protocols: SMTP (E-mail TX).....	803
Email: POP3 User Settings	804
Print protocols.....	805
Send Protocol	807
Other Protocols	808
TCP/IP: Bonjour Settings.....	810
Network Settings	811
Connectivity	812
Interface Block Setting	813
Energy Saver/Timer	814
User Account Lockout Setting	815
Job Status/Job Logs Settings.....	816
Edit Restriction	817
Prevent Mis-sending Settings.....	818

1 Please Read First

Preface

Thank you for purchasing this machine.

This Operation Guide is intended to help you operate the machine correctly, perform routine maintenance, and take simple troubleshooting measures as needed so that the machine can always be used in the optimum condition.

Please read this Operation Guide before using the machine.

The product illustrations, screens, settings, etc., in this guide may differ depending on the machine you are using.

We recommend the use of our genuine toner containers, which have passed rigorous quality control testing, to maintain quality.

The use of non-genuine toner containers may cause failure.

We will not be liable for any damages caused by the use of third party supplies in this machine.

A label is affixed to our genuine supplies, as shown below.

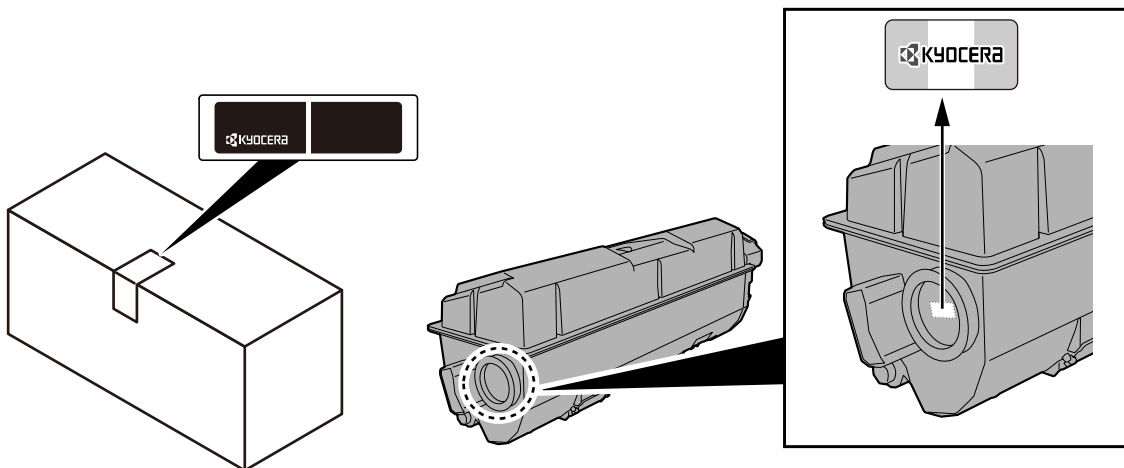

Checking the Equipment's Serial Number

The equipment's serial number is printed in the location shown in the figure.

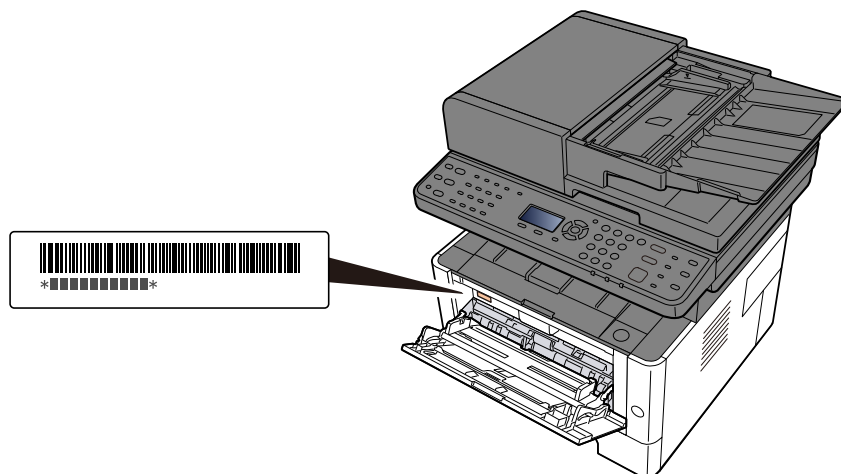

You'll need the equipment's serial number when contacting your Service Representative. Please check the number before contacting your service representative.

Machine Features

The machine is equipped with many useful functions.

➔ [Using Various Functions \(page 276\)](#)

Here are some examples.

Optimize your office workflow

Access to frequently used functions with just one touch (Program)

You can preset frequently used functions. Once you register frequently used settings as a program, you can call up the settings simply by selecting the program number. Using this favorite brings the same results even if operated by another person.

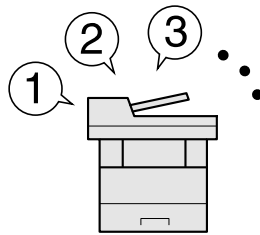

➔ [Recalling Frequently Used Functions \(Program 1\) \(page 226\)](#)

Scan originals of different sizes at a time (Mixed Size Originals)

It is useful when preparing conference materials.

You can set the different sized originals at one time so you don't need to reset the originals regardless of size.

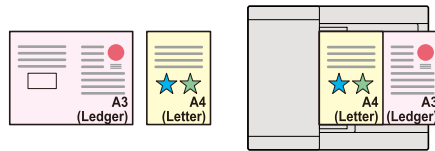

➔ [Mixed Size Orig. \(page 289\)](#)

Scan a large number of originals in separate batches and produce as one job (Continuous Scan)

It is useful when preparing many-page handouts.

When a large number of originals cannot be placed in the document processor at one time, the originals can be scanned in separate batches and then copied or sent as one job.

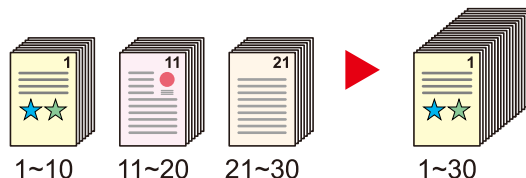

➔ [Continuous Scan \(page 318\)](#)

Send one time with multiple sending options (Multi Sending)

You can send a same document to the multiple destinations using a different method.

You can specify multiple destinations of different send methods such as Email, SMB, and Fax.

You can reduce your workflow by sending a job at once.

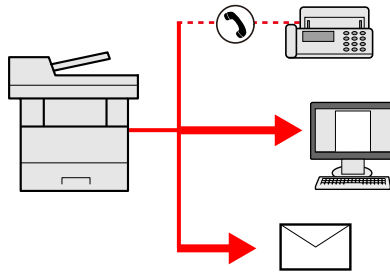

➔ [Sending to different types of destinations \(Multi sending\) \(page 245\)](#)

Save energy and cost

Save energy as needed (Energy Saver function)

The machine is equipped with Energy Saver function that automatically switches the machine into Sleep Mode. You can set appropriate Energy Saver Recovery Level depending on the operation. In addition, the machine can automatically be switched into Sleep and recovered at a specified time for each day of the week.

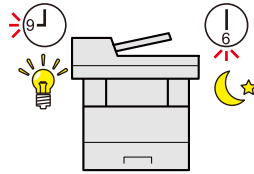

→ [Energy Saver function \(page 81\)](#)

Printing with reduced toner consumption (EcoPrint)

You can save toner consumption with this function.

When you only need to check the printed content, such as a trial print run or documents for internal confirmation, use this function to save toner.

Use this function when a high-quality print is not required.

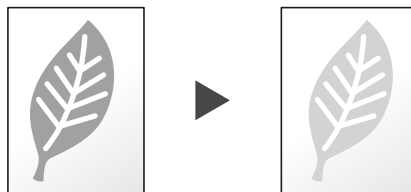

→ [EcoPrint \(page 297\)](#)

Reduce paper use (Paper Saving Printing)

You can print originals on both sides of the paper. You can also print multiple originals onto one sheet.

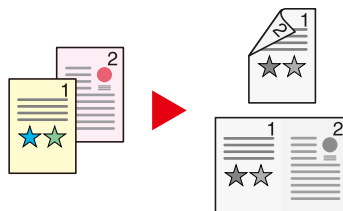

→ [Combine \(page 308\)](#)

→ [DuplexDuplex \(page 314\)](#)

Skip blank pages when printing (Skip Blank Page)

When there are blank pages in a scanned document, this function skips the blank pages and prints only pages that are not blank.



→ [Skip Blank Page \(page 323\)](#)

Create attractive documents

Prevent image bleed-through (Prevent Bleed-through)

Hides background colors and image bleed-through when scanning thin original.

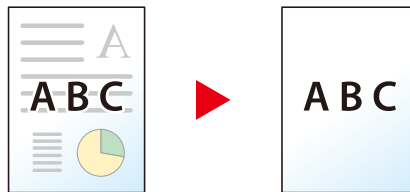

➔ [Prevent Bleed-t \(page 302\)](#)

Strengthen security

Password-protect a PDF file (PDF Encryption Functions)

Use the PDF format's password security options to restrict document viewing, printing and editing.

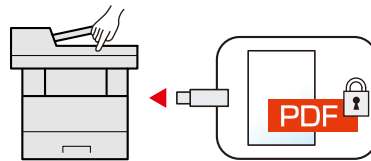

➔ [PDF Encryption Functions \(page 329\)](#)

Prevent loss of finished documents (Private Print)

Temporarily saving print jobs in the main unit document box and outputting them when in front of the device can prevent documents from being taken by others.

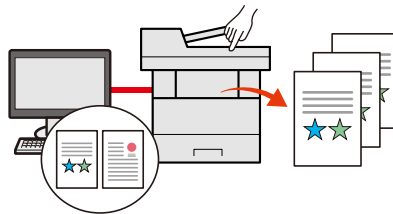

➔ [Printing Documents from Private Print Box \(page 195\)](#)

Log in by ID card (Card Authentication)

You can log in simply by touching an ID card. You don't need to enter your user name and password.

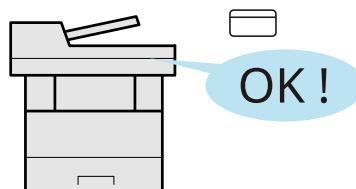

➔ [Overview of the Applications \(page 759\)](#)

Strengthen security (Settings for Administrator)

Various functions are available for administrators to strengthen security.

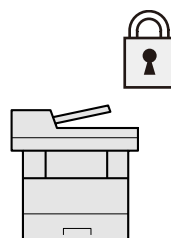

➔ [Strengthening the Security \(page 110\)](#)

Prevent the execution of malware (Allowlisting)

Prevent malware from running and prevent software tampering and maintain system reliability.

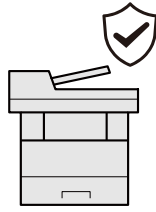

Use functions more efficiently

Make the machine quiet (Quiet Mode)

You can make the machine quiet by reducing its running noise. You can switch ON/OFF with one touch.

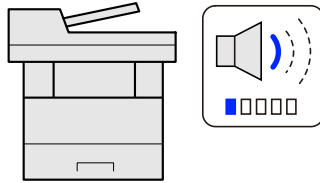

➔ [Use the quiet mode. \(page 85\)](#)

Expand functions as necessary(Application)

The functionality of the machine can be expanded by installing applications.

Applications that help you perform your daily more efficiently such as a scan feature and an authentication feature are available.

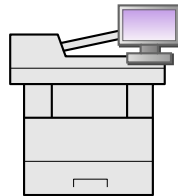

➔ [Overview of the Applications \(page 759\)](#)

Install the machine without concerning the network cables (Wireless Network)

If there is a wireless LAN environment, it is possible to install the unit without worrying about the network wiring. In addition, Wi-Fi Direct, etc. are supported.

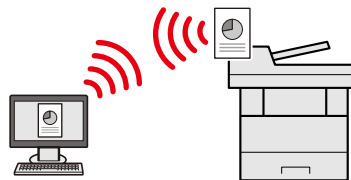

➔ [Configuring the Wireless Network \(page 71\)](#)

Use USB drive(USB Drive)

It is useful when you need to print documents outside your office or you cannot print documents from your PC.

You can print the document from the USB drive by plugging it directly into the machine.

Original scanned at the machine can be saved in the USB drive also.

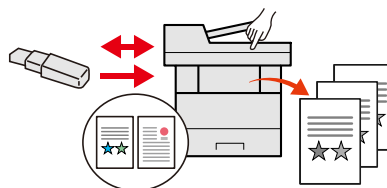

➔ [Using Removable USB Drive \(page 263\)](#)

➔ [Saving Documents to USB Drive \(Scan to USB\) \(page 265\)](#)

Specify image file format (File Format)

You can select the various file formats when sending/storing images.

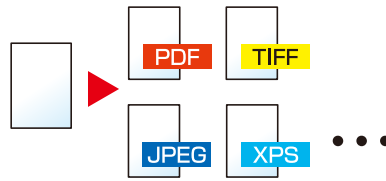

➔ [File Format \(page 327\)](#)

Detect originals with bent corners (Detection of originals with bent corners)

When scanning a document from the document processor, scanning is automatically stopped when a document with a folded corner is detected.



➔ [FoldingDetection \(page 322\)](#)

Perform remote operation (Command Center RX)

You can access to the machine remotely to print, send or download data.

You can access to the machine remotely to print data.

Administrators can configure the machine behavior or management settings.

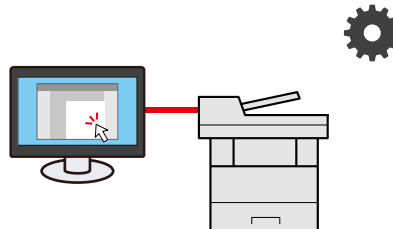

➔ [What is Command Center RX \(page 112\)](#)

Color and Image Quality Functions

The machine is equipped with various color and image quality functions. You can adjust the scanned image as desired.

Basic Color Modes

The basic color modes are as follows.

Auto Color

Automatically recognizes whether a document being scanned is color or black & white.

Reference Image

Before	After
	

Full Color

Scans the document in full color.



Reference Image

Before	After
	

Grayscale

Scans a document in grayscale.

Reference Image

Before	After
	

Black and White

Scans the document in black and white.

Reference Image

Before	After
	



For details, refer to the following.

➔ [Color Selection \(page 298\)](#)

Adjusting Image Quality and Color

To adjust the image quality or color of an image, use the following functions.









Adjust the color precisely

I want to...	Sample image (before)	Sample image (after)	Function
Adjust the density.			Density

For details, refer to the following:

➔ [Density \(page 294\)](#)

Adjust the image quality precisely

I want to...	Sample image (before)	Sample image (after)	Function
Emphasize or blur the image outline. Example: Emphasize the image outlines			Sharpness
Adjust the difference between dark and light parts of the image.			Contrast
Darken or lighten the background (the area with no texts or images) of a document. Example: Lightening the background			Background Density
Prevent bleed-through in 2-sided originals.			Prevent Bleed through

For details, refer to the following:

➔ [Sharpness \(page 299\)](#)

➔ [Contrast \(page 303\)](#)

➔ [Backgrnd Density \(page 300\)](#)

➔ [Prevent Bleed-t \(page 302\)](#)

Adjust the scanned image

I want to...	Sample image (before)	Sample image (after)	Function
Decrease the file size and produce the characters clearly.	Copy	Copy	File format

For details, refer to the following:

➔ [File Format \(page 327\)](#)

Guides Provided with the Machine

The following guides are provided with the machine. Refer to each guide as needed. The guides can be downloaded from the Download Center (<https://kyocera.info/>). To view the guides on a computer, Adobe Reader Version 8.0 or later needs to be installed.

The contents of the guides are subject to change without notice for the purpose of improvement of machine performance.

To set up the machine:	<p>Setup Guide</p> <p>Explains the setup procedure to follow in order to print with this machine.</p> <p>This printed guide is provided together with the machine.</p>
Start using the machine quickly	<p>Quick Guide</p> <p>Describes frequently-used operations and what to do when problems occur.</p>
For safe use of the machine	<p>Safety Guide</p> <p>Provides safety and cautionary information for installation environment and use of the machine. Be sure to read this guide before using the machine.</p> <p>This printed guide is provided together with the machine.</p> <p>Safety Guide (ECOSYS MA4000x/ECOSYS MA4000wfx)</p> <p>Indicates the space required for machine installation, and describes the cautionary labels and other safety information. Be sure to read this guide before using the machine.</p> <p>This printed guide is provided together with the machine.</p>
Use the machine to its fullest	<p>Operation Guide (this guide)</p> <p>Explains how to load paper and perform copy, print and scan operations, and indicates default settings and other information.</p>
Use the fax functions	<p>FAX Operation Guide</p> <p>Explains how to use the fax function.</p>
Easily register machine information and configure settings	<p>Command Center RX User Guide</p> <p>Explains how to access the machine from a Web browser on your computer to check and change settings.</p>
Print data from a computer	<p>Printer Driver User Guide</p> <p>Explains how to install the printer driver and use the printer function.</p> <p>MAC Driver Setup Guide</p> <p>Explains how to install the Mac printer driver and use the printer function (print panel).</p>
Monitor the machine and printers on the network	<p>KYOCERA Net Viewer User Guide</p> <p>Explains how to monitor your network printing system (the machine) with KYOCERA Net Viewer.</p>
Scan images and save with information	<p>File Management Utility User Guide</p> <p>Explains how to use File Management Utility to set various parameters and send and save scanned documents.</p>

Print without using the printer driver	PRESCRIBE Commands Command Reference Describes the native printer language (PRESCRIBE commands). PRESCRIBE Commands Technical Reference Describes the PRESCRIBE command functions and control for each type of emulation.
Directly print a PDF file	KYOCERA Net Direct Print Operation Guide Explains how to print PDF files without launching Adobe Acrobat or Reader.
Adjust the print or scan position	Maintenance Menu User Guide Maintenance Menu provides the explanation on how to configure the print, scan, and other settings
Scan and print through the cloud service	Kyocera Cloud Access User Guide This section explains how to install Kyocera Cloud Access and setting procedures for linking with the cloud service.

About the Operation Guide (this Guide)

Structure of the guide

The Operation Guide contains the following chapters.

Chapter	Description
Please Read First	Provides precautions regarding use of the machine and trademark information.
Installing and Setting up the Machine	Explains part names, cable connections, installation of the software, login, logout, and other matters related to administration of the machine.
Preparation before Use	Explains preparations and settings that are required in order to use the machine, such as how to load paper and create an address book.
Print from PC	Explains the basic printing method.
Operation on the Machine	Explains the basic procedures for using the machine, such as placing originals, making copies, sending documents, and using document boxes.
Using Various Functions	Explains convenient functions that are available on the machine.
Status/Job Cancel	Explains how to check the status of a job and the job history, and how to cancel jobs being printed or waiting to print. Also explains how to check paper and toner levels, how to check the device status, and how to cancel fax transmission.
System Menu	Explains System Menu and how it relates to the operation of the machine.
User Authentication and Accounting (User Login, Job Accounting)	Explains user login and job accounting.
Troubleshooting	Explains what to do when toner runs out, an error is displayed, or a paper jam or other problem occurs.
Appendix	Describes convenient options that are available for the machine. Provides information on media types and paper sizes, and gives a glossary of terms. Explains how to enter characters, and lists the specifications of the machine.

Conventions Used in This Guide

Adobe Reader is used as an example in the explanations below.

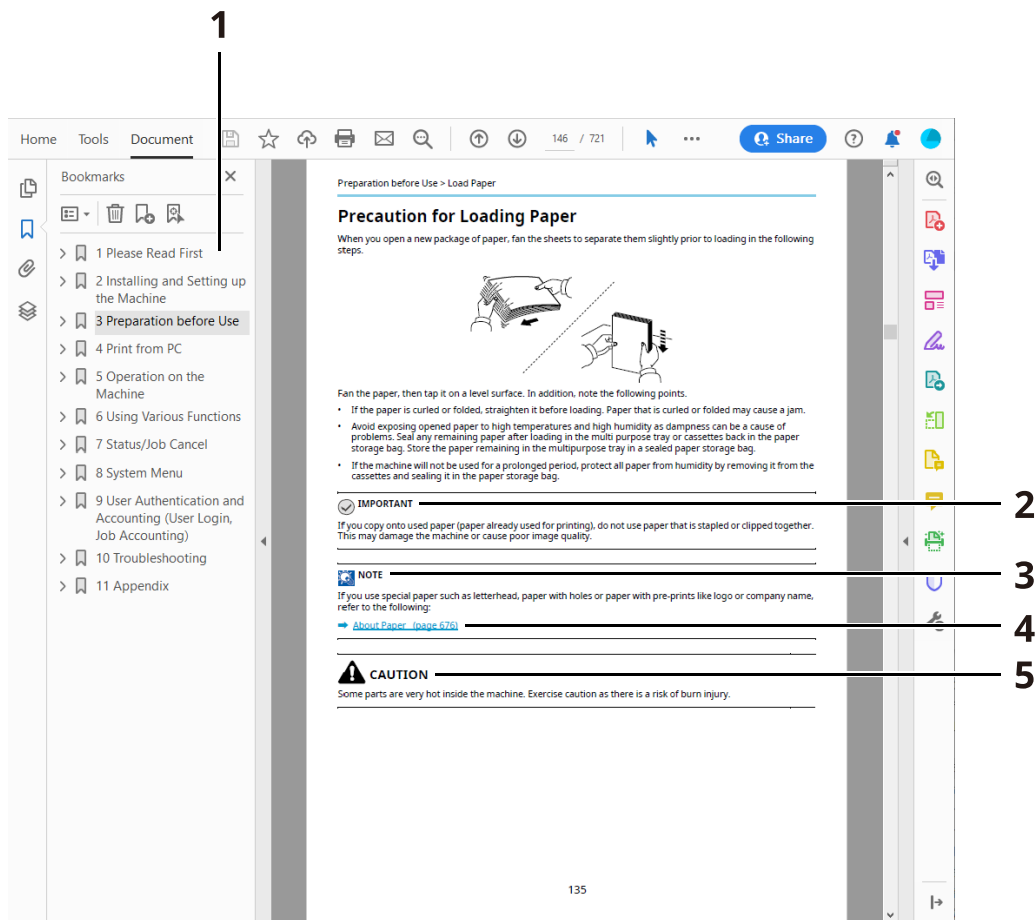

- 1 Click an item in the Table of Contents to jump to the corresponding page.
- 2 Indicates operational requirements and restrictions to operate the machine correctly, and avoid damage to the machine or property.
- 3 Indicates supplemental explanations and reference information for operations.
- 4 Click the underlined text to jump to the corresponding page.
- 5 Indicates that personal injury or mechanical damage may result from insufficient attention to or incorrect compliance with the related points.

NOTE

The items that appear in Adobe Reader vary depending on how it is used. If the Table of Contents or tools do not appear, refer to Adobe Reader Help.

Certain items are indicated in this guide by the conventions described below.

Convention	Description
[]	Indicates keys and buttons.
" "	Indicates a message.

Conventions Used in Procedures for Operating the Machine

In this Operation Guide, continuous operation is shown as below.

Actual procedure

- 1 Select the [System Menu/Counter] key.
- 2 Press the [▲][▼] key and select [Common Settings].
- 3 Select the [OK] key.

Procedure indicated in this guide



[System Menu/Counter] key > [▲][▼] keys > [Common Settings] > [OK] key

Size of Paper

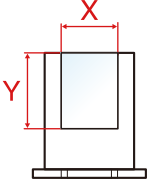

Paper sizes such as A5 and Statement can be used in both the horizontal and vertical orientations. To distinguish the orientations when these sizes are used, "R" is added to sizes used in the horizontal orientation.

Set the paper in vertical orientation

When loading in a cassette

Setting Position (X=Width, Y=Length)	Icon on the touch panel	Indicated size in this Guide
		A5-R, Statement-R

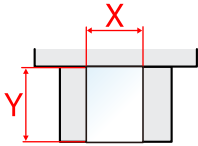
When loading in the multipurpose tray



Setting Position (X=Width, Y=Length)	Icon on the touch panel	Indicated size in this Guide
		A5-R, Statement-R

Paper sizes that can be used vary depending on the function and paper feeder unit. For details, refer to the following.

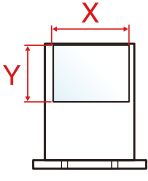

➔ [Specifications \(page 783\)](#)

Set the paper in horizontal orientation

When loading in a cassette

Setting Position (X=Width, Y=Length)	Icon on the touch panel	Indicated size in this Guide
		A5, Statement

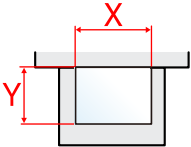
When loading in the multipurpose tray

Setting Position (X=Width, Y=Length)	Icon on the touch panel	Indicated size in this Guide
		A5, Statement

Paper sizes that can be used vary depending on the function and paper feeder unit. For details, refer to the following.

➔ [Specifications \(page 783\)](#)

Notice

Safety Conventions in This Guide

The sections of this guide and parts of the machine marked with symbols are safety warnings meant to protect the user, other individuals and surrounding objects, and ensure correct and safe usage of the machine. The symbols and their meanings are indicated below.



WARNING:

Indicates that serious injury or even death may result from insufficient attention to or incorrect compliance with the related points.



CAUTION:

Indicates that personal injury or mechanical damage may result from insufficient attention to or incorrect compliance with the related points.

Symbols

The  symbol indicates that the related section includes safety warnings. Specific points of attention are indicated inside the symbol.



[General warning]



[Warning of high temperature]

The  symbol indicates that the related section includes information on prohibited actions. Specifics of the prohibited action are indicated inside the symbol.



[Warning of prohibited action]



[Disassembly prohibited]

The  symbol indicates that the related section includes information on actions which must be performed. Specifics of the required action are indicated inside the symbol.



[Alert of required action]



[Remove the power plug from the outlet]



[Always connect the machine to an outlet with a ground connection]



NOTE

An original which resembles a bank note closely may not be copied properly in some rare cases because this machine is equipped with a counterfeiting prevention function.

Environment

The service environmental conditions are as follows:

Temperature	10 to 32.5°C/50 to 90.5°F But humidity should be 70% or less when temperature is 90.5 °F (32.5 °C).
Humidity	10 to 80% But temperature should be 86 °F (30 °C) or less when humidity is 80%.

Avoid the following locations when selecting a site for the machine.

- Avoid locations near a window or with exposure to direct sunlight.
- Avoid locations with vibrations.
- Avoid locations with drastic temperature fluctuations.
- Avoid locations with direct exposure to hot or cold air.
- Avoid poorly ventilated locations.

During copying, some ozone is released, but the amount does not cause any ill effect to one's health.

If, however, the machine is used over a long period of time in a poorly ventilated room or when making an extremely large number of copies, the smell may become unpleasant.

To maintain the appropriate environment for copy work, it is suggested that the room be properly ventilated.

Precautions for Use

Cautions when handling consumables



CAUTION

Do not attempt to incinerate parts which contain toner. Dangerous sparks may cause burns.

Keep parts which contain toner out of the reach of children.

If toner happens to spill from parts which contain toner, avoid inhalation and ingestion, as well as contact with your eyes and skin.

- If you do happen to inhale toner, move to a place with fresh air and gargle thoroughly with a large amount of water. If coughing develops, contact a physician.
- If you do happen to ingest toner, rinse your mouth with water and drink 1 or 2 cups of water to dilute the contents of your stomach. If necessary, contact a physician.
- If you do happen to get toner in your eyes, flush them thoroughly with water. If there is any remaining tenderness, contact a physician.
- If toner does happen to get on your skin, wash with soap and water.

Do not attempt to force open or destroy parts which contain toner.

Other precautions

Return the exhausted toner container to your dealer or service representative. The collected toner container will be recycled or disposed in accordance with the relevant regulations.

Store the machine while avoiding exposure to direct sunlight.

Store the machine in a place where the temperature stays below 40 °C while avoiding sharp changes of temperature and humidity.

If the machine will not be used for an extended period of time, remove the paper from the cassette and the Multipurpose (MP) Tray, return it to its original package and reseal it.

SAFETY OF LASER BEAM (USA)

Safety of laser beam

This machine has been certified by the manufacturer to Class 1 level under the radiation performance standards established by the U.S.DHHS (Department of Health and Human Services) in 1968. This indicates that the product is safe to use during normal operation and maintenance. The laser optical system, enclosed in a protective housing and sealed within the external covers, never permits the laser beam to escape.

The CDRH Act

A laser-product-related act was implemented on Aug. 2, 1976, by the Center for Devices and Radiological Health (CDRH) of the U.S. Food and Drug Administration (FDA). This act prohibits the sale of laser products in the U.S. without certification, and applies to laser products manufactured after Aug. 1, 1976. The label shown below indicates compliance with the CDRH regulations and must be attached to laser products marketed in the United States.

The position of the rating label is show below.

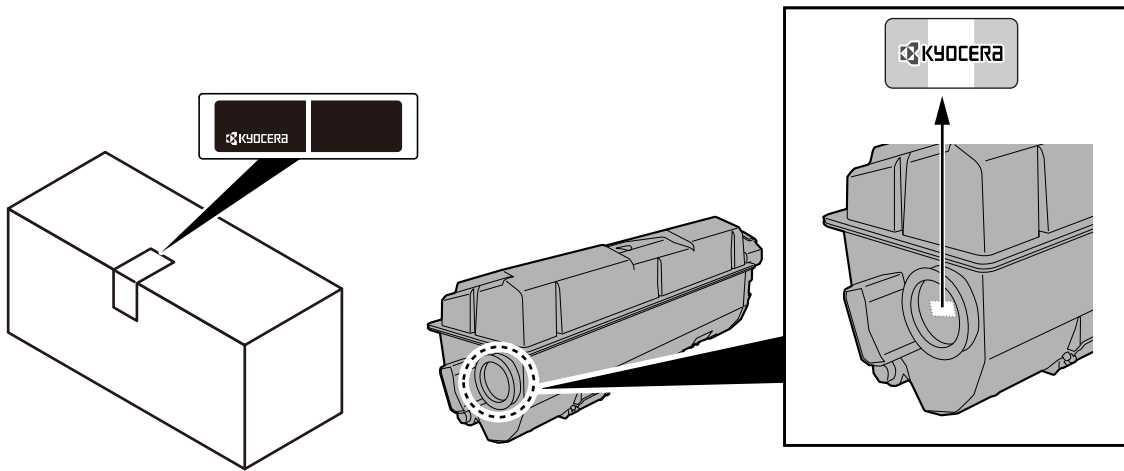

Optical unit

When checking the optical unit, avoid direct exposure to the laser beam, which is invisible. Shown at below is the label located on the cover of the optical unit.

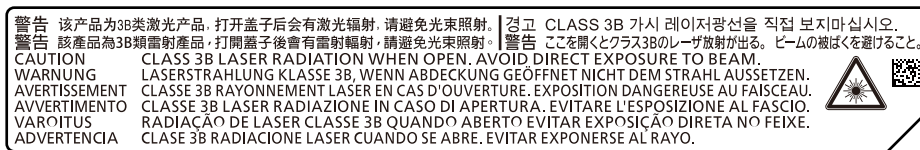

Maintenance

For safety of the service personnel, follow the maintenance instructions in the other section of this manual.

Safety Instructions Regarding the Disconnection of Power

Caution: The power plug is the main isolation device! Other switches on the equipment are only functional switches and are not suitable for isolating the equipment from the power source.

Attention: Le débranchement de la fiche secteur est le seul moyen de mettre l'appareil hors tension. Les interrupteurs sur l'appareil ne sont que des interrupteurs de fonctionnement: ils ne mettent pas l'appareil hors tension.

Compliance and Conformity

We hereby declare that this product complies with Directive 2014/53/EU.

The full text of the EU declaration of conformity is available at the following internet address:

<https://www.kyoceradocumentsolutions.eu/index/service/dlc.html>

Software Ver.	Frequency band in which the radio equipment operates:	Maximum radio-frequency power transmitted in the frequency and in which the radio equipment operates:
1.0	2.4GHz	100 mW
1.0	5GHz	50 mW - 1W

These limits are designed to provide reasonable protection against harmful interference in a residential installation. This equipment generates, uses and can radiate radio frequency energy and, if not installed and used in accordance with the instructions, may cause harmful interference to radio communications. However, there is no guarantee that interference will not occur in a particular installation. If this equipment does cause harmful interference to radio or television reception, which can be determined by turning the equipment off and on, the user is encouraged to try to correct the interference by one or more of the following measures:

- Reorient or relocate the receiving antenna.
- Increase the separation between the equipment and receiver.
- Connect the equipment into an outlet on a circuit different from that to which the receiver is connected.
- Consult the dealer or an experienced radio/TV technician for help.
- The use of a non-shielded interface cable with the referenced device is prohibited.

This device complies with Part 15 of FCC Rules.

Operation is subject to the following two conditions; (1) this device may not cause harmful interference, and (2) this device must accept any interference received, including interference that may cause undesired operation.

IMPORTANT NOTE:

Radiation Exposure Statement:

This equipment complies with FCC radiation exposure limits set forth for an uncontrolled environment. This equipment should be installed and operated with minimum distance 20cm between the radiator & your body.

Industry Canada statement:

This device contains licence-exempt transmitter(s) / receiver(s) that complies with Innovation, Science and Economic Development Canada's licence-exempt RSS (s). Operation is subject to the following two conditions:

- 1 This device may not cause interference.
- 2 This device must accept any interference, including interference that may cause undesired operation of the device.

The antenna(s) used for this transmitter must be installed to provide a separation distance of at least 20 cm from all persons and must not be co-located or operating in conjunction with any other transmitter.

Industry Canada ICES-003 Compliance Label: CAN ICES-3B/NMB-3B

* The above statements are valid only in the United States of America and Canada.

NOTE — Use shielded interface cables.

Caution:

The device for operation in the band 5150-5250 MHz is only for indoor use to reduce the potential for harmful interference to co-channel mobile satellite systems;

Operations in the 5.25-5.35GHz band are restricted to indoor usage only.

Radiation Exposure Statement:

This equipment complies with Canada radiation exposure limits set forth for an uncontrolled environment. This equipment should be installed and operated with minimum distance 20cm between the radiator & your body. * These above statements are valid in the United States of America, Canada.

Other precautions (for users in California, the United States)

Perchlorate Material - special handling may apply. See www.dtsc.ca.gov/hazardouswaste/perchlorate.

Warranty (the United States and Canada)

ECOSYS MA4000wifx / MA4000wfx / MA4000fx / MA4000x COLOR MULTIFUNCTIONAL PRODUCT LIMITED WARRANTY

KYOCERA Document Solutions America, Inc. and KYOCERA Document Solutions Canada, Ltd. (both referred to as "KYOCERA") warrant the Customer's new color Multifunctional Product (referred to as "MFP"), and the new accessories installed with the initial installation of the MFP, against any defects in material and workmanship for a period of one year, or 100,000 copies/prints from date of installation, whichever first occurs. In the event the MFP or an accessory is found to be defective within the warranty period, KYOCERA's only obligation and the Customer's exclusive remedy shall be replacement of any defective parts. KYOCERA shall have no obligation to furnish labor.

This warranty is valid only for the original retail purchaser (referred to as the "Customer") of a new KYOCERA MFP in the United States of America or Canada, based upon the country of purchase.

In order to obtain performance of this warranty, the Customer must immediately notify the Authorized KYOCERA Dealer from whom the product was purchased. If the KYOCERA Dealer is not able to provide service, write to KYOCERA at the address below for the name and address of the Authorized KYOCERA Dealer in your area, or check KYOCERA's website at <https://www.kyoceradocumentsolutions.com> for KYOCERA Document Solutions America, Inc. or <https://www.kyoceradocumentsolutions.ca> for KYOCERA Document Solutions Canada, Ltd.

This warranty does not cover MFPs or accessories which: (a) have become damaged due to operator negligence, misuse, accidents, improper storage or unusual physical or electrical stress, (b) have used parts or supplies which are not genuine KYOCERA brand parts or supplies, (c) have been installed or serviced by a technician not employed by KYOCERA or an Authorized KYOCERA Dealer, or (d) have had the serial number modified, altered, or removed.

This warranty gives the Customer specific legal rights. The Customer may also have other rights, which vary from state to state, or province to province. Neither the seller, nor any other person, is authorized to extend the time period or expand this warranty on behalf of KYOCERA.

THIS WARRANTY IS MADE IN LIEU OF ALL OTHER WARRANTIES AND CONDITIONS, EXPRESS OR IMPLIED, AND KYOCERA SPECIFICALLY DISCLAIMS ANY IMPLIED WARRANTY OR CONDITION OF MERCHANTABILITY OR FITNESS FOR A PARTICULAR PURPOSE. THIS WARRANTY SHALL NOT EXTEND TO, AND KYOCERA SHALL NOT BE LIABLE FOR, ANY INCIDENTAL OR CONSEQUENTIAL DAMAGES WHICH MAY ARISE OUT OF THE USE OF, OR INABILITY TO USE, THE MFP.

KYOCERA Document Solutions America, Inc.
225 Sand Road, P.O. Box 40008
Fairfield, New Jersey 07004-0008, USA

KYOCERA Document Solutions Canada, Ltd.
6120 Kestrel Rd., Mississauga, ON L5T 1S8,
Canada

Legal Restriction on Copying/Scanning

It may be prohibited to copy/scan copyrighted material without permission of the copyright owner.

Copying/Scanning the following items is prohibited and may be penalized by law. It may not be limited to these items. Do not knowingly copy/scan the items that are not to be copied/scanned.

- Paper money
- Bank note
- Securities
- Stamp
- Passport
- Certificate

Local laws and regulations may prohibit or restrict copying/scanning of other items not mentioned above.

Wireless Connection

For Mexico

IFT #: RCPKYIB21-1139

La operación de este equipo está sujeta a las siguientes dos condiciones:

- 1 es posible que este equipo o dispositivo no cause interferencia perjudicial y
- 2 este equipo o dispositivo debe aceptar cualquier interferencia, incluyendo la que pueda causar su operación no deseada.

For Brazil



18780-20-09076

Para maiores informações, consulte o site da ANATEL <http://www.anatel.gov.br>

Este equipamento não tem direito à proteção contra interferência prejudicial e não pode causar interferência em sistemas devidamente autorizados.

For Paraguay

NR: 2021-01-I-0031



For Argentina

CONTIENE



C-26005

Security Precautions when Using Wireless LAN (If equipped)

Wireless LAN allows information to be exchanged between wireless access points instead of using a network cable, which offers the advantage that a WLAN connection can be established freely within an area in which radio waves can be transmitted.

On the other hand, the following problems may occur if security settings are not configured, because radio waves can pass through obstacles (including walls) and reach everywhere within a certain area.

Secretly Viewing Communication Contents

A third person with malicious objectives may intentionally monitor radio waves and gain unauthorized access to the following communication contents.

- Personal information including ID, passwords, and credit card numbers
- Contents of email messages

Illegal Intrusion

A third party with malicious intent may gain unauthorized access to personal or company networks and conduct the following illegal actions.

- Extracting personal and confidential information (information leak)
- Entering into communication while impersonating a specific person and distributing unauthorized information (spoofing)
- Modifying and retransmitting intercepted communications (falsification)
- Transmitting computer viruses and destroying data and systems (destruction)

Wireless LAN cards and wireless access points contain built-in security mechanisms to address these problems and to reduce the possibility of these problems occurring by configuring the security settings of wireless LAN products when the product is used.

We recommend that customers take responsibility and use their judgment when configuring the security settings and that they ensure that they fully understand the problems that can occur when the product is used without configuring the security settings.

Limited Use of This Product

- Radio waves transmitted from this product may affect medical equipment. When using this product in a medical institution or in the vicinity of medical instruments, either use this product according to the instructions and precautions provided by the administrator of the institution or those provided on the medical instruments.
- Radio waves transmitted from this product may affect automatic control equipment including automatic doors and fire alarms. When using this product in the vicinity of the automatic control equipment, use this product according to the instructions and precautions provided on the automatic control equipment.
- If this product is used in devices that are directly related to service including airplanes, trains, ships, and automobiles or this product is used in applications requiring high reliability and safety to function and in devices requiring accuracy including those used in disaster prevention and crime prevention and those used for various safety purposes, please use this product after considering the safety design of the entire system including adoption of a failsafe design and redundancy design for reliability and safety maintenance of the entire system. This product is not intended for use in applications requiring high reliability and safety including aerospace instruments, trunk communication equipment, nuclear power control equipment, and medical equipment; hence, the decision as to whether to use this product in these applications needs to be fully considered and determined.

Legal and Safety Information

Unauthorized reproduction (copying) of all or part of this document is prohibited, with the exception of copyright law exceptions.

Regarding Trade Names

- PRESCRIBE and ECOSYS are registered trademarks of Kyocera Corporation.
- KPDL is a trademark of Kyocera Corporation.
- Active Directory, Azure, Excel, Microsoft, Microsoft 365, Microsoft Edge, PowerPoint, Windows and Windows Server are registered trademarks or trademarks of Microsoft Corporation in the U.S.A. and/or other countries.
- PCL is a trademark of Hewlett-Packard Company.
- Adobe, Acrobat, PostScript and Reader are registered trademarks or trademarks of Adobe Inc. in the U.S.A. and/or other countries.
- Ethernet is a registered trademark of Fuji Xerox Co., Ltd.
- IBM and IBM PC/AT are trademarks of International Business Machines Corporation.
- AppleTalk, Bonjour, Mac, and Mac OS are trademarks of Apple Inc., registered in the U.S. and other countries.
- All European language fonts installed in this machine are used under licensing agreement with Monotype Imaging Inc.
- Monotype, Helvetica Palatino, Times, and UFST are trademarks of Monotype Imaging Inc., registered with the U.S. Patent and Trademark Office and may be registered in other countries or regions.
- Helvetica, Palatino and Times are registered trademarks of Linotype GmbH.
- ITC Avant Garde Gothic, ITC Bookman, ITC ZapfChancery and ITC Zapf Dingbats are trademarks of Monotype Imaging Inc., registered with the U.S. Patent and Trademark Office and may be registered in other countries or regions.
- ThinPrint is a trademark of Cortado AG in Germany and other countries.
- This product has UFST Font Stylizer and [™] MicroType [®] fonts licensed from Monotype Imaging Inc. installed in this machine.
- iPad, iPhone and iPod touch are trademarks of Apple Inc., registered in the U.S. and other countries.
- AirPrint and the AirPrint logo are trademarks of Apple Inc.
- iOS is a trademark or registered trademark of Cisco in the U.S. and other countries and is used under license by Apple Inc.
- Google is trademarks and/or registered trademarks of Google LLC.
- Mopria [™] is a registered trademark of Mopria [™] Alliance.
- Wi-Fi, Wi-Fi Direct and Wi-Fi Protected Setup are trademarks and/or registered trademarks of Wi-Fi Alliance.
- RealVNC, VNC and RFB are registered trademarks of RealVNC Ltd. in the U.S. and in other countries.

All other brands and product names are registered trademarks or trademarks of their respective companies. Neither [™] nor [®] will be specified in the main text.

Monotype Imaging License Agreement

- 1 Software shall mean the digitally encoded, machine readable, scalable outline data as encoded in a special format as well as the UFST Software.
- 2 You agree to accept a non-exclusive license to use the Software to reproduce and display weights, styles and versions of letters, numerals, characters and symbols (Typefaces) solely for your own customary business or personal purposes at the address stated on the registration card you return to Monotype Imaging. Monotype Imaging retains all rights, titles and interests to the Software and Typefaces and no rights are granted to you other than a License to use the Software on the terms expressly set forth in this Agreement.
- 3 To protect proprietary rights of Monotype Imaging, you agree to maintain the Software and other proprietary information concerning the Typefaces in strict confidence and to establish reasonable procedures regulating access to and use of the Software and Typefaces.
- 4 You agree not to duplicate or copy the Software or Typefaces, except that you may make one backup copy.
- 5 This License shall continue until the last use of the Software and Typefaces, unless sooner terminated. This License may be terminated by Monotype Imaging if you fail to comply with the terms of this License and such failure is not remedied within thirty (30) days after notice from Monotype Imaging. When this License expires or is terminated, you shall either return to Monotype Imaging or destroy all copies of the Software and Typefaces and documentation as requested.
- 6 You agree that you will not modify, alter, disassemble, decrypt, reverse engineer or decompile the Software.
- 7 Monotype Imaging warrants that for ninety (90) days after delivery, the Software will perform in accordance with Monotype Imaging-published specifications, and the diskette will be free from defects in material and workmanship. Monotype Imaging does not warrant that the Software is free from all bugs, errors and omissions.

The parties agree that all other warranties, expressed or implied, including warranties of fitness for a particular purpose and merchantability, are excluded.
- 8 Your exclusive remedy and the sole liability of Monotype Imaging in connection with the Software and Typefaces is repair or replacement of defective parts, upon their return to Monotype Imaging.

In no event will Monotype Imaging be liable for lost profits, lost data, or any other incidental or consequential damages, or any damages caused by abuse or misapplication of the Software and Typefaces.
- 9 Massachusetts U.S.A. law governs this Agreement.
- 10 You shall not sublicense, sell, lease, or otherwise transfer the Software and/or Typefaces without the prior written consent of Monotype Imaging.
- 11 Use, duplication or disclosure by the Government is subject to restrictions as set forth in the Rights in Technical Data and Computer Software clause at FAR 252-227-7013, subdivision (b)(3)(ii) or subparagraph (c)(1)(ii), as appropriate.

Further use, duplication or disclosure is subject to restrictions applicable to restricted rights software as set forth in FAR 52.227-19 (c)(2).
- 12 You acknowledge that you have read this Agreement, understand it, and agree to be bound by its terms and conditions. Neither party shall be bound by any statement or representation not contained in this Agreement. No change in this Agreement is effective unless written and signed by properly authorized representatives of each party.

OpenSSL License

For the Open Source Software license, go into the following URL and select Country > Product Name > OS > Language and then, refer to the "OSS_Notice" from the manual tab in the Download.

<https://kyocera.info/>

Energy Saving Control Function

To reduce power consumption when idle, the device comes equipped with a power management function that automatically shifts to "Sleep" to minimize power consumption after a certain period of time has passed since the device was last used.

➔ [Sleep \(page 81\)](#)

Automatic 2-Sided Print Function

This device includes 2-sided printing as a standard function. For example, by printing two 1-sided originals onto a single sheet of paper as a 2-sided print, it is possible to lower the amount of paper used.

➔ [DuplexDuplex \(page 314\)](#)

Printing in duplex mode reduces paper consumption and contributes to the conservation of forest resources. Duplex mode also reduces the amount of paper that must be purchased, and thereby reduces cost. It is recommended that machines capable of duplex printing be set to use duplex mode by default.

Resource Saving - Paper

For the preservation and sustainable use of forest resources, it is recommended that recycled as well as virgin paper certified under environmental stewardship initiatives or carrying recognized ecolabels, which meet EN 12281:2002* or an equivalent quality standard, be used.

This machine also supports printing on 64 g/m² paper. Using such paper containing less raw materials can lead to further saving of forest resources.

* : EN12281:2002 "Printing and business paper - Requirements for copy paper for dry toner imaging processes"

Contact your dealer or service representative for recommended paper types.

Environmental benefits of "Power Management"

To reduce power consumption when idle, this machine is equipped with a power management function that automatically activates energy-saving mode when the machine is idle for a certain period of time.

Although it takes the machine a slight amount of time to return to READY mode when in energy-saving mode, a significant reduction in energy consumption is possible. It is recommended that the machine be used with the activation time for energy-saving mode set to the default setting.

ENERGY STAR Program



We participate in the ENERGY STAR® Program. We provide the products that comply with ENERGY STAR standards to the market.

ENERGY STAR is an energy efficiency program with the goal of developing and promoting the use of products with high energy efficiency in order to help prevent global warming. By purchasing the products that comply with ENERGY STAR, customers can help reduce emissions of greenhouse gases during product use and cut energy-related costs.

Precautions for security when using wireless LAN

Wireless LAN has the advantage that it allows free LAN connections within the range of radio waves because it uses radio waves to exchange information between a PC and a wireless access point, not using a network cable.

On the other hand, radio waves can reach any location though obstacles (such as walls) within a certain range, so if you do not perform security setting, the following problems may occur.

Eavesdropping of communications

A malicious third party may intentionally intercept radio waves and eavesdrops the following types of communications.

- Personal information such as an ID, password, or credit card number
- Contents of emails

Illegal access

A malicious third party may gain access to your personal or company network without your permission and perform the following illegal actions.

- Extract personal or confidential information (information leakage)
- Impersonate a certain person and spread false information (impersonation)
- Change and transmit the contents of intercepted communications (alteration)
- Spread computer viruses to destroy data and systems (destruction)

Wireless LAN cards and wireless access points originally have security mechanisms to deal with these problems, so by configuring the security settings of your wireless LAN products and using them, the chances of these problems occurring can be reduced.

We recommend that you configure security settings and use the product at your own discretion and responsibility, after gaining a thorough understanding of the problems that may occur if the product is used without security settings.

2 Installing and Setting up the Machine

Part Names (Machine Exterior)

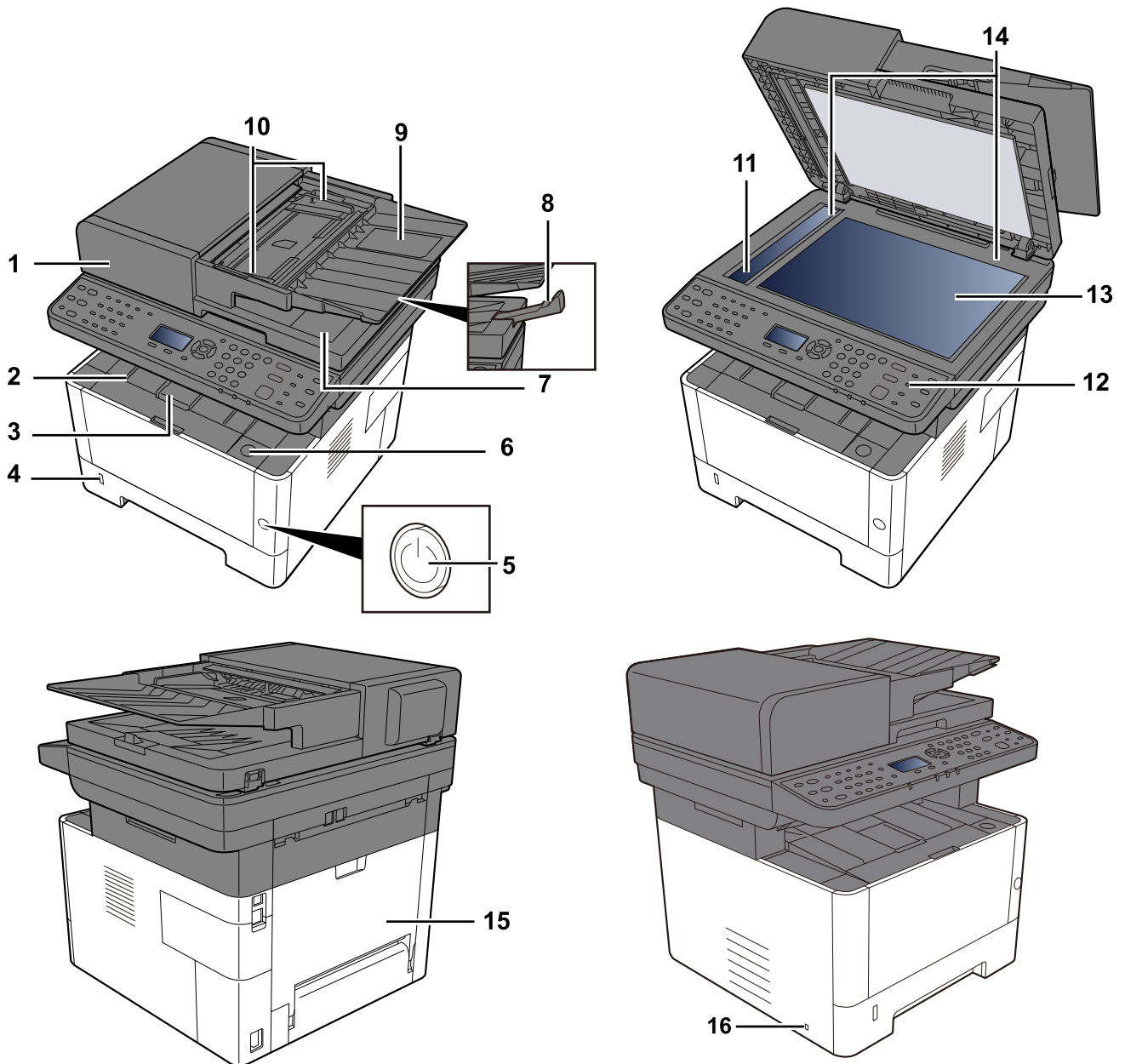

- 1 Document processor
- 2 Inner tray
- 3 Eject stopper
- 4 Cassette 1
- 5 Main switch
- 6 Front cover open button
- 7 Original eject table
- 8 Original stopper
- 9 Original tray
- 10 Original width guide
- 11 Slit glass
- 12 Operation panel
- 13 Original glass

14 Original size indicator plate

15 Rear cover

16 Anti-theft slot

Part Names (Connectors/Interior)

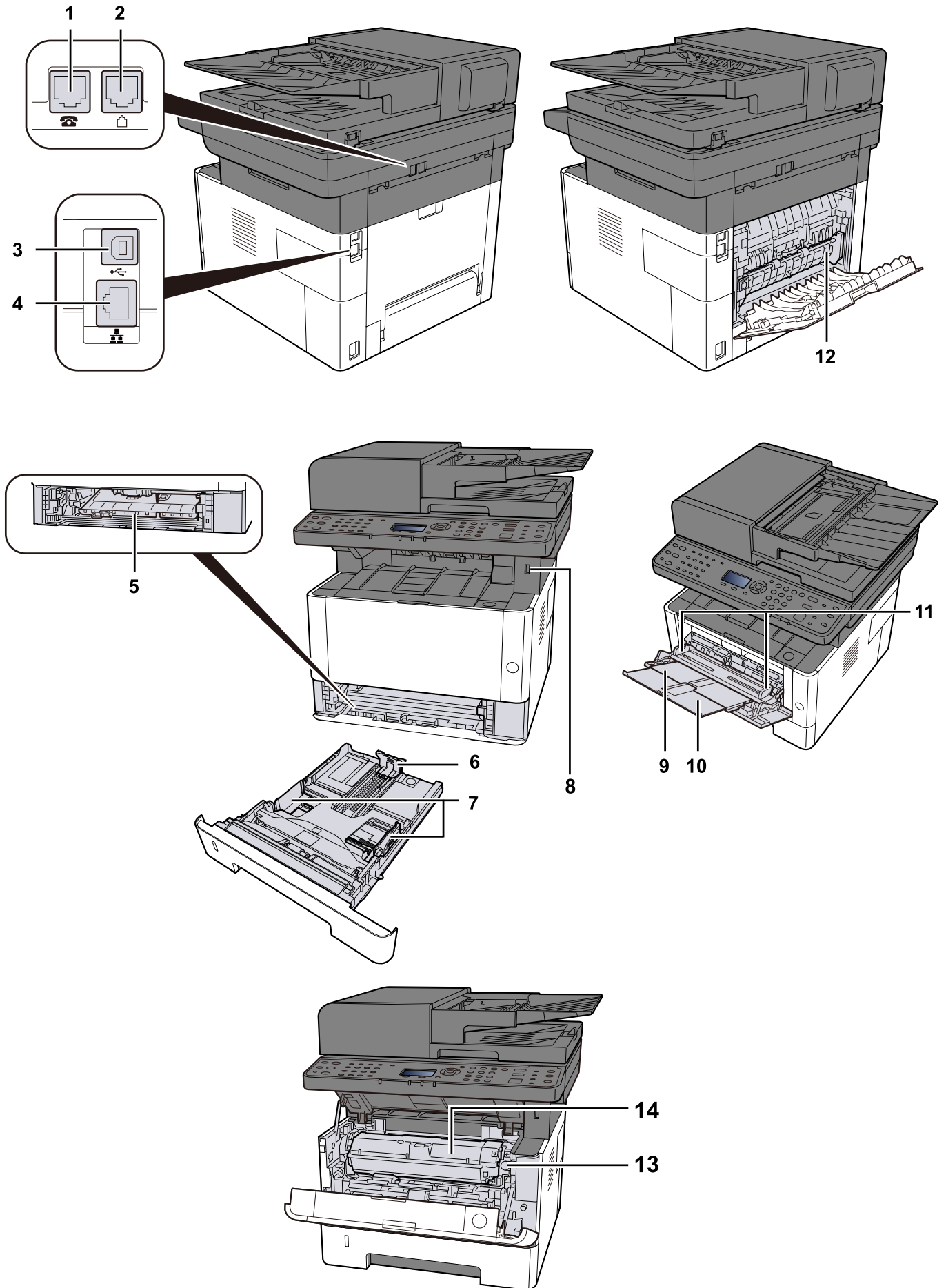

- 1 TEL connector
- 2 LINE connector
- 3 USB interface connector
- 4 Network interface connector
- 5 Conveying cover
- 6 Paper length guide
- 7 Paper width guide
- 8 USB Memory slot
- 9 MP Tray
- 10 MP support tray
- 11 Paper guide
- 12 Fuser cover
- 13 Toner container Release Button
- 14 Toner container

Part Names (With Optional Equipments Attached)

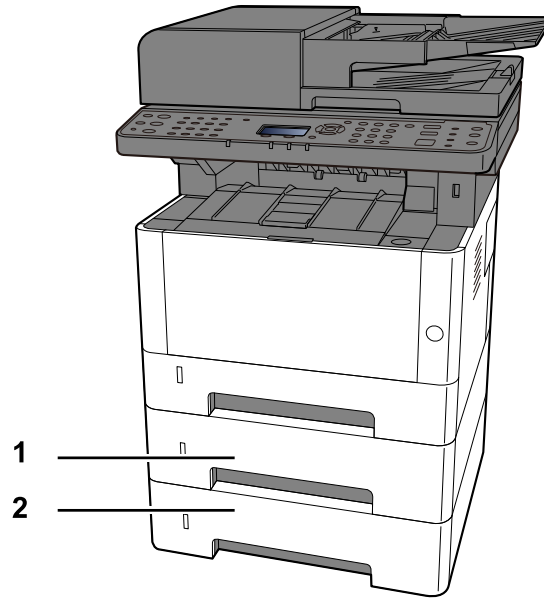

- 1 Cassette 2
- 2 Cassette 3

How to hold the device

When carrying the device, be careful where you hold it.

 **IMPORTANT**

To carry the machine, hold the scanner unit as shown in the illustration. Do not hold the control panel of the main unit as this may cause damage.

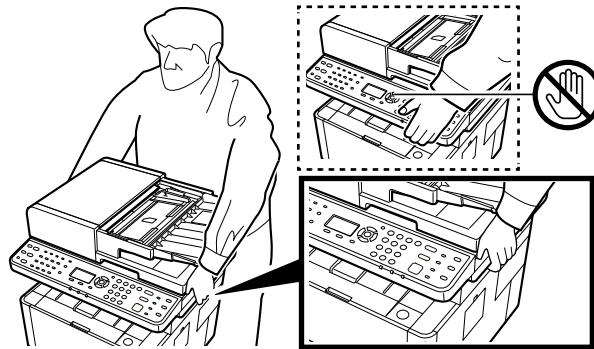

Connecting the Machine and Other Devices

Prepare the cables necessary to suit the environment and purpose of the machine use.

When Connecting the Machine to the PC via USB

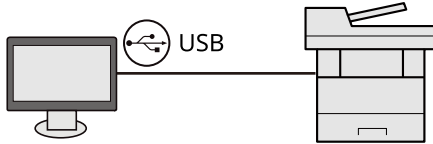

When Connecting the Machine to the PC or Tablet by network cable, Wi-Fi, or Wi-Fi direct

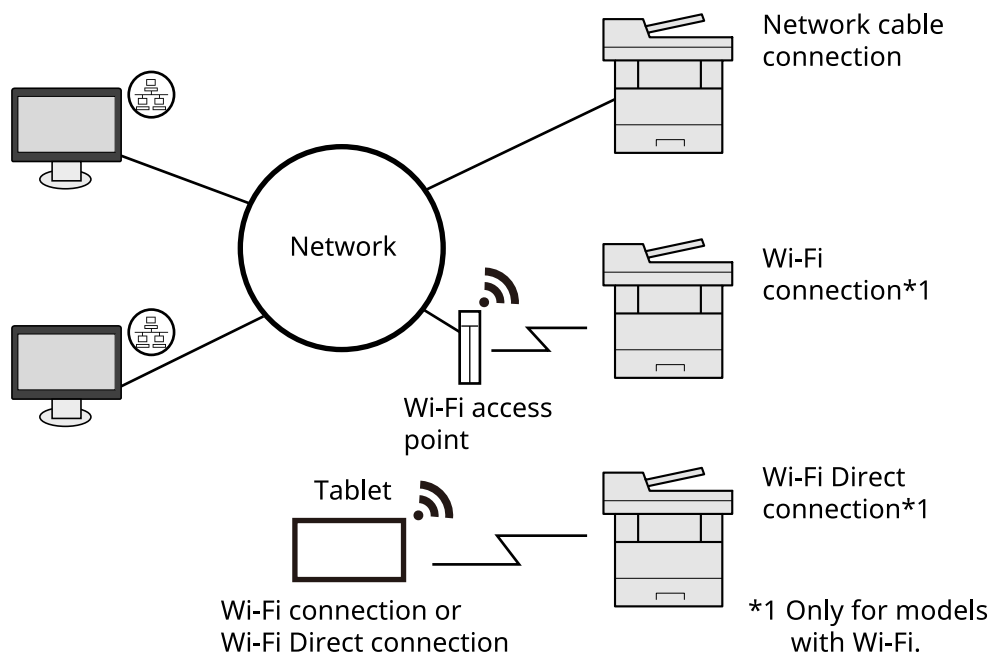

NOTE

If you are using wireless LAN, refer to the following.

➔ [Configuring the Wireless Network \(page 71\)](#)

Cables that Can Be Used

When a network cable is used to connect the machine

Function	Necessary Cable
Printer/Scanner/Network FAX*1	LAN cable (10BASE-T, 100BASE-TX, 1000BASE-T)

When a USB cable is used to connect the machine

Function	Necessary Cable
Printer/Scanner (TWAIN/WIA)	USB 2.0 compatible cable (Hi-Speed USB compliant, max. 5.0 m, shielded)

*1 The fax function can be used on products equipped with fax capability. For more information on Network FAX, refer to the following:

➔ **FAX Operation Guide**

 **IMPORTANT**

Using a cable other than a USB 2.0 compatible cable may cause failure.

Connecting Cables

Connecting LAN Cable

✔ **IMPORTANT**

If the power is on, turn the power switch off.

➔ [Power off \(page 56\)](#)

1 Connect the cable to the machine.

- 1 Connect the LAN cable to the network interface connector.

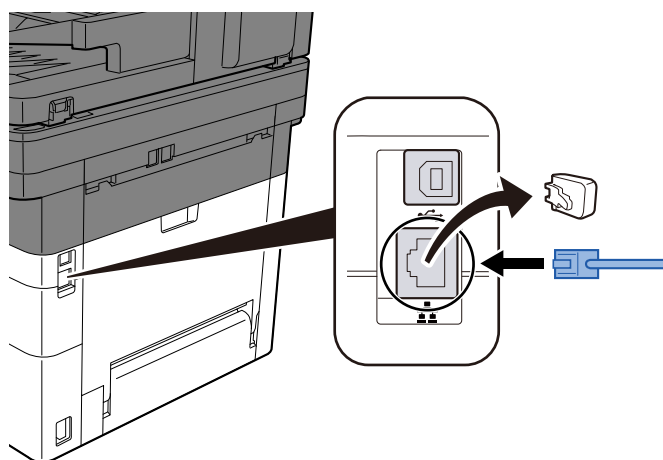

- 2 Connect the other end of the cable to the hub.

2 Power on the machine and configure the network.

➔ [Network Setup \(page 69\)](#)

Connecting USB Cable

✓ **IMPORTANT**

If the power is on, turn the power switch off.

Power off

1 Connect the cable to the machine.

- 1 Connect the USB cable to the USB interface connector.

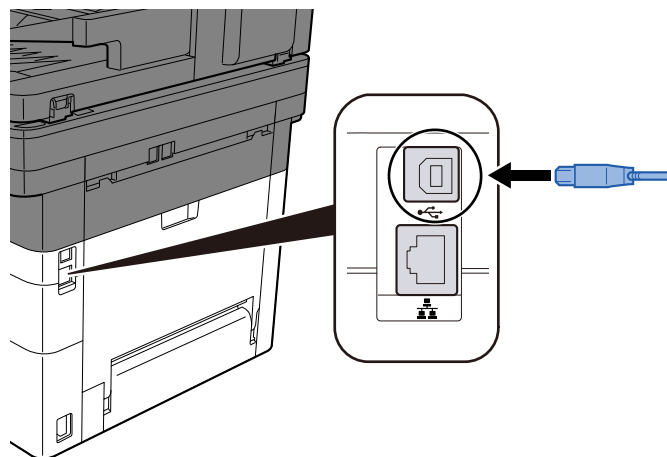

- 2 Connect the other end of the cable to the PC.

2 Power on the machine.

Connecting the Power Cable

1 Connect the cable to the machine.

Connect one end of the supplied power cable to the machine and the other end to a power outlet.

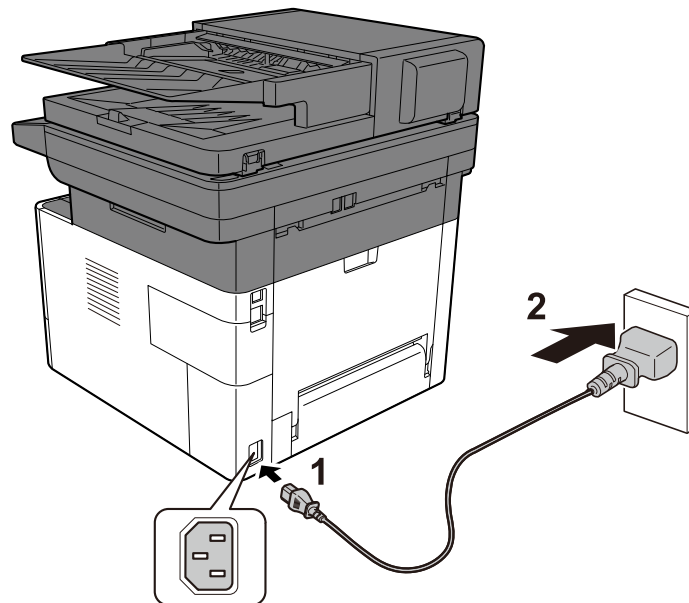

 **IMPORTANT**

Only use the power cable that comes with the machine.

Power On/Off

Power on

- 1 Turn the power switch on.

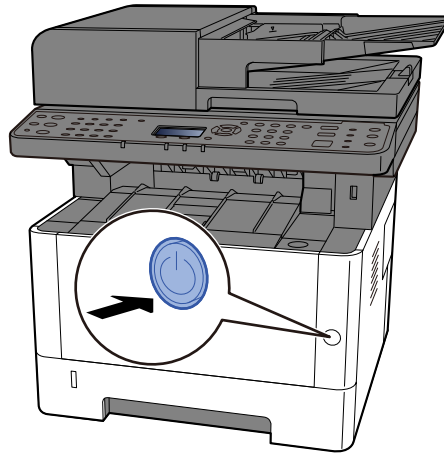

 **IMPORTANT**

Wait more than 5 seconds, and then turn on the power switch.

Power off

1 Turn the power switch off.

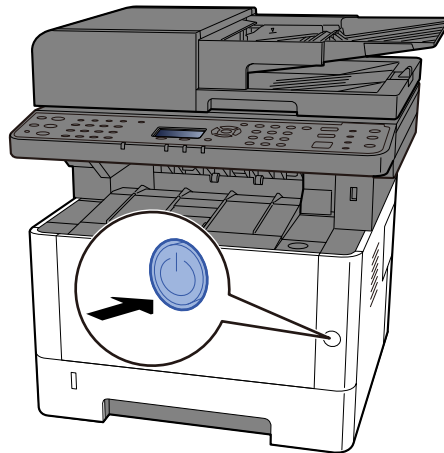

The confirmation message for power supply off is displayed.

It takes approximately 3 minutes for power off.

CAUTION

If this machine will be left unused for an extended period (e.g. overnight), turn it off at the power switch. If the machine will not be used for an even longer period of time (e.g. vacation), remove the power plug from the outlet as a safety precaution.

IMPORTANT

- If using the products equipped with the fax function, note that turning the machine off at the power switch disables fax transmission and reception.
 - Remove paper from the cassettes and seal it in the paper storage bag to protect it from humidity.
-

Using the Operation Panel

Operation Panel Keys

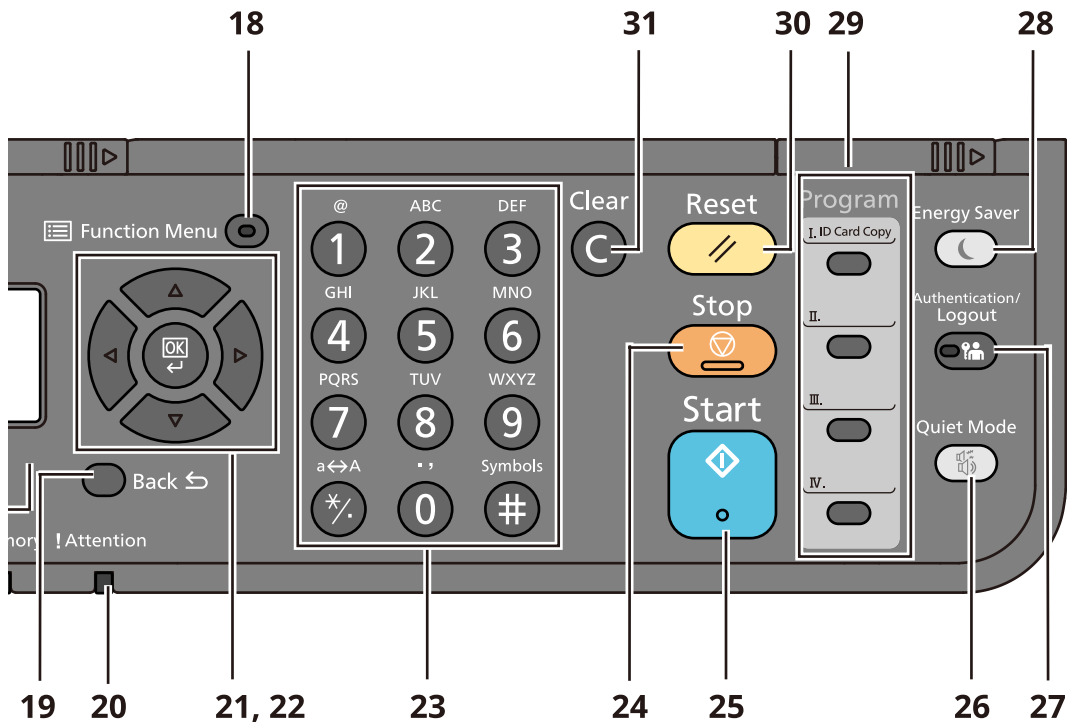
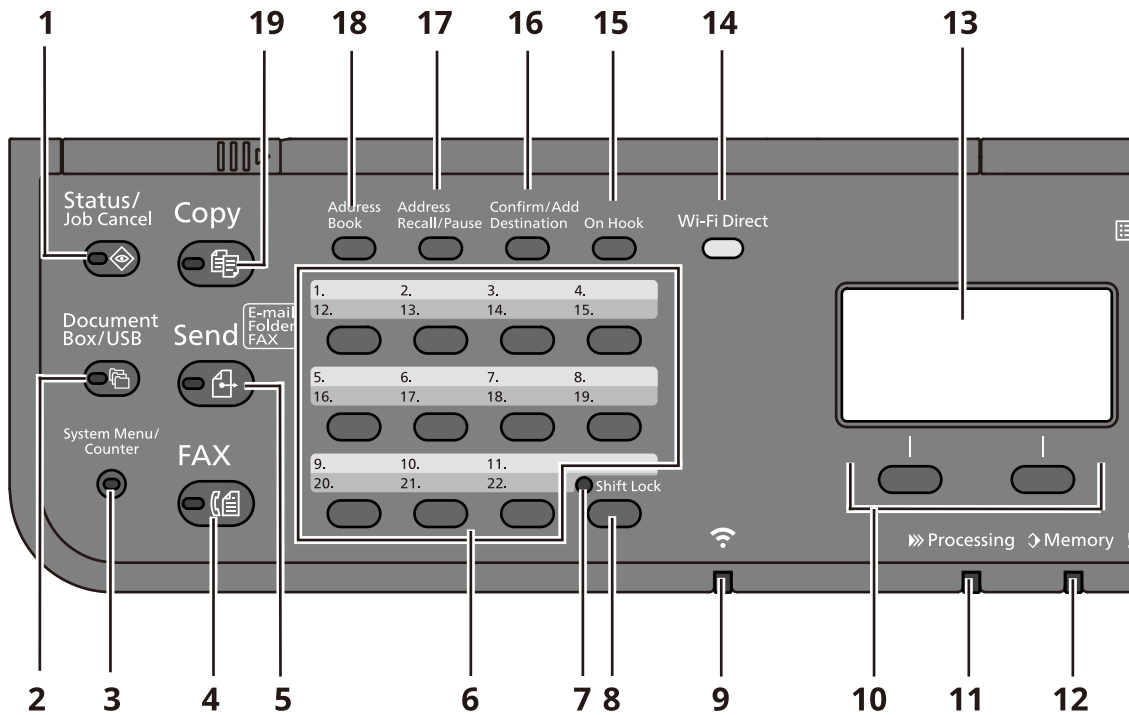

- 1 [Status/Job Cancel] key
Displays the Status/Job Cancel screen.
- 2 [Document Box/USB] key
Displays the Document Box/USB screen.
- 3 [System Menu/Counter] key
Display the System Menu/Counter screen.

4 [FAX] key

Displays the Fax screen.

- (Fax model) only

5 [Send] key

The Send Base screen is displayed. You can set the machine up so that the address book screen is displayed.

6 One touch keys

Calls destinations that have been registered on the One Touch Keys.

7 [Shift lock] indicator

Lights up when the One Touch Key number is between 12 to 22.

8 [Shift lock] key

Switches between One Touch Key numbers.

9 [Wi-fi] indicator

Lights up when Wi-Fi is connected.

- (Wi-Fi model) only

10 Selection keys

Select the menu that displayed under the LDC panel.

11 [Processing] indicator

Flashes while printing or sending/receiving.

12 [Memory] indicator

Flashes while accessing the device's memory or fax memory.

13 LDC panel

Displays setting items, the status of the device, and error messages.

14 [Wi-fi Direct] key

Configure Wi-Fi Direct settings and display information required for connection and connection status.

- (Wi-Fi model) only

15 [On Hook] key

Switch between on-hook/off-hook for the phone line.

- (Fax model) only

16 [Confirm/Add stination] key

Used to confirm or add destinations.

17 [Address Recall/Pause] key

Calls the destination for the previous job. Also used to enter a pause (-) when entering a fax number.

18 [Address Book] key

Displays the Address Book screen.

19 [Copy] key

Displays the Copy screen.

20 [Back] key

Return to the previous screen.

21 [Attention] indicator

Lights or blinks when an error occurs and a job is stopped.

22 [Arrow] key

Increase/decrease the numerical value at the LCD panel, or select the menu. Also used to move the cursor during character input.

23 [OK] key

Confirm the function or the menu inputted, or the numerical value.

24 Numeric keys

Input the number or the symbol.

25 [Stop] key

Cancel or pause the job in progress

26 [Start] key

Start copying and scanning operations and processing for setting operations.

27 [Quiet Mode] key

The operating sound of the machine can be suppressed.

28 [Authentication/Logout] key

Authentication of the switching users and finish operation of each user (Log out).

29 [Energy Saver] key

Make this main unit into the Sleep Mode condition. Recovers from the Sleep Mode in case of the sleep mode condition.

30 Program keys

Register and call programs.

31 [Reset] key

Return settings to the default condition.

32 [Clear] key

Delete the value or the letter inputted.

33 [Function Menu] key

Display the Function Settings screen.

Using the Operation Panel

Here, using the setting menu as an example, operation of the operation panel will be explained.
 Selecting the [System Menu/Counter] key will display the setting menu.

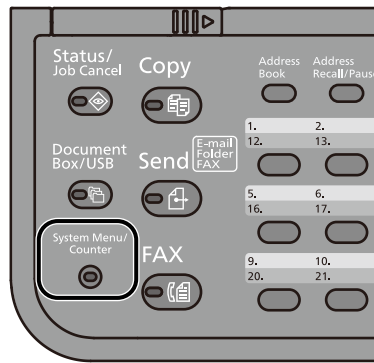

Displays the direction of arrow keys that are useable on the displayed screen.

When you select the [▲] or [▼] key, the selected item moves by one line.

When you select the [◀] or [▶] key, the selected item moves to page increments.

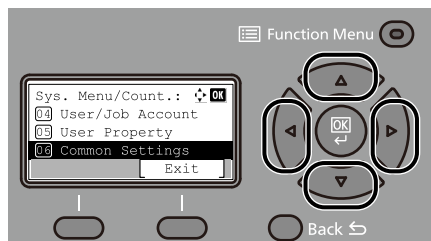

When [OK] is displayed, selecting the [OK] key will confirm the selection.

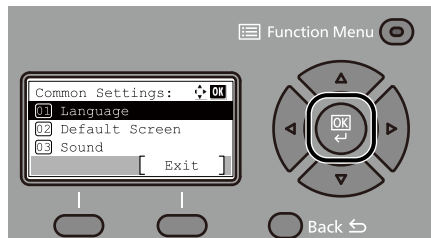

Selecting the [Back] key will return to the previous level in the menu.

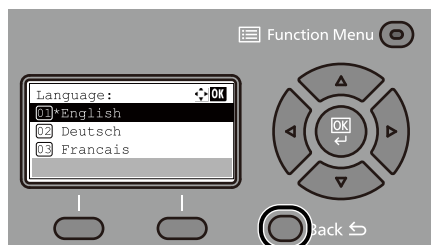

* is displayed at the beginning of the selected item.

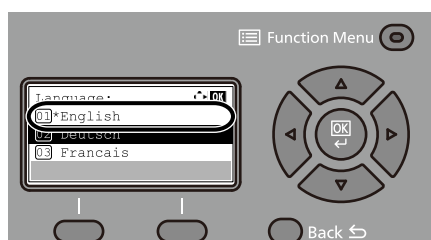

When [Exit] is displayed, selecting [Exit] will return to the normal screen from the Setting Menu screen.

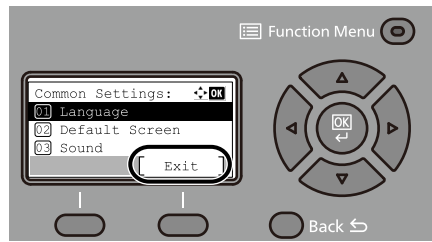

Help Screen

If you have difficulty operating the machine, you can check how to operate it using the touch panel.

When [Help] is displayed, select [Help] to display the Help screen. The Help screen shows the machine operation..

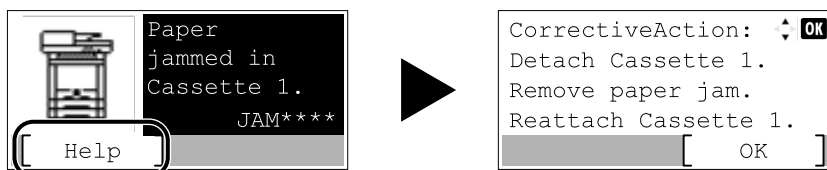

Login/Logout

Login

1 Enter the login user name.

- 1 If the login screen is displayed during operations, select a [Login User Name] and press the [OK] key.

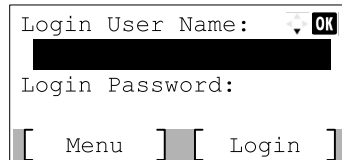

NOTE

If the user authentication method is set to [Netwk Authentic.], [Menu] is displayed. Selecting [Menu] and then [Login Type] allows either [Local Authentic.] or [Netwk Authentic.] to be selected as the authentication destination. Selecting [Menu] and then [Domain] allows a registered domain to be selected.

- 2 Using the numeric keypad, enter [Login User Name] and select the [OK] key.

NOTE

If you do not know your login User Name, please contact your Administrator.

If [Select Character] is selected in the login operation settings, select the characters displayed on the screen and enter [Login User Name].

2 Enter the password.

- 1 Select [Login Password], and select the [OK] key.

3 Select [Login].

Log in by ID card

- 1** When IC card authentication is enabled and user management is set, "Use ID card to login." appears when the machine is used.
- 2** Hold the Login card over the IC card reader to log in.

 **IMPORTANT**

- Hold the IC card 10 mm or closer to the IC card reader to read the IC card.
 - Do not stack more than one IC card for reading.
-

 **NOTE**

If you have set [Additional Authentication] to [Use Password], enter your login password after authenticating with your IC card.

Refer to the following for the setting method.

➔ [Additional Authentication \(page 511\)](#)

Log in using a keyboard

If IC card authentication is enabled, you can log in without using an IC card by entering your login username and password.

NOTE

You can allow or prevent logins. Refer to the following for the setting method.

→ [Key Login \(page 510\)](#)

- 1** Select [Key Login] on the IC card login screen.
- 2** Enter the login username and select the [OK] key.
- 3** Select [Login Password] with the [▼] key.
- 4** Select the [OK] key.
- 5** Enter the login password and select the [OK] key.

Logout

1 Select the [Authentication/Logout] key.

You will return to the login user name/login password entry screen.

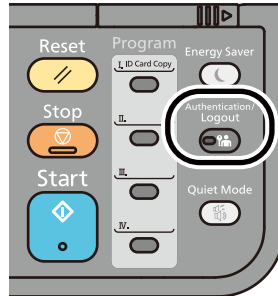

NOTE

Users are automatically logged out in the following circumstances:

- When the machine enters the sleep state.
 - When the auto panel reset function is activated.
-

Default Settings of the Machine

The default settings of the machine can be changed in [System Menu/Counter]. Before using this machine, configure such settings as date and time, network configuration, and energy saving functions as needed.

NOTE

For items that can be set with [System Menu/Counter], refer to the following:

➔ [System Menu \(page 365\)](#)

Setting Date and Time

Follow the steps below to set the local date and time at the place of installation. When you send an E-mail using the transmission function, the date and time as set here will be printed in the header of the E-mail message. Set the date, time and time difference from GMT of the region where the machine is used.

NOTE

- To make changes after this initial configuration, refer to the following:
➔ [\[Date/Time\] \(page 441\)](#)
 - The correct time can be periodically set by obtaining the time from the network time server.
➔ **Command Center RX User Guide**
-

1 Display the screen

[System Menu/Counter] key > [▲][▼] keys > [Common Settings] > [OK] key > [▲][▼] key > [Date Setting] > [OK] key

2 Configure the settings

Select and set [Date/Time] > [Date Format] > [Time Zone] in this order.

[Date/Time]

Set the date and time for the location where you use the machine.

Setting values: Year (2000-2035), Month (1-12), Day (1-31), Hour (0-23), Minute (0-59), Second (0-59)

[Date Format]

Select the display format of year, month, and date. The year is displayed in Western notation.

Value: [Month/Day/Year], [Day/Month/Year], [Year/Month/Day]

[Time Zone]

Set the time difference from GMT. Choose the nearest listed location from the list. If you select a region that utilizes summer time, configure settings for summer time.



NOTE

Use the [▲] or [▼] key to enter numbers.

When you select the [◀] or [▶] key, the input position moves to the left or right and is highlighted.

Network Setup

Configuring the Wired Network

The machine is equipped with network interface, which is compatible with network protocols such as TCP/IP (IPv4), TCP/IP (IPv6), NetBEUI, and IPSec. It enables network printing on the Windows, Mac, UNIX and other platforms. The configuration methods are as follows:

Configuration Method	Description
Configuring the Connection from the Operation Panel on This Machine	Perform individual settings from the system menu.
Configuring Connections on the Web Page	For the equipped network interface, the connection can be set by using Command Center RX. ➔ Command Center RX User Guide



NOTE

When you want to switch to the network interface other than Wired, select the desired setting on [Primary Network].

For other network settings, refer to the following:

➔ [\[Network Setting\] \(page 375\)](#)

TCP/IP (IPv4) setting



NOTE

If the user authentication screen appears, log in with a user who has the privilege to configure this setting. If you do not know your login user name or password, please contact your administrator.

1 Display the screen

[System Menu/Counter] key > [▲][▼] keys > [System/Network] > [OK] key > [▲][▼] keys > [Network Setting] > [OK] key > [▲][▼] keys > [Wired Netwk. Set] > [TCP/IP Settings] > [OK] key > [▲][▼] keys > [IPv4 Setting] > [OK] key



NOTE

- For Windows 11, select the Windows [Start] button → [All apps] → [Windows Tools] → [Control Panel] → [Devices and Printers], in that order.

2 Configure the settings

- When using DHCP server
 - [DHCP]: Configure the settings
- When setting the static IP address
 - [DHCP]: Off
 - [Auto-IP]: Off
 - [IP Address]: Enter the address.
 - [Subnet Mask]: Enter the subnet mask in decimal representation (0 to 255).
 - [Default Gateway]: Enter the address.

- When using the Auto-IP

Enter "0.0.0.0" in IP Address.

- When setting the DNS server

In the following cases, set the IP address of DNS (Domain Name System) server.

- When using the host name with [DHCP] setting set to [Off].
- When using the DNS server with IP address that is not assigned by DHCP automatically.

Select [Auto (DHCP)] or [Manual]. If you selected [Manual], enter the [Primary Server] and [Secondary Server].

IMPORTANT

After changing the setting, perform [Restart Network] with the following procedure, or turn the machine OFF and then ON.

➔ [\[Restart Network\] \(page 384\)](#)

Configuring the Wireless Network

When Wi-Fi settings are configured, it is possible to print or send in a wireless network (wireless LAN) environment.

The configuration methods are as follows:

Configuration Method	Description
Configuring the Connection from the Operation Panel on This Machine	Use Quick Setup Wizard when configuring the network in a wizard-style screen, without setting individually in System menu. ➔ [Wi-Fi Settings] (page 379)
Using the Wi-Fi Setup Tool	This is a tool that can be downloaded from Download Center (https://kyocera.info/). You can configure the connection according to the instructions provided by the wizard. ➔ Wired Connection with LAN Cable Using Wi-Fi Setup Tool (page 71)
Configuring Connections on the Web Page	➔ Command Center RX User Guide
	This is a tool that can be downloaded from Download Center (https://kyocera.info/) and from digital content distribution services. You can configure the connection according to the instructions provided by the wizard.

NOTE

When you want to switch to the network interface other than Wired, select the desired setting on [Primary Network].

➔ [\[Primary Network\] \(page 404\)](#)

Wired Connection with LAN Cable Using Wi-Fi Setup Tool

To send the Wi-Fi settings configured in the Wi-Fi Setup Tool to the machine, connect the computer or mobile device with the machine locally. To use a wired LAN cable directly connected to the machine, the Auto-IP (Link-local) address will be assigned to the machine and the computer. This machine applies Auto-IP as the default settings.

NOTE

Configure the settings on the operation panel if your computer supports WPS.

➔ [\[Wi-Fi Settings\] \(page 379\)](#)

1 Connect the machine with a computer.

- 1 Connect the machine with a computer via LAN cable when the machine is powered on.
 - 2 Turn on the computer.
- IP addresses (link local addresses) of the machine and computer are generated automatically.

2 Launch the Wi-Fi Setup Tool.

- 1 Launch your Web browser.
- 2 Enter "https://kyocera.info/" into the browser's address bar or location bar.



- 3 Enter and search the product name, and select this product from the candidate list.

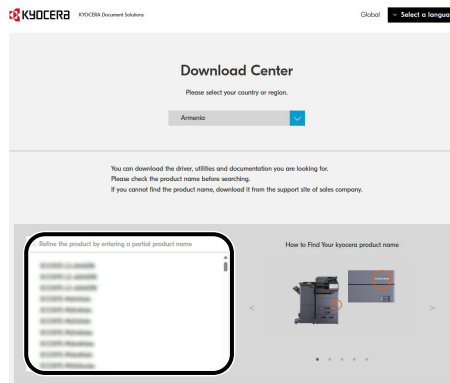

- 4 Change the selected operating system and its language setting as needed.

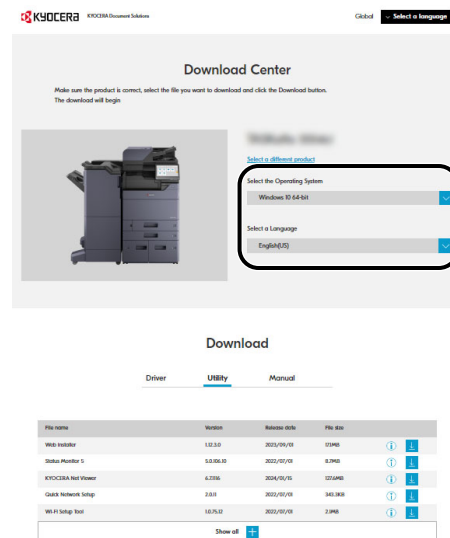

File name	Version	Release date	File size		
Web Indicator	1.02.00	2022/09/01	03MB		
Status Monitor 5	5.0.00.01	2022/07/01	8.2MB		
KYOCERA Net Viewer	6.2386	2024/05/01	127.0MB		
Quick Network Setup	2.011	2022/05/01	343.3KB		
Wi-Fi Setup Tool	1.02.012	2022/05/01	2.3MB		

- Utility tab >  of Wi-Fi Setup Tool.
The Wi-Fi Setup Tool will be downloaded.

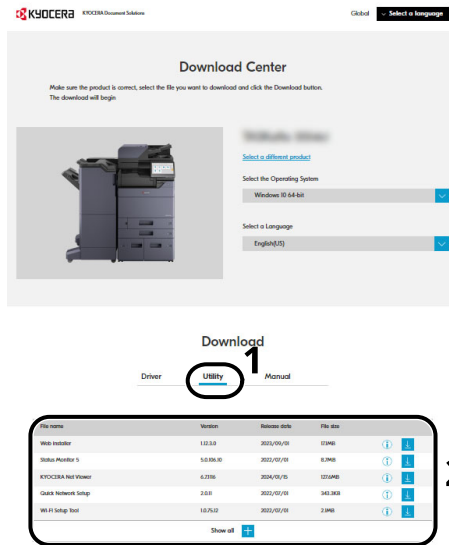

- Double-click the downloaded installer to launch.

 **NOTE**

- Installation on Windows must be done by a user logged on with administrator privileges.
- If the user account management window appears, click [Yes].

3 Configure the settings

- [Do not user WPS] > [Next] > [Next]
- [LAN Cable] > [Next] > [Next]
- [Quick Setup] > [Next]
The machine is detected.

 **NOTE**

- Only one machine can be searched using Wi-Fi Setup Tool. It may take times to search the machine.
- If the device is not detected, select [Detail Settings] > [Next]. You can specify an IP address or hostname as the detection method by selecting either [Express] or [Custom] from the detection methods of the machine.

- Select the machine > [Next]
- Select [Use device settings] from [Authentication mode] and enter [Login User Name] and [Login Password] > [Next]
Enter the administrator login user name and login password.
- Configure the communication settings and click [Next].

7 Change the settings of access point as necessary > [Next]

The network is configured.

Wireless LAN Connection by Wi-Fi Direct Using Wi-Fi Setup Tool

To send the Wi-Fi settings configured in the Wi-Fi Setup Tool to the machine, connect the computer or mobile device with the machine locally.

To use Wi-Fi Direct, confirm that the Wi-Fi Direct is enabled (Wi-Fi Direct is set to ON) and Restart Network from the operation panel, before your computer will be connected to this machine with Wi-Fi Direct.



NOTE

Configure the settings on the operation panel if your computer supports WPS.

→ [\[Wi-Fi Settings\] \(page 379\)](#)

1 Display the screen

[System Menu/Counter] key > [▲][▼] keys > [System/Network] > [Network Setting] > [OK] key > [▲][▼] keys > [Wi-Fi Direct Set] > [OK] key > [▲][▼] keys > [Wi-Fi Direct] > [OK] key

2 Configure the settings

[▲][▼] keys > [On] > [OK] key

3 Restart the network.

[System Menu/Counter] key > [▲][▼] keys > [System/Network] > [Network Setting] > [OK] key > [▲][▼] keys > [Restart Network] > [OK] key > [Yes]

4 Connect a computer or a mobile device with the machine.

→ [Setting Wi-Fi Direct \(page 78\)](#)

5 Launch the Wi-Fi Setup Tool.

- 1 Launch your Web browser.
- 2 Enter "https://kyocera.info/" into the browser's address bar or location bar.

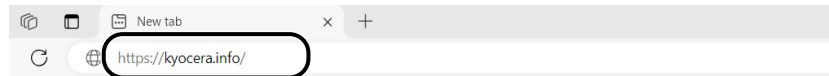

- 3 Enter and search the product name, and select this product from the candidate list.

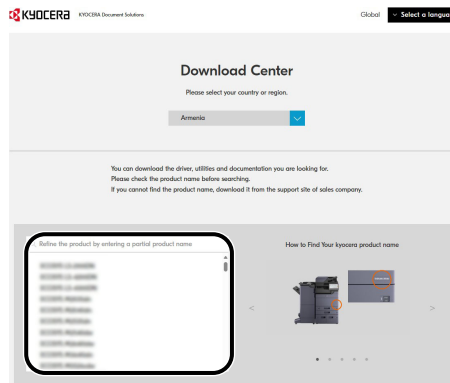

- 4 Change the selected operating system and its language setting as needed.

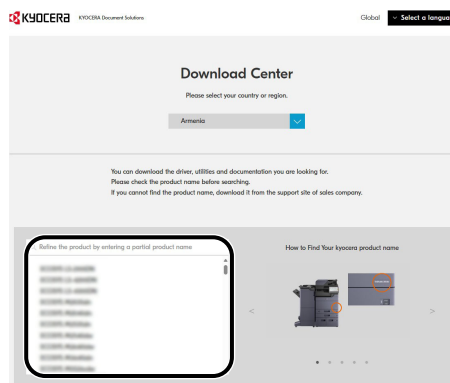

- 5 Click  of Wi-Fi Setup Tool.

The Wi-Fi Setup Tool will be downloaded.

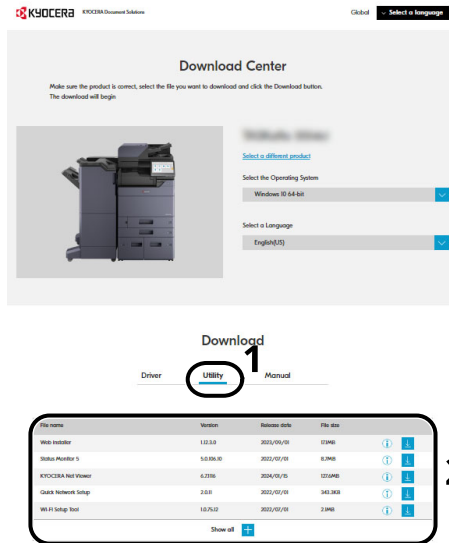

- 6 Double-click the downloaded installer to launch.



NOTE

- Installation on Windows must be done by a user logged on with administrator privileges.
- If the user account management window appears, click [Yes].

6 Configure the settings

- 1 [Do not use WPS] > [Next] > [Next]

- 2 [Wi-Fi Direct] > [Next] > [Next]

- 3 [Detail Settings] > [Next]

Select either [Express] or [Custom] from the detection methods of the machine. You can specify an IP address or hostname as the discovery method.

- 4 Select the machine > [Next]

- 5 Select [Use Device Settings.] from [Authentication Mode] and enter [Login User Name] and [Login Password] > [Next]

Enter administrator's Login User Name and Login Password.

- 6 Configure the communication settings and click [Next].

- 7 Change the settings of access point as necessary > [Next]

The network is configured.

Setting Wi-Fi Direct

After configuring the connection settings, you will be able to print in the Wi-Fi Direct environment. The configuration methods are as follows:

- Configuring the connection from the operation panel on this machine
- Configuring the connection by using push button

Connecting to Computers or Mobile Devices that Support Wi-Fi Direct

1 Display the screen

[System Menu/Counter] key > [▲][▼] keys > [System/Network] > [OK] key > [▲][▼] keys > [Network Setting] > [OK] key > [▲][▼] keys > [Wi-Fi Direct Set] > [OK] key > [▲][▼] keys > [Wi-Fi Direct] > [OK] key

2 Configure the settings

[▲][▼] keys > [On] > [OK] key

3 Restart the network.

[System Menu/Counter] key > [▲][▼] keys > [System/Network] > [OK] key > [▲][▼] keys > [Network Setting] > [OK] key > [▲][▼] keys > [Restart Network] > [OK] key > [Yes]

4 Specify the machine from the computer or mobile device.

If a confirmation message appears on the operation panel of the machine, select [Yes].

The network between this machine and the computer or mobile device is configured.

Connecting to Computers or Mobile Devices Unsupported Wi-Fi Direct

Here, we'll explain the procedures for connecting to iOS mobile devices.

1 Display the screen

[System Menu/Counter] key > [▲][▼] keys > [System/Network] > [OK] key > [▲][▼] keys > [Network Setting] > [OK] key > [▲][▼] keys > [Wi-Fi Direct Set] > [OK] key > [▲][▼] keys > [Wi-Fi Direct] > [OK] key

2 Configure the settings

[▲][▼] keys > [Enable] > [OK] key

3 Restart the network.

[System Menu/Counter] key > [▲][▼] keys > [System/Network] > [OK] key > [▲][▼] keys > [Network Setting] > [OK] key > [▲][▼] keys > [Restart Network] > [OK] key > [Yes]

4 [Wi-Fi Direct] > [OK] key > [▲][▼] keys > [Detail Setting] > [OK] key

5 Note the network name (SSID), IP address, and password

6 Use the [◀][▶] keys to check the network name (SSID), password, and IP address, and note them.

7 Configure the mobile device.

1 [Setting] > [Wi-Fi]

2 Select the network name (SSID) appeared in step 5 from the list.

3 Enter the password that was provided in step 5 > [Connected]

The network between this machine and the computer or mobile device is configured.

Configuring the connection by using push button

When your computer or mobile device does not support Wi-Fi Direct but supports WPS, you can configure the network using push button.

1 Display the screen

[System Menu/Counter] key > [▲][▼] keys > [System/Network] > [OK] key > [▲][▼] keys > [Network Setting] > [OK] key > [▲][▼] keys > [Wi-Fi Direct Set] > [OK] key > [▲][▼] keys > [Wi-Fi Direct] > [OK] key

2 Configure the settings

[▲][▼] keys > [On] > [OK] key

3 Restart the network.

[System Menu/Counter] key > [▲][▼] keys > [System/Network] > [OK] key > [▲][▼] keys > [Network Setting] > [OK] key > [▲][▼] keys > "Restart Network" > [OK] key > [Yes]

4 [Wi-Fi Direct] key > [▲][▼] keys > [PushButton Setup] > [OK] key

5 Press the push button on the computer or mobile device to be connected > [Next]

The network between this machine and the computer or mobile device is configured.



IMPORTANT

You can connect up to 1010 mobile devices at the same time using Wi-Fi Direct setting. When the devices that support Wi-Fi Direct are connected, if you want to connect other device, disconnect the already connected devices from the network. The disconnection methods are as follows:

- Disconnect the network from the computer or handheld computer
- Disconnecting all devices from the network on the operation panel

Select [Wi-Fi Direct] key > [▲][▼] keys > [ConnectionStatus] > [OK] key [Menu] > [▲][▼] keys > [Disconnect] > [OK], in that order.

- Configuring auto disconnecting time from the System menu
 - ➔ [\[Wi-Fi Direct Set\] \(page 377\)](#)
 - Configuring auto disconnecting time from the Command Center RX
 - ➔ **Command Center RX User Guide**
-

Energy Saver function

If a certain period of time elapses after the machine is last used, the machine automatically enters Sleep to minimize power consumption.

Sleep

To enter Sleep, select the key, message display and all indicators on the operation panel will go out to save a maximum amount of power except the Energy Saver indicator. This status is referred to as Sleep.

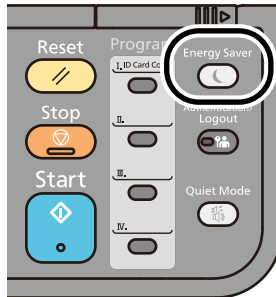

If print data is received during Sleep, the machine automatically wakes up and starts printing.

For fax-compatible models, when fax data arrives while the machine is in Sleep, the machine automatically wakes up and starts printing.

In addition, the machine wakes up when the following operations are performed:

- Select the [Energy Saver] key.

Recovery time from Sleep Mode is as follows.

10 seconds or less

Note that ambient environmental conditions, such as ventilation, may cause the machine to respond more slowly.

Auto Sleep

Function that automatically switches the machine into Sleep if left idle for a preset time. The amount of time before entering Sleep is 1 minute (default setting).

When using this machine, select the [Energy Saver] key.

Note that ambient environmental conditions, such as ventilation, may cause the machine to respond more slowly.

For the procedure for specifying the switch time for the sleep function, refer to the following:

➔ [Sleep Timer \(page 443\)](#)

Sleep Level (Energy Saver mode and Quick Recovery mode)

Sleep can be switched to two modes: Energy Saver mode and Quick Recovery mode. The default setting is Energy Saver mode.

Energy saver mode allows for the per function setting of whether to operate sleep mode in a state that uses even less energy than Return Priority mode. IC card is also not recognized.

Selecting the [Energy Saver] key on the operation panel will recovery immediately. Further, if print data is received during Sleep, the machine automatically wakes up and starts printing.

NOTE

Use the Energy Saver mode under normal circumstances. Use the Quick Recovery mode only when the computer does not recognize USB-connected devices. Note that this will consume more power.

→ [Sleep Level \(page 442\)](#)

The procedure for selecting a sleep level and using Energy Saver for each function is explained below.

1 Display the screen.

[System Menu/Counter] key > [▲][▼] keys > [Common Settings] > [OK] key > [▲][▼] > [Timer Setting] > [OK] key > [▲][▼] > [Sleep Level] > [OK] key

2 Select the Sleep Level

[▲][▼] keys > [Quick Recovery]/> or [Energy Saver]/> > [OK] key

If [Energy Saver] is set, perform the following procedure and select whether or not to use the Energy Saver mode for each function.

3 Configure the Sleep Rule

1 Select the function to be set and select the [OK] key.

[Card Reader] is displayed when the optional Card Authentication Kit is activated.

[FAX] is displayed only on products with the fax function installed.

2 [▲][▼] keys > [Off] or [On] > [OK] key

Configure other functions by repeating procedures 3-1 and 3-2.

Energy Saver Recovery Level

This machine can reduce power consumption when recovering from Energy Saver Mode. For Energy Saver Recovery Level, [Full Recovery], [Normal Recovery], or [Power Saving] can be selected. The factory default is [Normal Recovery].

For more information on Energy Saver Mode settings, refer to the following:

➔ [Sleep Level \(page 442\)](#)

Use the quiet mode.

The operating sound of the machine can be suppressed. Set Quiet Mode if you are concerned about the operating sound. If [Quiet Mode] is selected, the [Quiet Mode] key will light and quiet mode will be set.

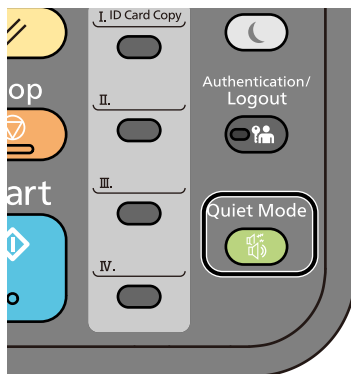

NOTE

In Quiet Mode, the processing speed will be slower than normal.

Installing Software

To use printer function, TWAIN/WIA connection, or network fax function, download and install the required software from Download Center (<https://kyocera.info/>).

Published Software (Windows)

Software	Description	Recommended software
KX DRIVER	This driver enables files on a computer to be printed by the machine. Multiple page description languages (PCL XL, KPDL, etc.) are supported by a single driver. This printer driver allows you to take full advantage of the features of the machine. Use this driver to create PDF files.	○
KPDL mini-driver/PCL minidriver	This is a Microsoft MiniDriver that supports PCL and KPDL. There are some restrictions on the machine features and option features that can be used with this driver.	—
FAX Driver	This makes it possible to send a document created in a computer software application as a fax via the machine.	—
Kyocera TWAIN Driver	This driver enables scanning on the machine using a TWAIN compliant software application.	○
WIA Driver	WIA (Windows Imaging Acquisition) is a function of Windows that enables reciprocal communication between an imaging device such as a scanner and an image processing software application. An image can be acquired using a WIA-compliant software application, which is convenient when a TWAIN-compliant software application is not installed in the computer.	—
KYOCERA Net Viewer	This is a utility that enables monitoring of the machine on the network.	—
Status Monitor 5	This is a utility that monitors the printer status and provides an ongoing reporting function.	○
KYOCERA Net Direct Print	This makes it possible to print a PDF file without starting Adobe Acrobat/Reader.	—
KYOCERA Quick Scan	This is a tool that allows you to configure settings for saving or sending scanned originals from your computer.	—
FONTS	These are display fonts that enable the machine's built-in fonts to be used in a software application.	○
Quick Network Setup Tool	A tool to configure the network (wired LAN) settings of the machine.	—
Wi-Fi Setup Tool	A tool to configure the wireless network (wireless LAN) settings of the machine.	—
Scan to Folder Setup Tool for SMB	A tool for creating shared folders on your PC, setting the created shared folders as destination folders on this machine, and the like.	—

Software	Description	Recommended software
Kyocera Cloud Access	Software that enables the use of cloud services from this product.	—
Kyocera Cloud Access Client	Software that enables the use of cloud services from this product. Follow the guidance on the screen to install the software.	—

 **NOTE**

- Installation on Windows must be done by a user logged on with administrator privileges.
 - The fax function can be used on products equipped with fax capability.
-

Published Software (Mac)

Software	Description	Recommended software
Mac Driver	This driver enables files on Mac to be printed by the machine. Multiple page description languages (PCL, KPD, and PDF) are supported by a single driver. This printer driver allows you to take full advantage of the features of the machine.	—

Installing Software in Windows

Downloading and installing from the website

Download and install a software from our website.

1 Download a software from the website.

- 1 Launch your Web browser.
- 2 Enter "https://kyocera.info/" to the browser's address bar or location bar.



- 3 Enter and search the product name, and select this product from the candidate list.

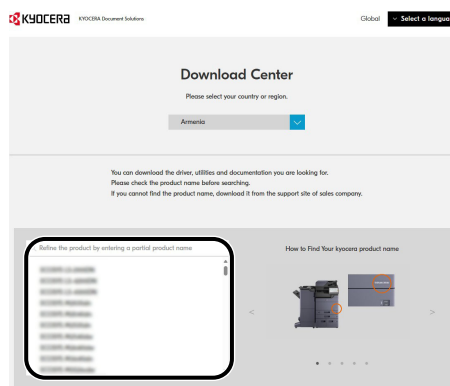

- 4 Change the selected operating system and its language setting as needed.

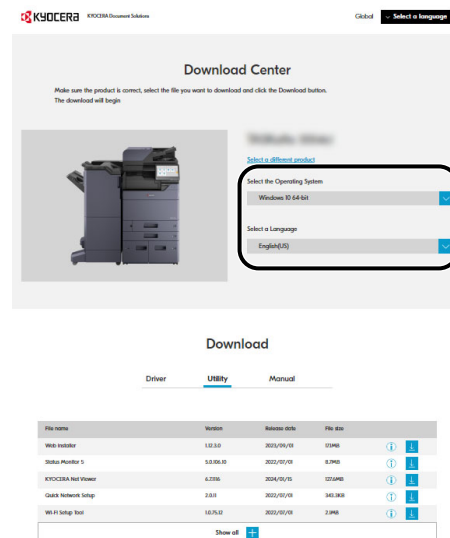

5 Driver tab or Utility tab >  of the software you want to download.

An installer of the selected software will be downloaded.

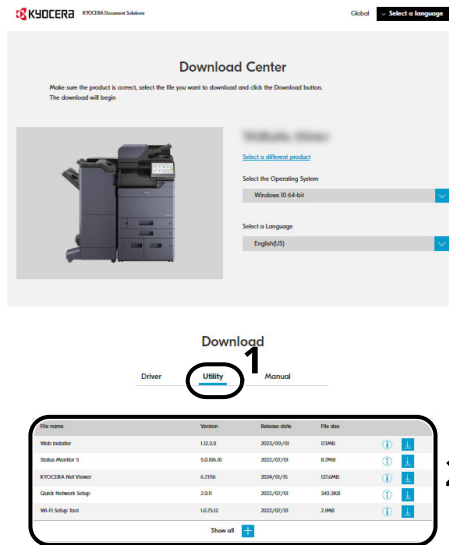

2 **Double-click the downloaded installer to launch.**

Follow the guidance on the screen to install the software.



NOTE

- Installation on Windows must be done by a user logged on with administrator privileges.
- If the user account management window appears, click [Yes].

Using the web installer

Install a software by using a web installer downloaded from our website.

1 Download a software from the website.

- 1 Launch your Web browser.
- 2 Enter "https://kyocera.info/" to the browser's address bar or location bar.



- 3 Enter and search the product name, and select this product from the candidate list.

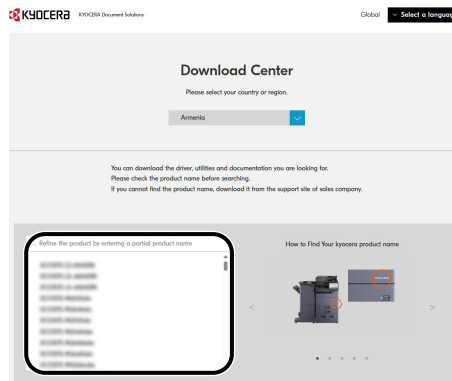

- 4 Change the selected operating system and its language setting as needed.

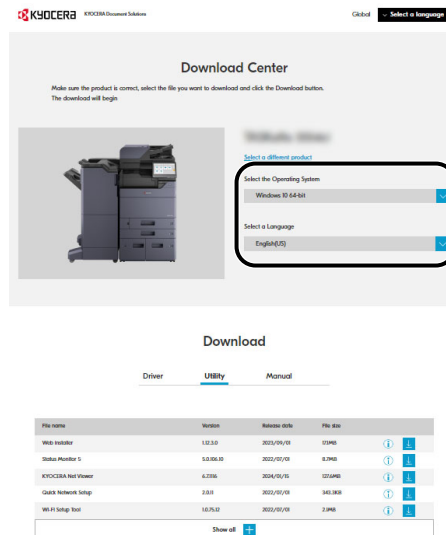

5 Utility tab >  of "Web Installer".

A web installer will be downloaded.

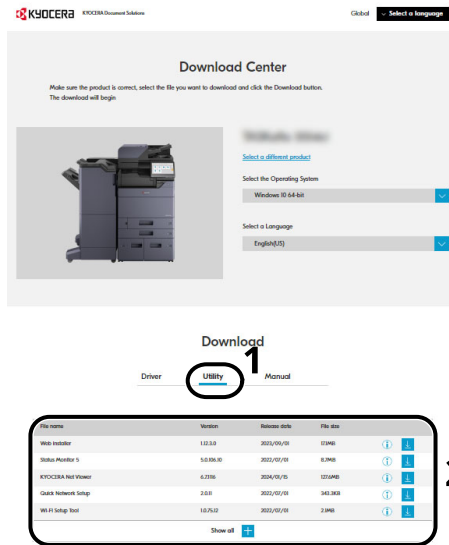

2 Double-click the downloaded installer to launch.

 NOTE

- Installation on Windows must be done by a user logged on with administrator privileges.
- If the user account management window appears, click [Yes].

3 Display the screen

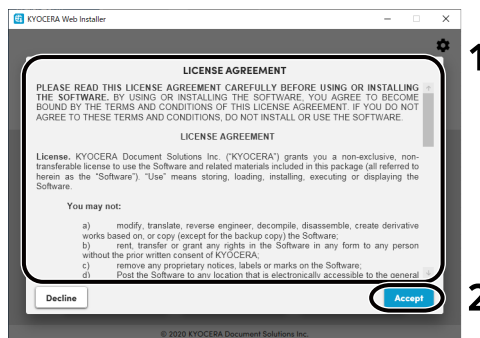

- 1 Read the license agreement.
- 2 Click [Accept] if there is no problem.

4 Click [Install].

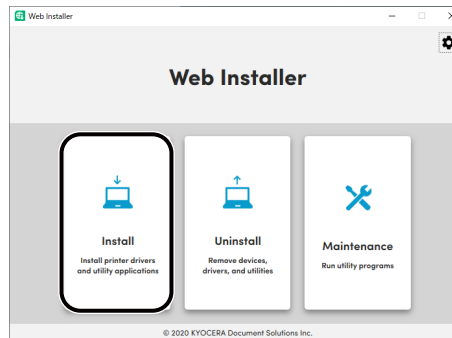

5 Select a model > [Next]

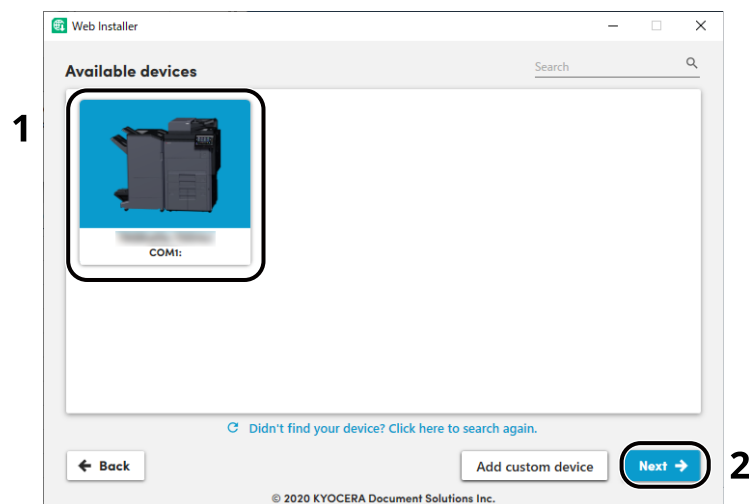

NOTE

- The machine cannot be detected unless it is on. If the computer fails to detect the machine, verify that it is connected to the computer via a network or USB cable.
- If a desired device is not displayed, select [Add Custom Device] to directly select the device you want to use.

6 Install an application.

- 1 Select software you want to install.

 **NOTE**

Software recommended to install have in their checkboxes by default. Change the settings as required.

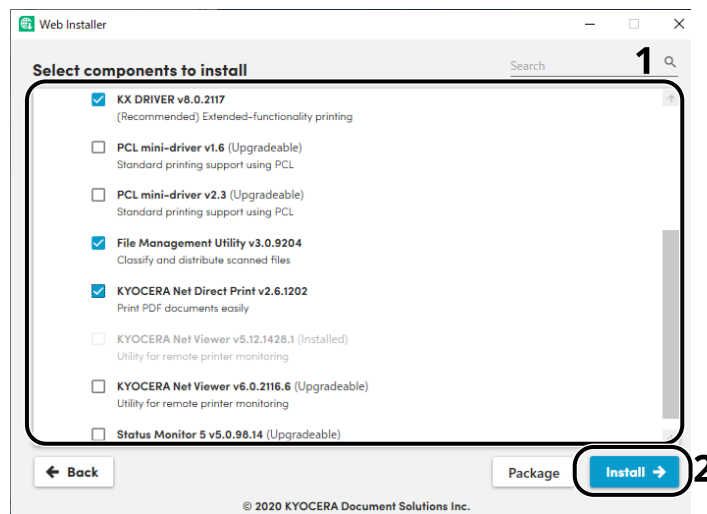

- 2 Click [Install].

 **NOTE**

If the Windows security window appears, click [Install this Driver Software].

7 Finish the installation.

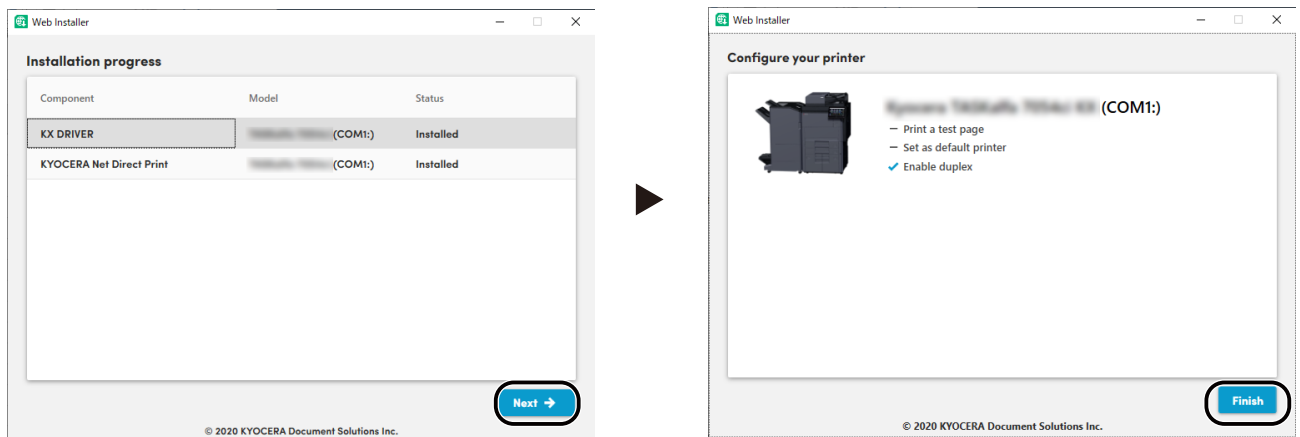

Click [Next] > [Complete] to finish the installation wizard.

If a system restart message appears, restart the computer by following the screen prompts. This completes the printer driver installation procedure.

If you are installing the TWAIN driver, continue by configuring the following:

➔ [Configure TWAIN Driver. \(page 103\)](#)

Uninstalling Windows Software

Use a web installer to uninstall software. The web installer can be downloaded from the Download Center (<https://kyocera.info>).



NOTE

For details on how to download the web installer, refer to the following:

→ [Using the web installer \(page 91\)](#)

1 Double-click the downloaded installer to launch.



NOTE

Uninstallation on Windows must be done by a user logged on with administrator privileges.

2 Display the screen

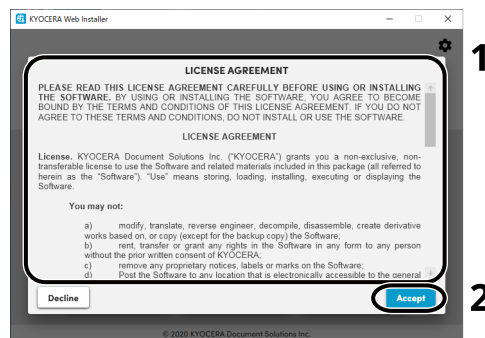

- 1 Read the license agreement.
- 2 Click [Accept] if there is no problem.

3 Click [Uninstall].

4 Uninstall the software.

- 1 Select software you want to uninstall.

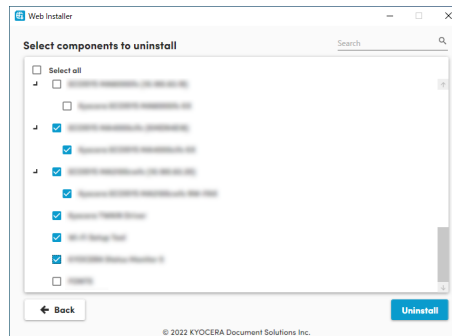

- 2 Click [Uninstall].

5 Finish uninstalling.

Click [Complete].

Restart the system for the uninstall to take effect.

Installing Software on a Mac OS Computer

A printer driver can be installed for a Macintosh computer.

NOTE

- Installation on Mac OS must be done by a user logged on with administrator privileges.
- When installing for a Mac, set the machine's emulation to [KPD] or [KPD (Auto)].
→ [\[Printer\] \(page 467\)](#)
- If connecting by Bonjour, enable Bonjour in the machine's network settings.
→ [\[Bonjour\] \(page 390\)](#)
- In the Authenticate screen, enter the name and password used to log in to the operating system.
- When printing via AirPrint, you do not have to install the software.

1 Download a software from the website.

- 1 Launch your Web browser.
- 2 Enter "<https://kyocera.info/>" into the address bar.

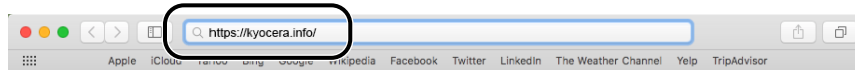

- 3 Enter and search the product name, and select this product from the candidate list.

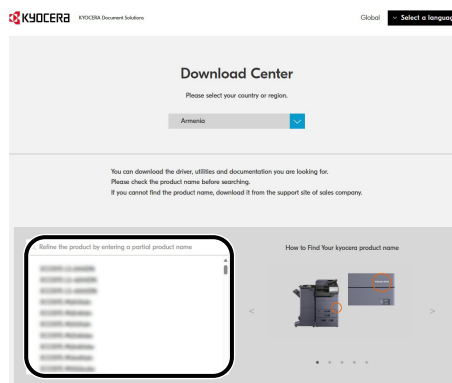

4 Change the selected operating system and its language setting as needed.

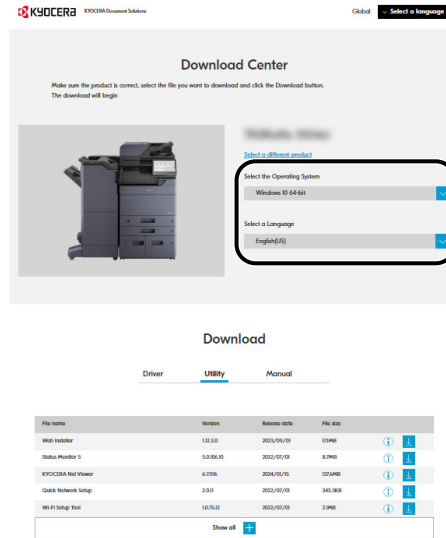

5 Driver tab > "Mac Printer Driver (x.x and later)"

An installer of the selected software will be downloaded.

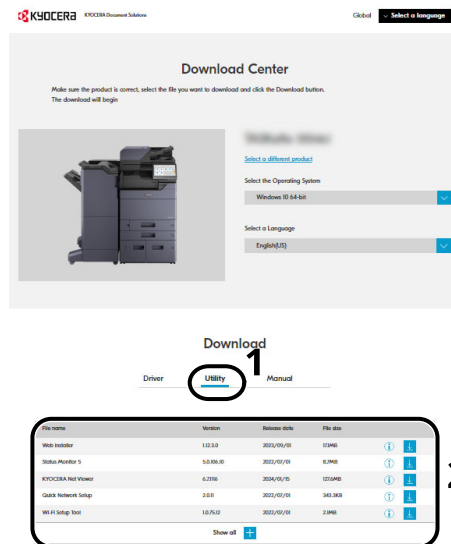

2 Install an application.

Double-click the downloaded installer to launch.

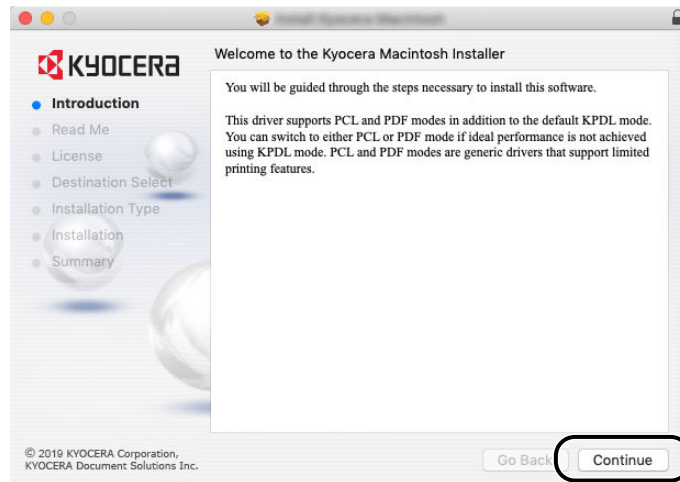

Install the printer driver as directed by the instructions in the installation software. This completes the printer driver installation.

If a USB connection is used, the machine is automatically recognized and connected. If an IP connection is used, the settings below are required.

3 Configure the settings

- 1 Open System Preferences and add the printer.

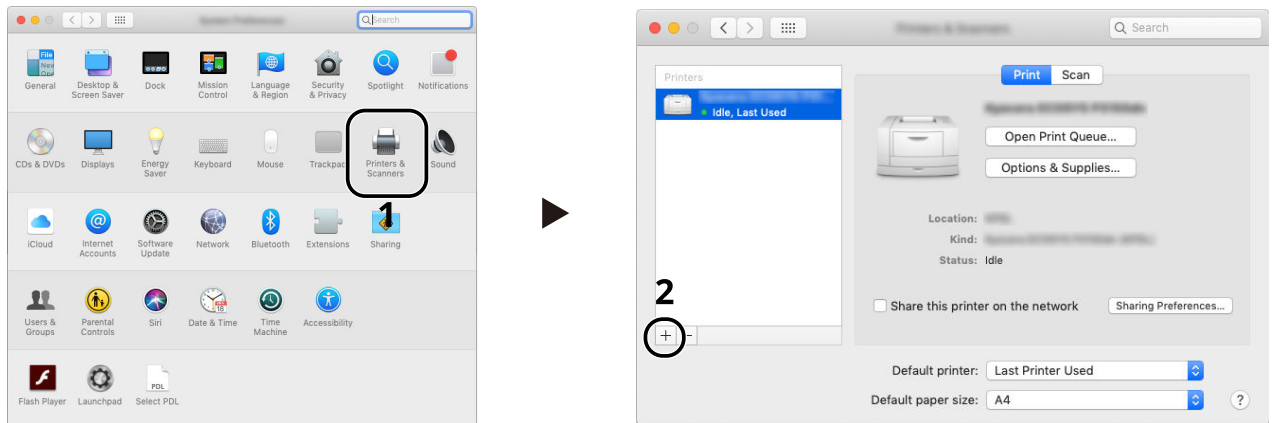

- 2 Select [Default], click the item that appears in "Name", and then select the driver.

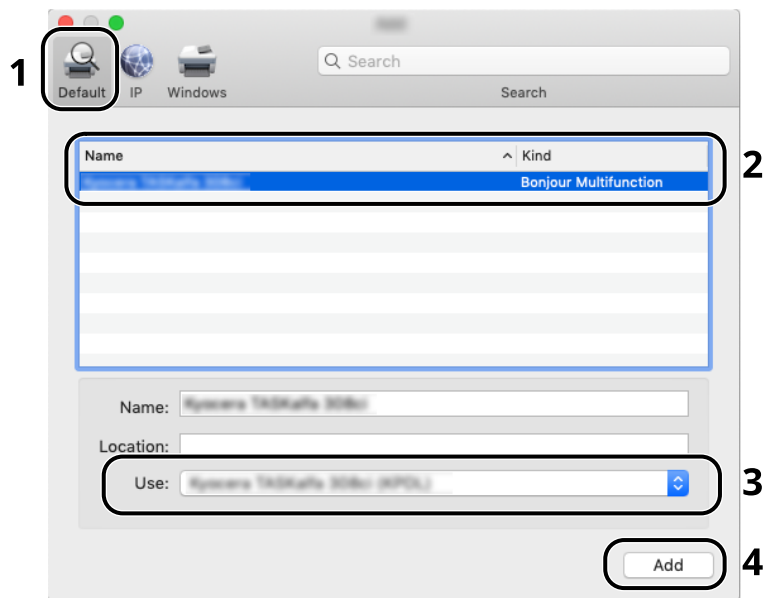

The selected machine is added.

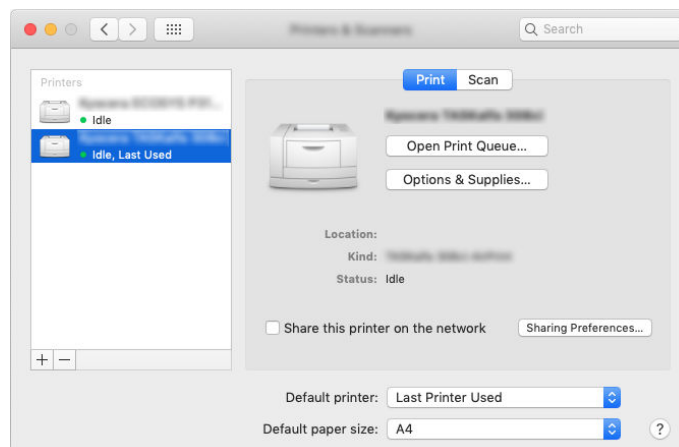

 **NOTE**

When using an IP address, select the [IP] and then enter the host name or IP address. "Name" is automatically filled in with the number entered in "Address". Change the settings as required.

3 Select the options equipped with the machine.

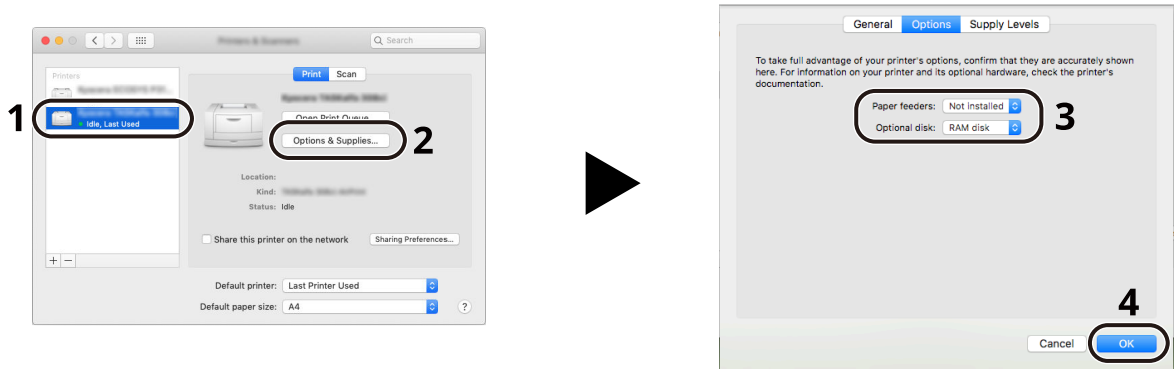

Configure TWAIN Driver.

Register this machine to the TWAIN Driver. Instructions are based on interface elements as they appear in Windows 10.

1 Display the screen

- 1 Click the search box in the taskbar, and enter "TWAIN Driver Setting". Select [TWAIN Driver Setting] in the search list. Displays the TWAIN Driver Settings screen.
- 2 Click [Add].

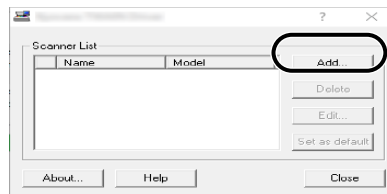

2 Configure TWAIN Driver.

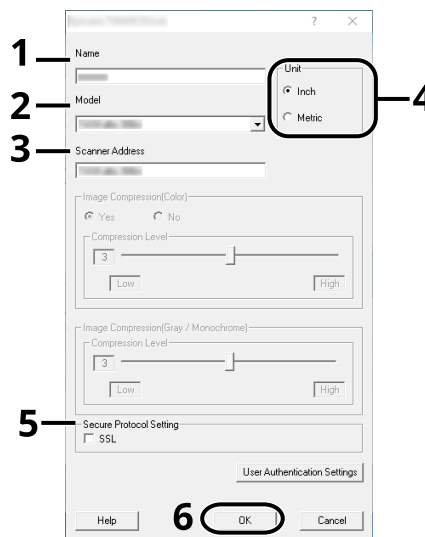

- 1 Enter the machine name.
- 2 Select this machine from the list.
- 3 Enter the machine's IP addresses or host name.
- 4 Set units of measurement.
- 5 When using SSL, select the checkbox beside SSL.

6 Click [OK].

 **NOTE**

When the machine's IP address or host name is unknown, contact Administrator.

3 Finish registering.

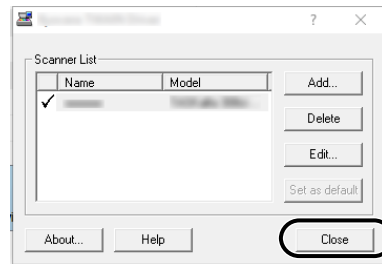

 **NOTE**

Click [Delete] to delete the added machine. Click [Edit] to change names.

Configure WIA Driver.

Register this machine to the WIA Driver. Instructions are based on interface elements as they appear in Windows 10.

1 Display the screen

- 1 Click [Search] in taskbar, and enter "View scanners and cameras" in the search box. Select [View scanners and cameras] in the search list then the Scanners and Cameras screen appears.



NOTE

For Windows 11, select the Windows [Start] button → [All apps] → [Windows Tools] → [Control Panel], in that order. Enter "Scanner" into the search field on the control panel. Select [View scanners and cameras] in the search list then the Scanners and Cameras screen appears.

- 2 Select the same name as this machine from WIA Drivers, and click the [Properties] button.

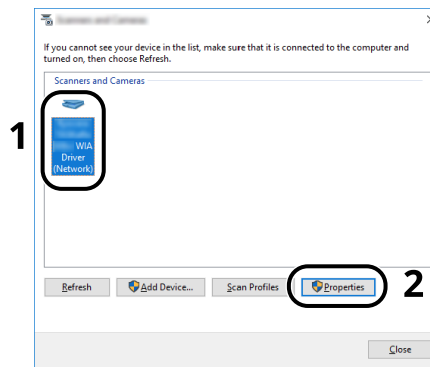

2 Configure WIA Driver.

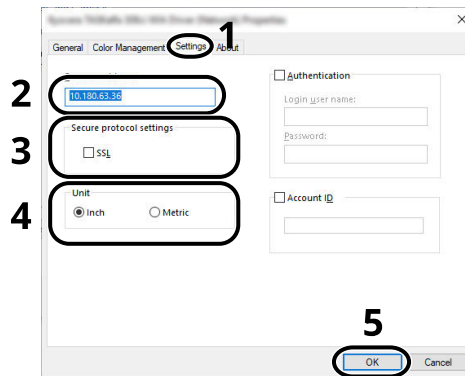

- 1 Click the [Settings] tab.
- 2 Enter the machine's IP addresses or host name.
- 3 When using SSL, select the checkbox beside SSL.
- 4 Set units of measurement.
- 5 Click [OK].

Check the counter

Check the number of sheets printed and scanned.

1 Display the screen

[System Menu/Counter] key > [▲][▼] keys > [Counter] > [OK] key

2 Check the counter

Select the item you wish to check, and select the [OK] key.

Additional Preparations for the Administrator

Administrator Privileges Overview

This machine is shipped with two default users registered one with Machine Administrator privileges, and another with Administrator privileges. The user with Machine Administrator privileges and the user with Administrator privileges can configure important settings for the machine. The differences in the privileges are as follows:

User with Machine Administrator privileges

This user can configure the product's network settings, security settings such as user registration, and the machine's security level.

➔ [\[Data Security\] \(page 407\)](#)

User with Administrator privileges

This user can configure the product's network settings, and security settings such as user registration. This user cannot set the machine's security level.

Log in as Machine Administrator or Administrator

 **NOTE**

The user with Machine Administrator privileges or the user with Administrator privileges must log in to configure important settings for the product, such as network settings and security settings. The factory default login user name and login password are set as shown below.

Machine Administrator

User Name	DeviceAdmin
Login user name	4000
Login Password	4000

Administrator

User Name	Admin
Login user name	Admin
Login Password	xxxxxxxx (Serial Number) ➔ Checking the Equipment's Serial Number (page 2)

 **IMPORTANT**

To ensure security, be sure to change the factory default user name, login user name, and login password. Also, change your password regularly.

➔ [Change the user properties \(page 491\)](#)

Strengthening the Security

This machine is shipped with two default users registered one with Machine Administrator rights, and another with Administrator rights. Logging in as this user will allow you to configure all settings; therefore, please change the login user name and password.

In addition, this machine is equipped with user authentication function, which can be configured to limit the access to this machine to only those who have a registered login name and password. For details, refer to the following:

➔ [User Authentication and Accounting \(User Login, Job Accounting\) \(page 481\)](#)



NOTE

This product has an optional security chip called TPM (Trusted Platform Module). The encryption key used to encrypt confidential information on this machine is stored in a dedicated storage area on the TPM chip. Since this storage area cannot be read from outside the TPM, confidential information can be safely protected.

Restrict the users of the machine

- User Login
 - ➔ [Overview of User Login Administration \(page 482\)](#)
- Authentication Security
 - ➔ [Authentication Security \(page 485\)](#)
- Auto Panel Reset
 - ➔ [Auto Panel Reset \(page 442\)](#)
- ID Card Settings

The optional IC Card Authentication Kit is required.

 - ➔ [ID Card Settings \(page 510\)](#)

Restrict the basic functions that can be used

- Local Authoriz.
Local Authorization
- Group Authorization Setting
 - ➔ [Group Authorization Settings \(page 502\)](#)
- Guest Auth. Set.
 - ➔ [Guest Authorization Settings \(page 503\)](#)

Output the document stored in the machine at the time when user operates the device via operation panel

- Remote Printing
 - ➔ [\[Remote Operation\] \(page 415\)](#)

Prevent the data stored in the machine from being leaked

- PDF Encryption Functions
 - ➔ [PDF Encryption Functions \(page 329\)](#)

Completely delete the data on the machine before disposing of the machine

- DataSanitization
 - ➔ [\[Data Security\] \(page 407\)](#)

Protect the transmission from interception and wiretapping

- IPP over TLS
 - ➔ [IPP over TLS \(page 396\)](#)
- HTTPS
 - ➔ [HTTPS \(page 396\)](#)
- LDAP Security
 - ➔ **Command Center RX User Guide**
- SMTP Security
 - ➔ [SMTP \(page 395\)](#)
 - ➔ **Command Center RX User Guide**
- POP3
 - ➔ [POP3 \(page 395\)](#)
 - ➔ **Command Center RX User Guide**
- FTP Encrypted TX
 - ➔ [FTP Encrypted TX \(page 338\)](#)
- EnhancedWSD(TLS)
 - ➔ [EnhancedWSD\(TLS\) \(page 398\)](#)
- IPSec
 - ➔ [\[IPSec\] \(page 393\)](#)
- SNMPv3
 - ➔ [SNMPv3 \(page 394\)](#)

Verify the software in the machine

- Software Verification
 - ➔ [SW Verification \(page 408\)](#)

Preventing from execution of the unauthorized programs

- Allowlisting
 - ➔ [Allowlisting \(page 418\)](#)

What is Command Center RX

If the machine is connected to the network, you can configure various settings using Command Center RX. This section explains how to access Command Center RX, and how to change security settings and the host name.

➔ [Command Center RX User Guide](#)

NOTE

To fully access the features of the Command Center RX pages, you must enter the user name and password and log in. Entering the predefined administrator password allows the user to access all pages, including Document Box, and Settings/Registration on the navigation menu.

Settings that the administrator and general users can configure in Command Center RX are as follows.

Item	Description	Administrator	General User
Device Information/ Remote Operation	The machine's structure can be checked.	Yes	Yes
Job Status	Displays all device information, including print and scan jobs, storing jobs, scheduled jobs, and job log history.	Yes	Yes
Address Book	Create, edit, or delete addresses and address groups. The logged in user may not be able to configure some settings, depending on the privilege of the user.	Yes	Yes
Device Settings	Configure the advanced settings of the machine.	Yes	No
Function Settings	Configure the advanced function settings.	Yes	No
Network Settings	Configure the network advanced settings.	Yes	No
Security Settings	Configure the security advanced settings.	Yes	No
Management Settings	Configure the advanced management settings.	Yes	No

NOTE

The setting item which can be set or configured from Command Center RX.
Here, information on the FAX settings has been omitted.

➔ [FAX Operation Guide](#)

Accessing Command Center RX

1 Display the screen

- 1 Launch your Web browser.
- 2 In the address or location bar, enter the machine's IP address or the host name.
Click in the following order to check the machine's IP address and the host name.
Example: `https://10.180.81.1` (in the case of /IP address)
`https://MFP001` (if the host name is MFP001)

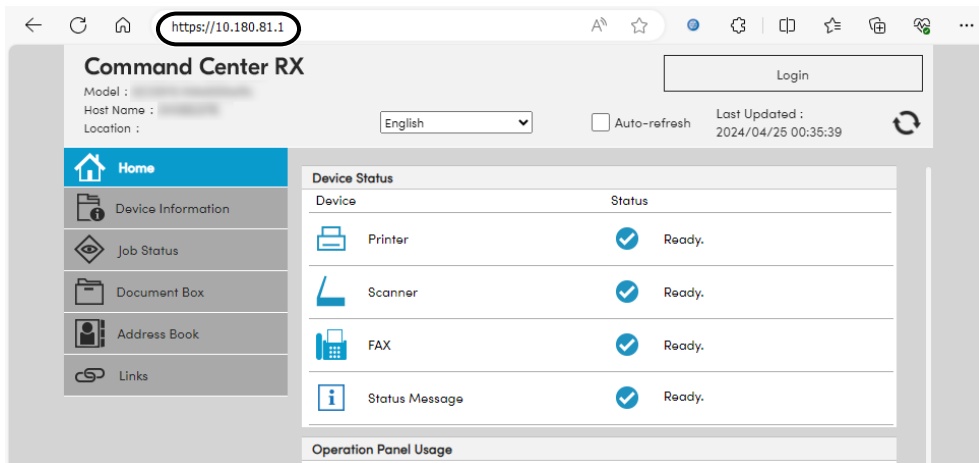

The web page displays basic information about the machine and Command Center RX as well as their current status.

NOTE

If "There is a problem with this website's security certificate" is displayed, configure the certificate.

➔ [Command Center RX User Guide](#)

You can also continue the operation without configuring the certificate.

2 Configure the settings

Select a category from the navigation bar on the left of the screen.

NOTE

To fully access the features of the Command Center RX pages, you must enter the user name and password and log in. Entering the predefined administrator password allows the user to access all pages, including Document Box, and Settings/Registration on the navigation menu.

Changing Security Settings

1 Display the screen

- 1 Launch your Web browser.
- 2 In the address or location bar, enter the machine's IP address or the host name.
Click in the following order to check the machine's IP address and the host name.
[System Menu/Counter] key > [▲][▼] keys > [Report] > [OK] key > [▲][▼] keys > [Report Print] > [OK] key > [▲][▼] keys > [Status Page] > [OK] key > [Yes]
- 3 Log in with administrator privileges.

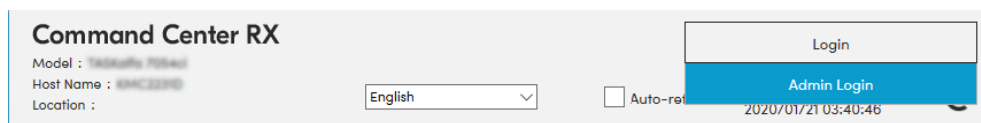

- 4 Click [Security Settings].

2 Configure the settings

From the [Security Settings] menu, select the setting you want to configure.

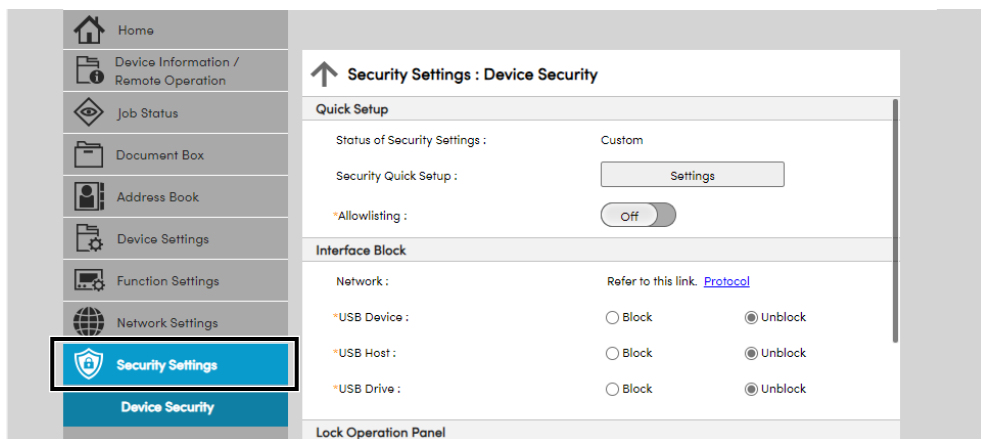

NOTE

For details on settings related to certificates, refer to the following:

➔ **Command Center RX User Guide**

Changing Device Information

1 Display the screen

- 1 Launch your Web browser.
- 2 In the address or location bar, enter the machine's IP address or the host name.
Click in the following order to check the machine's IP address and the host name.
[System Menu/Counter] key > [▲][▼] keys > [Report] > [OK] key > [▲][▼] keys > [Report Print] > [OK] key > [▲][▼] keys > [Status Page] > [OK] key > [Yes]
- 3 Log in with administrator privileges.

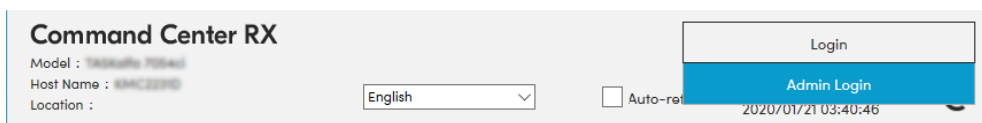

- 4 From the [Device Settings] menu, click [System].

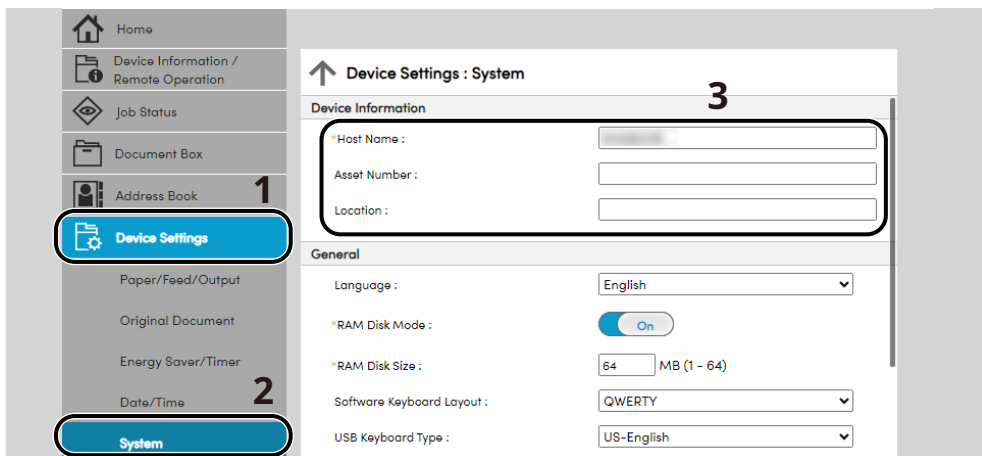

2 Configure the settings

Enter the device information, and then click [Submit].

✓ IMPORTANT

After changing the setting, restart the network or turn the machine OFF and then ON. To restart the network interface card, click [Reset] in the [Management Settings] menu, and then click [Restart Network] in "Restart".

SMTP and E-mail Settings

By configuring the SMTP settings, it is possible to send the images scanned by the machine as E-mail attachments and to send E-mail notices when jobs have been completed. To use this function, this machine must be connected to a mail server using the SMTP protocol.

In addition, configure the following.

SMTP settings

"SMTP Protocol" and "SMTP Server Name" in "SMTP"

The sender address when the machine sends E-mails

"Sender Address" in "E-mail Send Settings"

The setting to limit the size of E-mails

"E-mail Size Limit" in "E-mail Send Settings"

The procedure for specifying the SMTP settings is explained below.

1 Display the screen

Display the SMTP Protocol screen.

1 Launch your Web browser.

2 In the address or location bar, enter the machine's IP address or the host name.

Click in the following order to check the machine's IP address and the host name.

[System Menu/Counter] key > [▲][▼] keys > [Report] > [OK] key > [▲][▼] keys > [Report Print] > [OK] key > [▲][▼] keys > [Status Page] > [OK] key > [Yes]

3 Log in with administrator privileges.

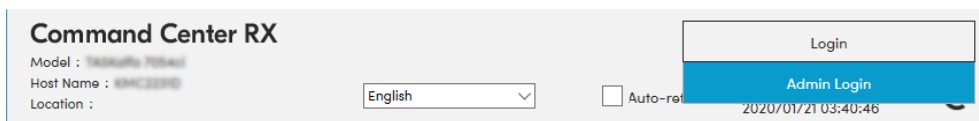

4 From the [Network Settings] menu, click [Protocol].

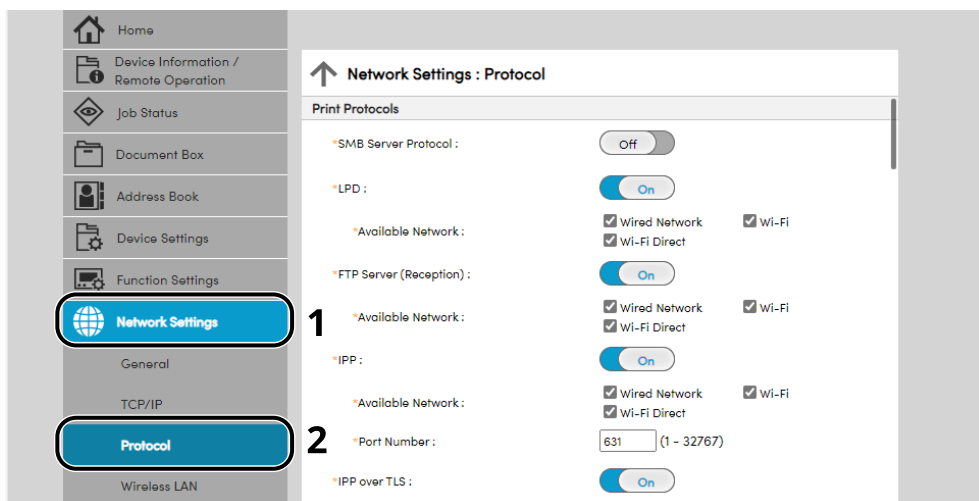

2 Configure the settings

Set "SMTP (E-mail TX)" to [On] in the "Send Protocols".

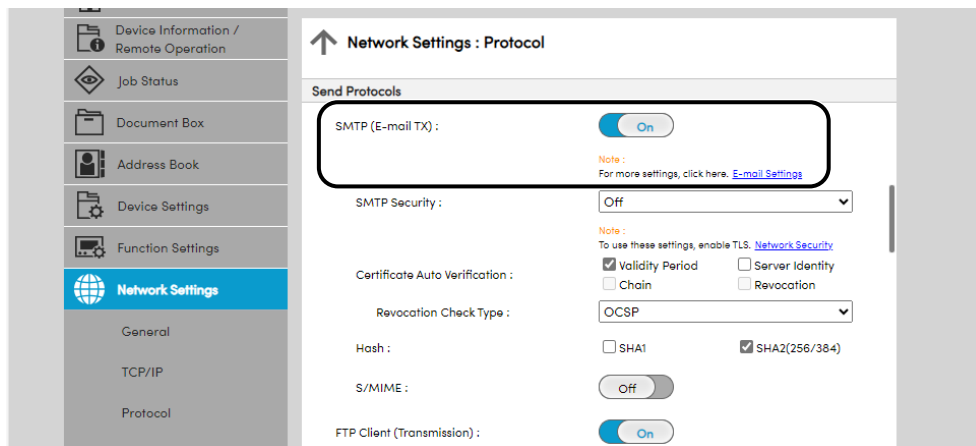

3 Display the screen

Display the E-mail Settings screen.

From the [Function Settings] menu, click [E-mail].

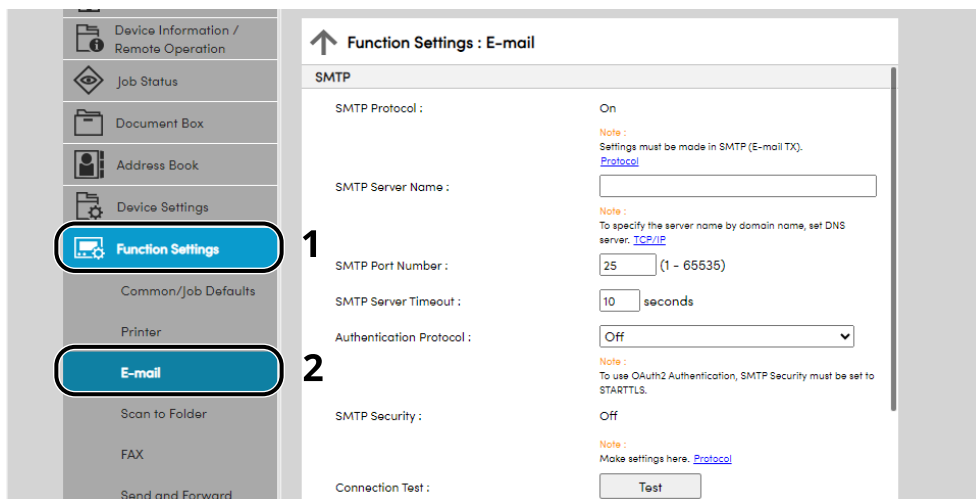

4 Configure the settings

Enter "SMTP" and "E-mail Send Settings" items.

SMTP

Set to send e-mail from the machine.

[SMTP Protocol]

Displays the SMTP protocol settings. Check that [SMTP Protocol] is set to [On]. If [Off] is set, click [Protocols] and set the SMTP protocol to [On].

[SMTP Server Name]

Enter the host name or IP address of the SMTP server. Be sure to enter the items.

[SMTP Port Number]

Specify the port number to be used for SMTP. The factory default port number is 25.

[SMTP Server Timeout]

Set the amount of time to wait before time-out in seconds.

[Authentication Protocol]

To use SMTP authentication, enter the user information for authentication.

[Connection Test]

Tests to confirm the proper operation under the settings without sending an email.

[Domain Restrictions]

To restrict the domains, click the [Domain List] and enter the domain names of addresses to be allowed or rejected. Restriction can also be specified by e-mail address.

POP3

You don't need to set the items when you only use the function of sending e-mail from the machine. Set the items if you want to enable the function of receiving e-mail on the machine.

➔ **Command Center RX User Guide**

E-mail Send Settings

[E-mail Size Limit]

Enter the maximum size of E-mail that can be sent in kilobytes. When E-mail size is greater than this value, an error message appears and E-mail sending is canceled. Use this setting if you have set E-mail Size Limit for SMTP server. If not, enter a value of 0 (zero) to enable E-mail sending regardless of the size limit. Entering 0 will allow for the sending of E-mail regardless of E-mail size limits.

[Sender Address]

Specify the sender address for when the machine sends E-mails. Non-delivery report may be sent back to the sender address specified here. It is recommended that you specify an e-mail address that can be received by the device administrator. The sender address must be entered correctly for SMTP authentication. The maximum length of the sender address is 256 characters. Be sure to enter the items.

[Signature]

Enter the signature. The signature is free form text that will appear at the end of the E-mail body. It is often used for further identification of the machine. The maximum length of the signature is 512 characters.

[SMTP Authentication and Sender Address]

Select the information source (quotation destination) for the login user name, password, and sender address used for SMTP authentication and email sending. Select [Use Device Setting] or [Use Login User Information].

[Function Default]

Change the function default settings in [Common/Job Defaults] page.

5 Click [Submit].

Registering Destinations

1 Display the screen

- 1 Launch your Web browser.
- 2 In the address or location bar, enter the machine's IP address or the host name.
Click in the following order to check the machine's IP address and the host name.
[System Menu/Counter] key > [▲][▼] keys > [Report] > [OK] key > [▲][▼] keys > [Report Print] > [OK] key > [▲][▼] keys > [Status Page] > [OK] key > [Yes]
- 3 Log in with administrator privileges.

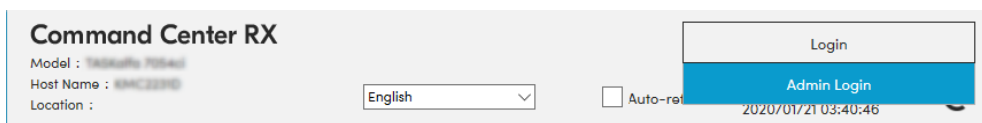

- 4 In the [Address Book] menu, click [Machine Address Book].

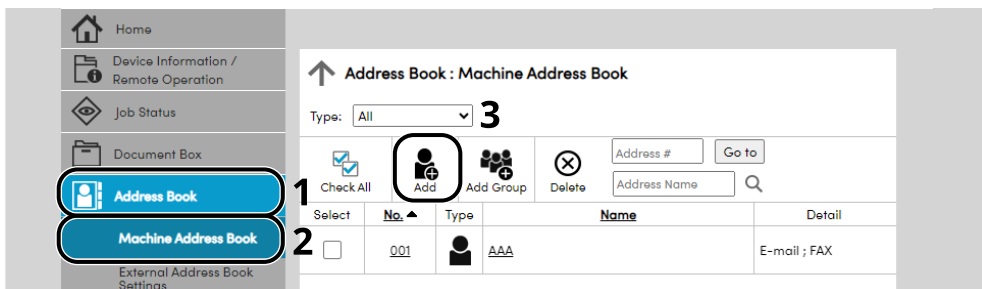

- 5 Click [Add].

2 Configure the settings.

- 1 Enter the destination information.
Enter the information for the destination you want to register. The fields to populate are the same as when registering via operation panel.
➔ [Registering Destinations in the Address Book \(page 161\)](#)
- 2 Click [Submit].

Transferring Data from Our Other Products

By using the machine's utility, you can smoothly migrate address books when the machine is to be replaced. This section explains how to transfer data between our products.

Migrating the Address Book

The Address Book registered on the machine can be backed up or migrated using the KYOCERA Net Viewer downloaded from Download Center (<https://kyocera.info/>).

For details on KYOCERA Net Viewer operation, refer to the following:

➔ **KYOCERA Net Viewer User Guide**

Backing up Address Book Data to PC

- 1 Start up KYOCERA Net Viewer.**

2 Create a backup.

- 1 Right-click on the name of the model from which you want to back up the Address Book, and select [Advanced] > [Set mutiple devices].

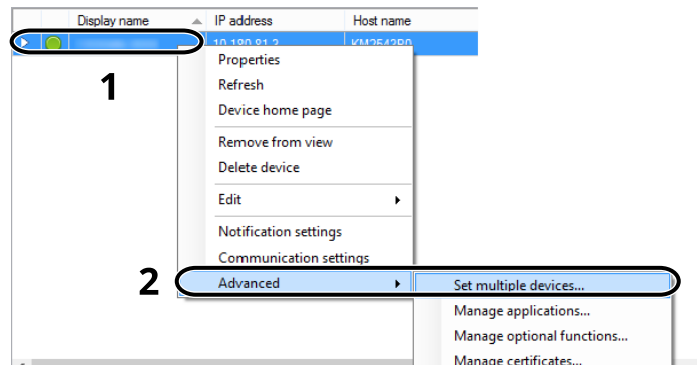

- 2 Select [Custom mode] and click [Next].

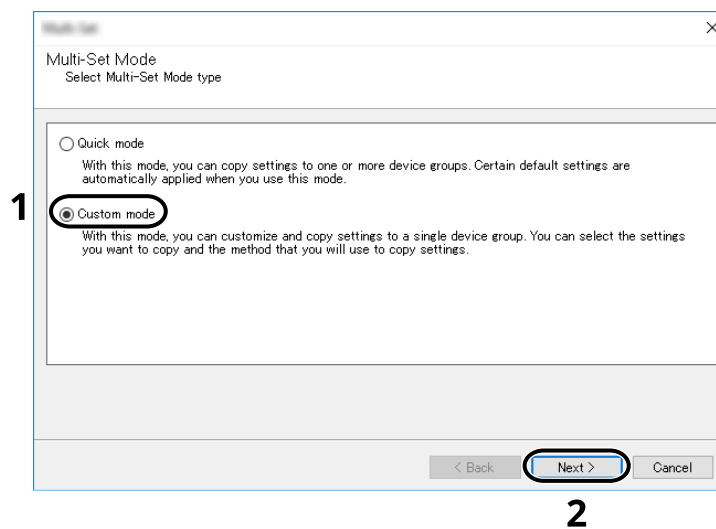

3 Select destination device group and click [Next].

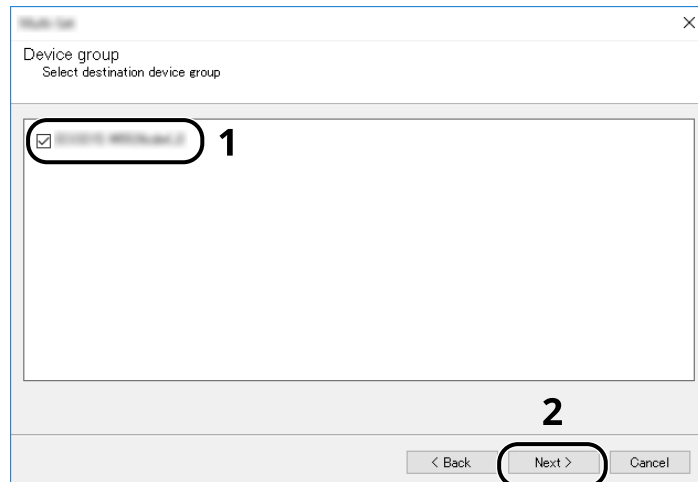

4 Select [Device Address Book] and click [Next].

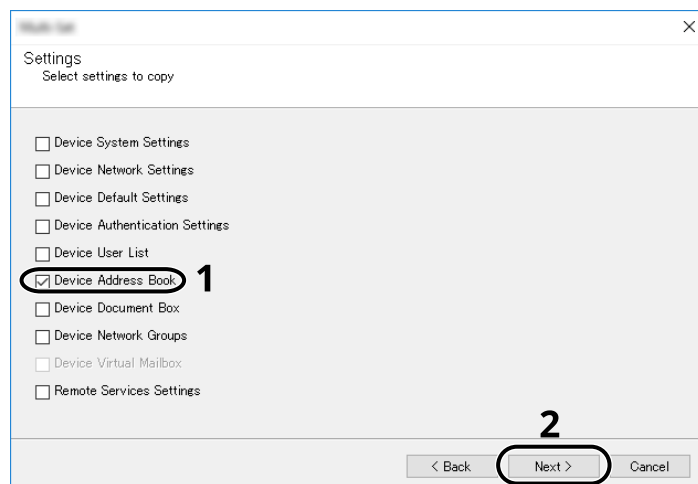

- 5 Select [Create from device], uncheck [Overwrite settings on target device], and click [Next].

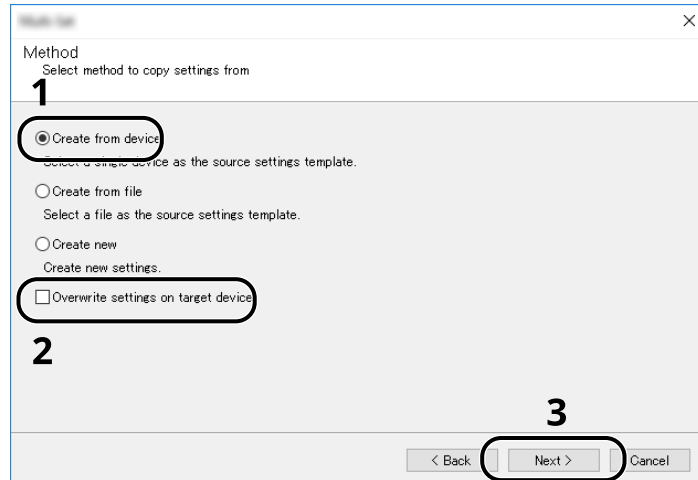

- 6 Select the model you want to back up, and click [Next].

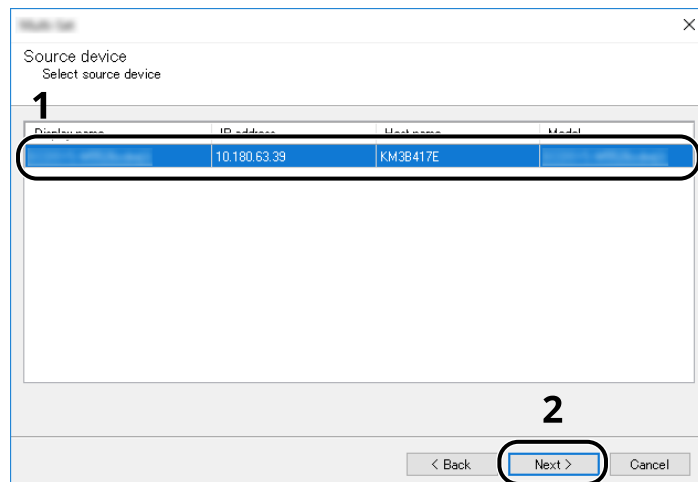

 **NOTE**

If the "Administrator login" screen appears, enter the administrator's login user name and password, and then click [OK].

- 7 Click [Save to file].

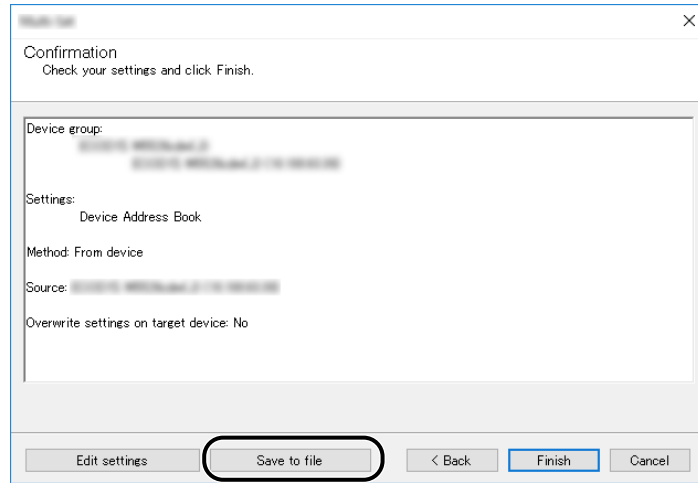

- 8 Specify the location to save the file, enter the file name, and then click [Save]. Be sure to select "XML file" for "File format".
- 9 After saving the file, always click [Cancel] to close the screen.

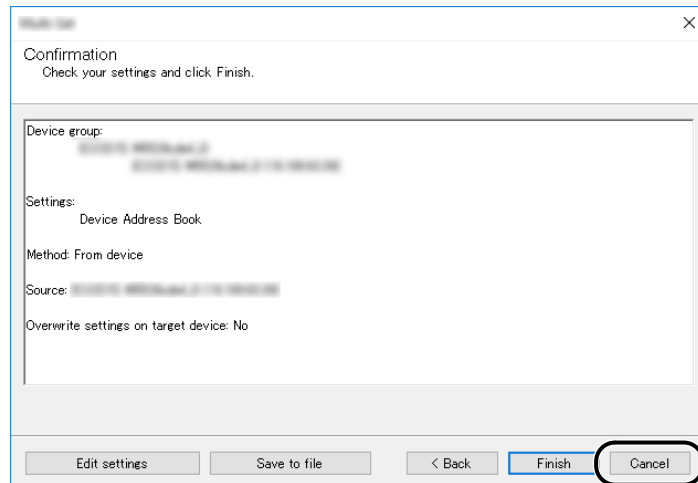

Please note that selecting [Finish] will write the data to the machine's Address Book.

Writing Address Book Data to the Machine

1 Start up KYOCERA Net Viewer.

2 Load the Address Book data.

- 1 Right-click on the name of the model from which you want to forward the Address Book, and select [Advanced] > [Set mutiple devices].

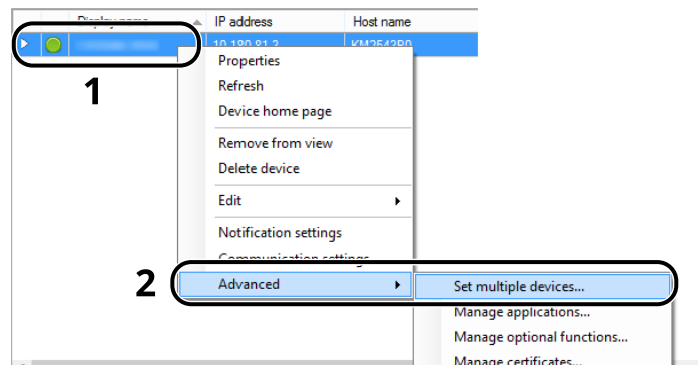

- 2 Select [Custom mode] and click [Next].

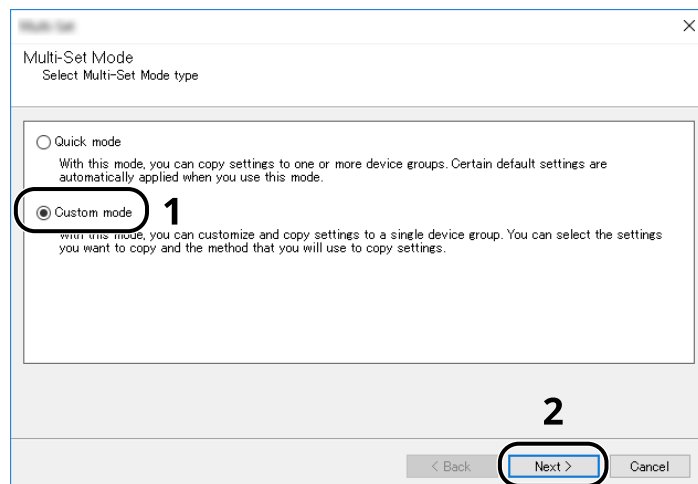

- 3 Select a destination device group and click [Next].

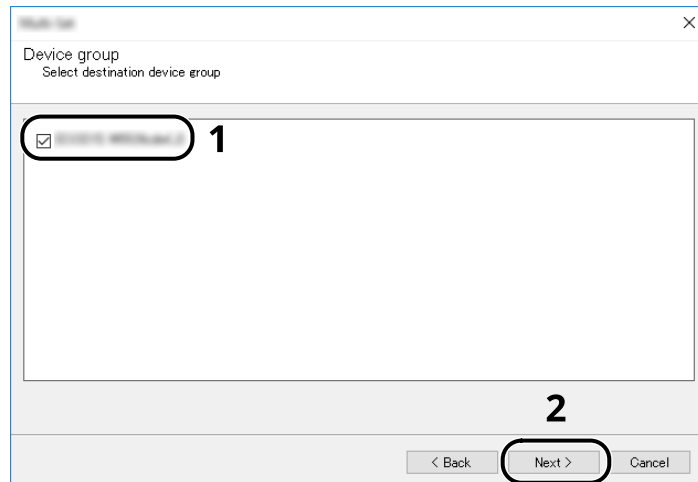

- 4 Select [Device Address Book] and click [Next].

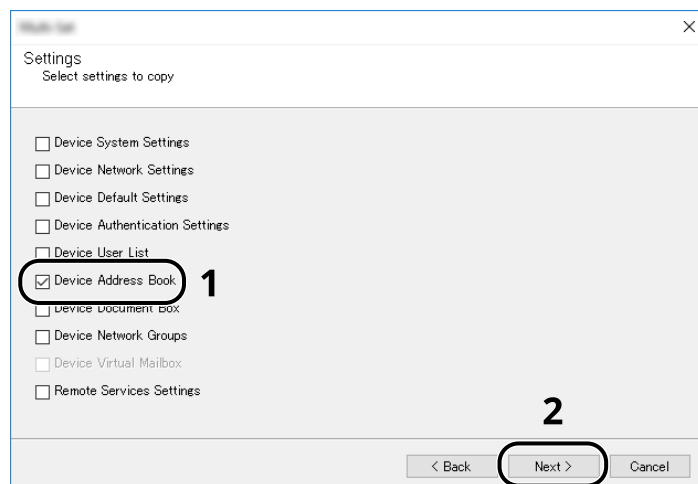

- 5 Select [Create from file], uncheck [Overwrite settings on target device], and click [Next].

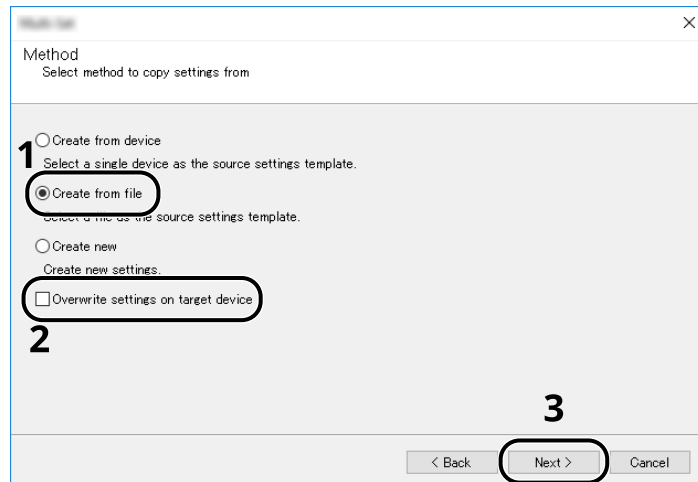

Selecting the [Overwrite settings on target device] checkbox will overwrite the machine's Address Book from entry No.1.

- 6 Click [Reference] and select the backup Address Book file, and then click [Next].
- 7 Click [Fininsh].

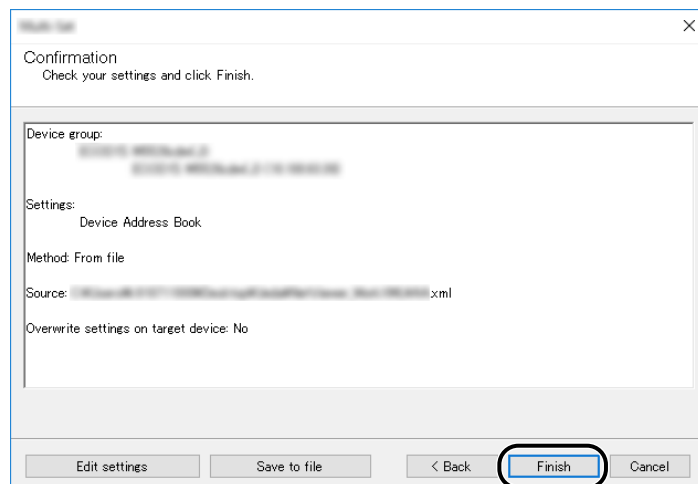

The write process of the Address Book data starts.

- 8 Once the write process is complete, click [Close].

3 Preparation before Use

Load paper

Loading Paper

Load paper in the cassettes and multipurpose tray.

For the paper load methods for each cassette, refer to the page below.

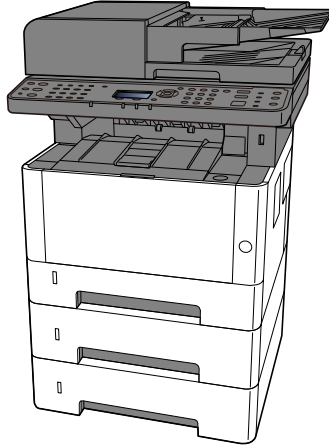

1 Cassette 1

➔ [Loading in the Cassettes \(page 133\)](#)

2 Cassette 2

➔ [Loading in the Cassettes \(page 133\)](#)

3 Cassette 3

➔ [Loading in the Cassettes \(page 133\)](#)

4 MultipurposeTray

➔ [Loading Paper in the Multipurpose Tray \(page 138\)](#)

 **NOTE**

- The number of sheets that can be held varies depending on your environment and paper type (thickness).
 - Do not use inkjet printer paper or paper with special coatings. (Doing so may lead to failures such as paper jams.)
-

Precaution for Loading Paper

When you open a new package of paper, fan the sheets to separate them slightly prior to loading in the following steps.

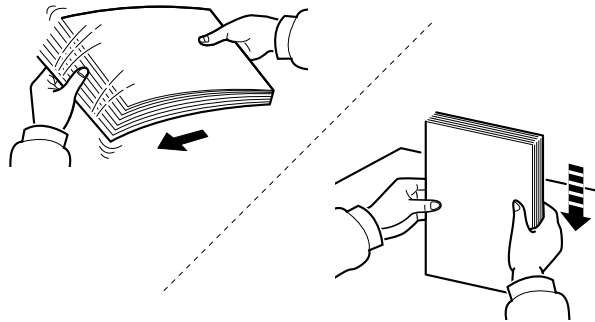

Fan the paper, then tap it on a level surface. In addition, note the following points.

- If the paper is curled or folded, straighten it before loading. Paper that is curled or folded may cause a jam.
- Avoid exposing opened paper to high temperatures and high humidity as dampness can be a cause of problems. Seal any remaining paper in the cassettes back in the paper storage bag. Seal any remaining paper after loading in the multipurpose tray in the paper storage bag.
- If the machine will not be used for a prolonged period, protect all paper from humidity by removing it from the cassettes and sealing it in the paper storage bag.

✔ IMPORTANT

If you copy onto used paper (paper already used for printing), do not use paper that is stapled or clipped together. This may damage the machine or cause poor image quality.

💡 NOTE

If you use special paper such as letterhead, paper with holes or paper with pre-prints like logo or company name, refer to the following:

➔ [About Paper \(page 769\)](#)

Paper Specifications available in the Cassettes

The cassettes can hold plain paper, recycled paper or color paper. The number of sheets that can be loaded in each cassette is shown below.

Cassette	Capacity
Cassette 1 to 3	250 sheets (Plain paper: 80 g/m ²)

For details of the supported paper sizes, refer to the following:

➔ [Choosing the Appropriate Paper \(page 770\)](#)

For the paper type setting, refer to the following:

➔ [\[Media Type Set.\] \(page 430\)](#)

 **IMPORTANT**

- Cassettes 1 to 3 can hold 80 to 163 g/m² of paper.
 - If you are using a paper weight of 106 g/m² or more, set the media type to Thick and set the weight of the paper you are using.
-

Loading in the Cassettes

- 1 Pull the cassette completely out of the machine.

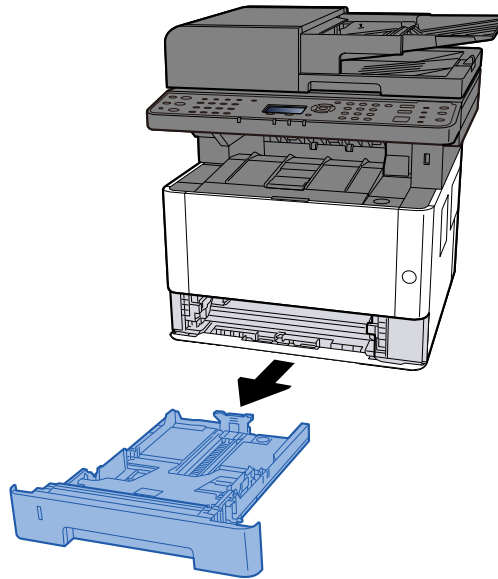

 **NOTE**

If the baseplate is rising, push the baseplate until it locks.

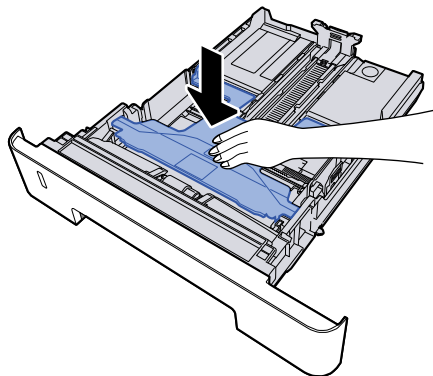

2 Adjust the cassette size.

- 1 Adjust the paper length guide to the paper size required. Press the paper length adjusting tab and slide the guides to the paper size required.

Paper sizes are marked on the cassette.

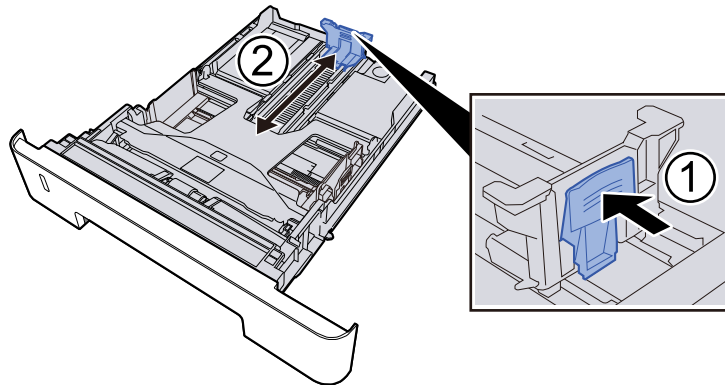

✔ IMPORTANT

When using Folio, Oficio II, or Legal

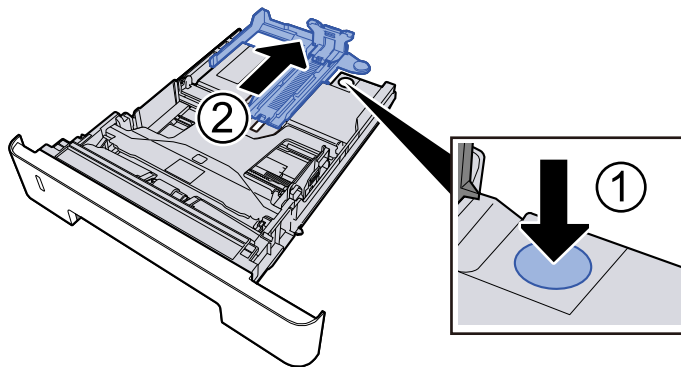

- 2 Adjust the position of the paper width guides located on the left and right sides of the cassette. Press the paper width adjusting tab and slide the guides to the paper size required.

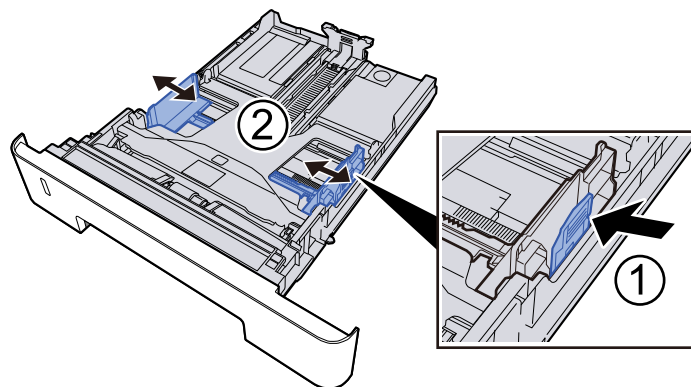

3 Load paper

- 1 Fan the paper, then tap it on a level surface to avoid paper jams or skewed printing.
- 2 Load the paper in the cassette.

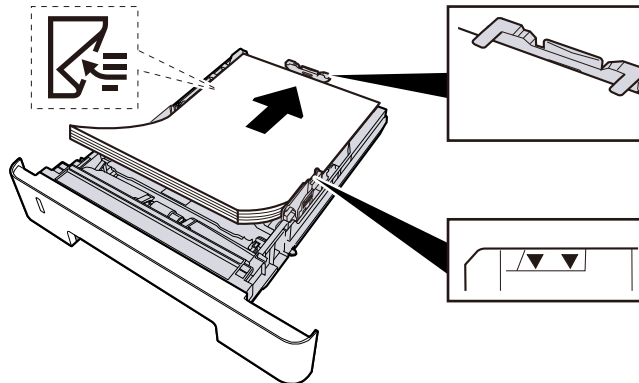

✔ IMPORTANT

- Load the paper with the print side facing down.
 - After removing new paper from its packaging, fan out the paper before loading it in the cassettes.
 - ➔ [Precaution for Loading Paper \(page 131\)](#)
 - Before loading the paper, be sure that it is not curled or folded. Paper that is curled or folded may cause paper jams.
 - Ensure that the loaded paper does not exceed the level indicator.
 - If paper is loaded without adjusting the paper length guide and paper width guide, the paper may skew or become jammed.
-

4 Gently push the cassette back in.

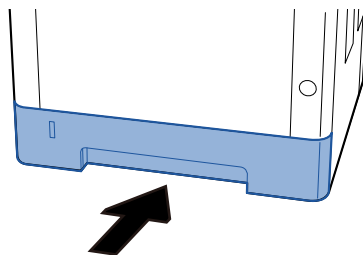

IMPORTANT

Push all cassettes all the way in. If they are not pushed all the way in, they may cause a jam.

NOTE

There is a paper gauge on the right side of the front of the cassette. The display changes up and down to match the remaining amount of paper.

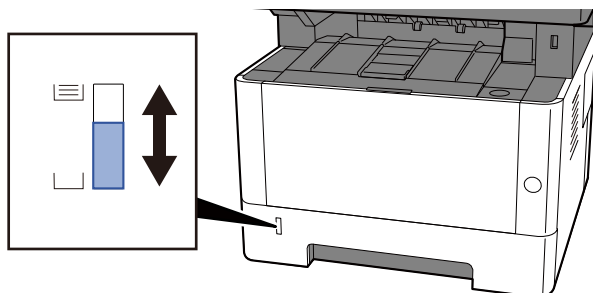

5 Specify the type of paper loaded in the cassette using the operation panel.

➔ [Loading in the Cassettes \(page 133\)](#)

Paper Specifications available in the Multipurpose Tray

Up to 100 sheets of Plain paper (80 g/m²) can be added to the multipurpose tray.

For details of the supported paper sizes, refer to the following:

➔ [Choosing the Appropriate Paper \(page 770\)](#)

For the paper type setting, refer to the following:

➔ [\[Media Type Set.\] \(page 430\)](#)

Be sure to use the multipurpose tray when you print on any special paper.

IMPORTANT

If you are using a paper weight of 106 g/m² or more, set the media type to Thick and set the weight of the paper you are using.

The capacity of the multipurpose tray is as follows.

- Plain paper (80 g/m²): 100 sheets
 - Thick paper (209 g/m²): 5 sheets
 - Thick paper (157 g/m²): 5 sheets
 - Thick paper (104.7 g/m²): 70 sheets
 - Hagaki (Cardstock): 15 sheets
 - Envelope DL, Envelope C5, Envelope #10, Envelope #9, Envelope #6 3/4, Envelope Monarch, Youkei 4, Youkei 2: 55 sheets
 - Transparencies: 1 sheets
-

NOTE

- When you load custom size paper, enter the paper size by referring to the following:
 - ➔ [Paper Specifications available in the Multipurpose Tray \(page 137\)](#)
 - When using special paper such as transparency or thick paper, set the media type.
 - ➔ [\[Orig./Paper Set.\] \(page 432\)](#)
-

Loading Paper in the Multipurpose Tray

1 Open the multipurpose tray.

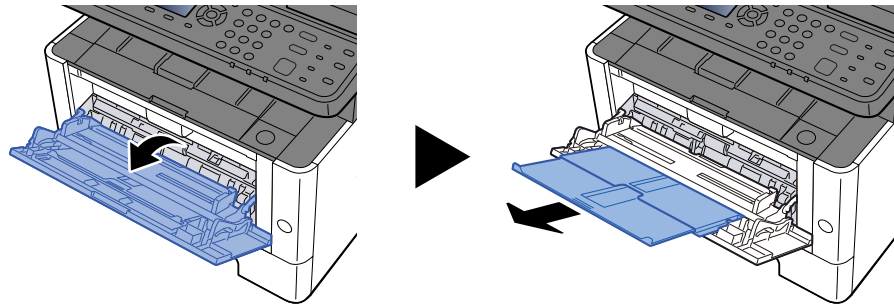

2 Adjust the multipurpose tray size.

Paper sizes are marked on the multipurpose tray.

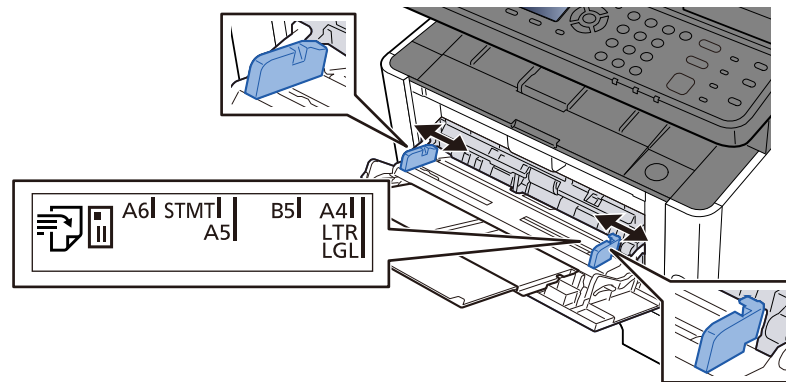

3 Load paper

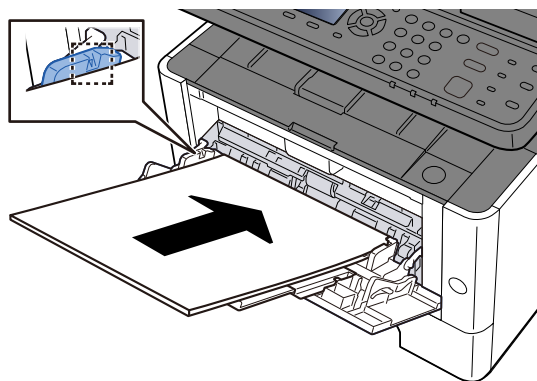

Insert the paper along the paper width guides into the tray until it stops.

After removing new paper from its packaging, fan the paper before loading it in the multipurpose tray.

➔ [Precaution for Loading Paper \(page 131\)](#)

✓ IMPORTANT

- When loading the paper, keep the print side facing up.
- Curled paper must be uncurled before use.
- When loading paper into the multipurpose tray, check that there is no paper left over in the tray from a previous job before loading the paper. If there is just a small amount of paper left over in

the multipurpose tray and you want to add more, first remove the left-over paper from the tray and include it with the new paper before loading the paper back into the tray.

- If there is a gap between the paper and the paper width guides, readjust the guides to fit the paper in order to prevent skewed feeding and paper jams.
 - Ensure that the loaded paper does not exceed the load limits.
-

When you load envelopes or cardstock in the multipurpose tray, load the paper with the print side facing up. For the procedure for printing, refer to the Printer Driver User Guide.

➔ **Printer Driver User Guide**

Example: When printing the address.

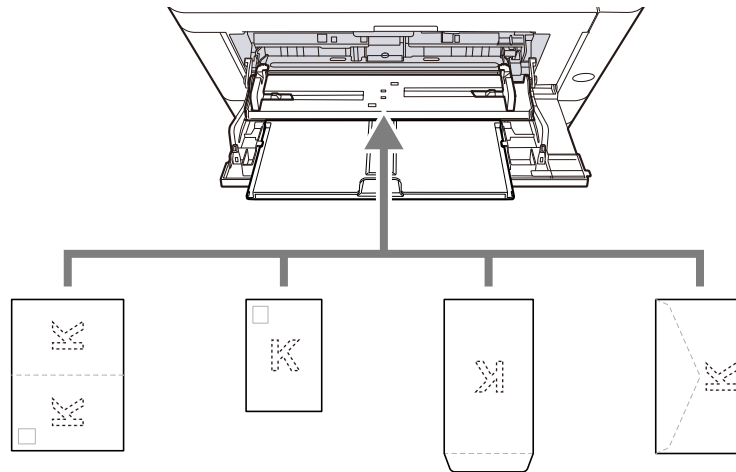

- Oufuku hagaki (Return postcard)
 - Hagaki (Cardstock)
 - Vertical envelope (open opening)
 - Horizontal envelope (close opening)
-

✔ **IMPORTANT**

- Use unfolded Oufuku hagaki (Return postcard).
 - How to load envelopes (orientation and facing) will differ depending on the type of envelope. Be sure to load it in correctly, otherwise printing may be done in the wrong direction or on the wrong face.
-

💡 **NOTE**

When you load envelopes in the multipurpose tray, select the envelope type by referring to the following:

➔ [\[MF Tray Set.\] \(page 435\)](#)

4 Specify the type of paper loaded in the multipurpose tray using the operation panel.

➔ [Specifying Paper Size and Media Type \(page 140\)](#)

Specifying Paper Size and Media Type

The default paper size setting for cassette 1, for the multipurpose tray and for the optional paper feeder (cassettes 2 to 3) is "A4", and the default media type setting is "Plain". To change the type of paper to be used in cassettes, specify the paper size and media type.

1 Display the screen

- [System Menu/Counter] key > [▲][▼] keys > [Common Settings] > [▲][▼] keys > [Orig./Paper Set.] > [▲][▼] keys > Select a cassette

2 Select the cassette size and type

Cassette Paper Size and Media Type

Set the size of paper and Media type used in cassettes.

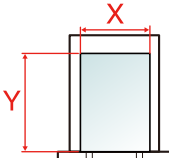
Item	Description
[Paper SizePaper Size]	<p>Select the paper size.</p> <p>Value (Cassette 1 to 3)</p> <p>[A4], [A5-R], [A5], [A6], [B5], [B6], [Folio], [216 x 340 mm], [Letter], [Legal], [Statement-R], [Executive], [OfficioII], [16K], [ISO B5], [Custom]</p> <p>For custom paper size, set the size for each cassette.</p> <p>➔ Custom PaperSize (page 433)</p> <p style="text-align: center;">Vertical</p> 
[Media Type]	<p>Value (Cassette 1 to 3)</p> <p>[Plain], [Recycled], [Preprinted], [Bond], [Color], [Prepunched], [Letterhead], [Thick], [High Quality], [Custom 1] to [Custom 8]</p> <ul style="list-style-type: none"> To change to a media type other than "Plain," refer to the following. <ul style="list-style-type: none"> ➔ [Media Type Set.] (page 430) When a paper weight that cannot be loaded in the cassette is set for a media type, that media type does not appear. To print on preprinted or prepunched paper or on letterhead, refer to the following:

Multipurpose Tray Paper Size and Media Type

Set the size of paper and media type used in the multipurpose tray.

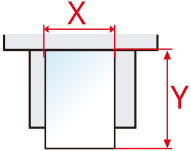
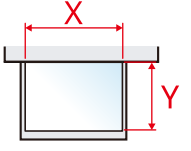
Item	Description
[Paper Size]	<p>Select the paper size.</p> <p>Value: [A4], [A5-R], [A5], [A6], [B5], [B6], [Folio], [216 x 340 mm], [Letter], [Legal], [Statement], [Executive], [OfficioII], [16K], [ISO B5], [Envelope #10], [Envelope #9], [Envelope #6], [Envelope Monarch], [Envelope DL], [Envelope C5], [Cardstock], [Ofuku], [Youkei 4], [Youkei 2], [Custom]</p> <p>For custom paper size, set the size for each cassette.</p> <p>➔ Custom PaperSize (page 433)</p> <div style="display: flex; justify-content: space-around; align-items: center;"> <div style="text-align: center;"> <p>Vertical</p>  </div> <div style="text-align: center;"> <p>Horizontal</p>  </div> </div>
[Media Type]	<p>Select the media type.</p> <p>Value: [Plain], [Labels], [Recycled], [Preprinted], [Bond], [Cardstock], [Color], [Prepunched], [Letterhead], [Envelope], [Thick], [High Quality], [Custom 1] to [Custom 8]</p> <p>To change to a media type other than "Plain," refer to the following.</p> <p>➔ [Media Type Set.] (page 430)</p> <p>To print on preprinted or prepunched paper or on letterhead, refer to the following:</p>

NOTE

The available media types for printing received faxes are as shown below.

Value: [Plain], [Labels], [Recycled], [Vellum], [Bond], [Color], [Envelope], [Cardstock], [Coated][Thick], [High Quality], [Custom 1] to [Custom 8]

Fax function is available for fax models.

Paper Stopper

When using paper A4/Letter or larger, open the paper stopper shown in the figure.

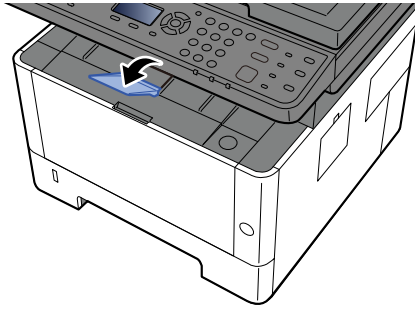

Preparation for Sending a Document to a Shared Folder in a PC

Check the information that needs to be set on the machine and create a folder to receive the document on your computer. Screens of Windows 10 are used in the following explanation. The details of the screens will vary in other versions of Windows.

NOTE

Log on to Windows with administrator privileges.

Make a note of the computer name and full computer name

Check the name of the computer name and full computer name.

1 Display the screen

Select the Windows [Start] button → [Windows System] → [Control Panel] → [System], in that order.

NOTE

For Windows 11, select the Windows [Start] button → [All apps] → [Settings] → [System] → [About] → [Advanced system settings], in that order.

2 Check the information.

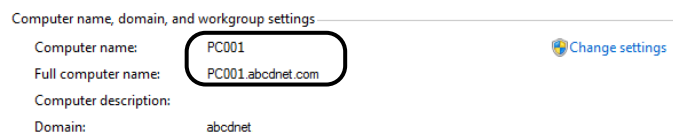

Check the computer name and full computer name.

Screen example:

Computer name: PC4050

Full computer name: pc4050.abcdnet.com

After checking the computer name, click the  [Close] button to close the "System" screen.

Make a note of the user name and domain name

Check the domain name and user name for logging onto Windows.

1 Display the screen

Select the Windows [Start] button → [Windows System] → [Command Prompt], in that order.



NOTE

For Windows 11, select the Windows [Start] button → [All apps] → [Windows Tools] → [Command Prompt], in that order.

The Command Prompt window appears.

2 Check the domain name and user name.

At the Command Prompt, enter "net config workstation" and then press [Enter].

```
Microsoft Windows [Version 10.0.15063]
(c) 2017 Microsoft Corporation. All rights reserved.

C:\Users\PC0270>net config workstation
Computer name                PC0270
Full Computer name          PC0270
User name                    PC0270

Workstation active on
NetBI_Tcpip_{FABABC9C-741F-40DF-B0ED-BD92F1900FE6} (00252261F4D8)

Software version             Windows 10 Pro
Workstation domain           PC0270
Logon domain                  PC0270

COM Open Timeout (sec)      0
COM Send Count (byte)       16
COM Send Timeout (msec)     250
The command completed successfully.

C:\Users\PC0270>
```

Check the user name and domain name.

Screen example:

User Name: yamada

Domain Name: ABCDNET

Create a shared folder and make a note of the shared folder name

Create a shared folder to receive the document in the destination computer.

NOTE

If there is a workgroup in System Properties, configure the settings below to limit folder access to a specific user or group.

- 1 For Windows 10, open up a window in File Explorer and select [View] → [Options] → [Folder Options], in that order.

For Windows 11, open up a window in File Explorer and select [...] → [Options], in that order.

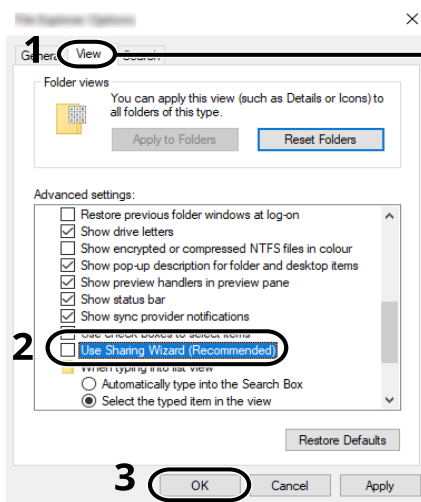

Make sure that the [View] tab is selected.

- 2 Uncheck [Use Sharing Wizard (Recommended)] in "Advanced setting".
- 3 Click [OK].

1 Create a folder.

Create a folder on your computer. For example, create a folder with the name "scannerdata" on the desktop.

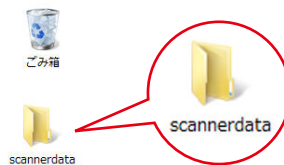

2 Configure permission settings.

- 1 Right-click the "scannerdata" folder, click [Properties]→ [Sharing] tab, → [Advanced Sharing], in that order.

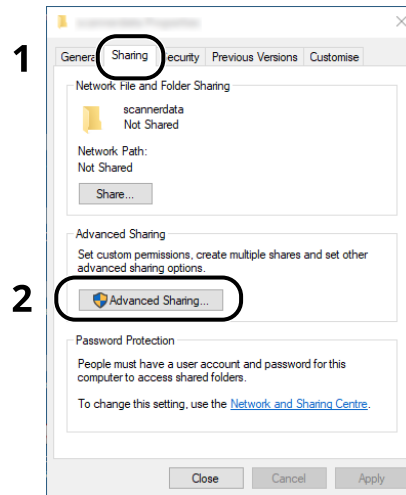

- 2 Select the [Share this folder] checkbox, and then click the [Permissions] button.

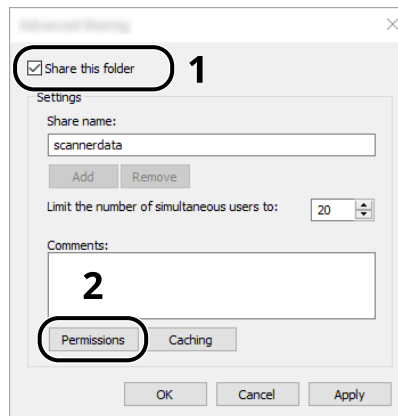

- 3 Make a note of the Share name.

- 4 Click the [Add] button.

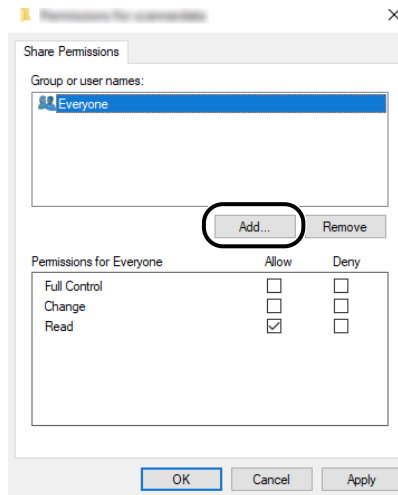

- 5 Specify the location.

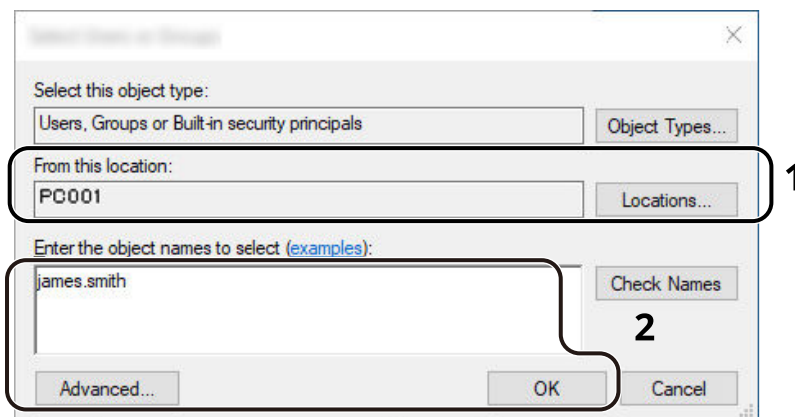

- 1 If the computer name that you made a note is the same as the domain name:
 If the computer name is not shown in "From this location", click the [Location] button, select the computer name, and click the [OK] button.
 Example) pc4050
 If the computer name that you made a note is not the same as the domain name:
 If the text after the first dot (.) in the full computer name that you made a note of does not appear in the "Location", click the [Location] button, select the text after the dot (.), and click the [OK] button.
 Example: abcdnet.com
 ➔ [Make a note of the computer name and full computer name \(page 143\)](#)
- 2 Enter the user name that you made a note of on page in the text box, and click the [OK] button.
 Also the user name can be made by clicking the [Advanced] button and selecting a user.

- 6 Set the access permission for the user selected.

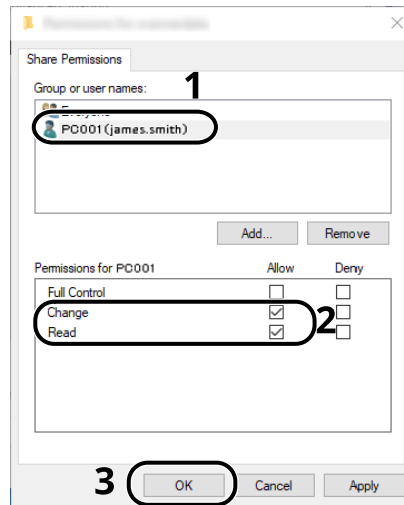

- 1 Select the user you entered.
- 2 Select "Change" checkbox of "Read" and [Change].
- 3 Click the [OK] button.

 **NOTE**

"Everyone" gives sharing permission to everyone on the network. To strengthen security, it is recommended that you select "Everyone" and remove the checkmark of [Allow] of "Read".

- 7 Click the [OK] button in the "Advanced Sharing" screen to close the screen.

8 Check the details set in the [Security] tab.

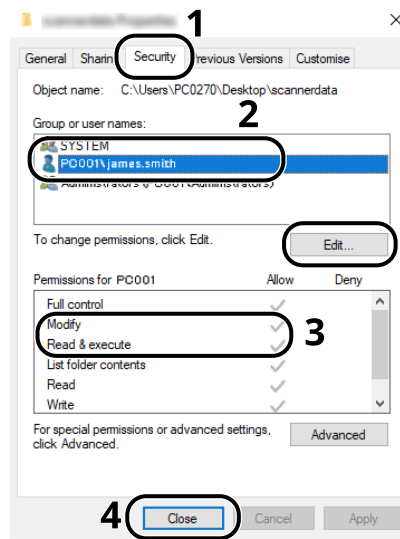

1 Select the [Security] tab.

2 Select the user you entered.

If the user does not appear on "Group or user names", click [Edit] button to add user in a similar way of "configuration of permission settings".

3 Make sure that checkmarks appear on the [Allow] checkbox for "Modify" and "Read & execute".

4 Click the [Close] button.

Configuring Windows Firewall

Permit sharing of files and printers and set the port used for SMB transmission.

NOTE

Log on to Windows with administrator privileges.

1 Check file and printer sharing.

- 1 Select the Windows [Start] button → [Windows System] → [Control Panel] → [System] → [Allow an app through Windows Firewall], in that order.

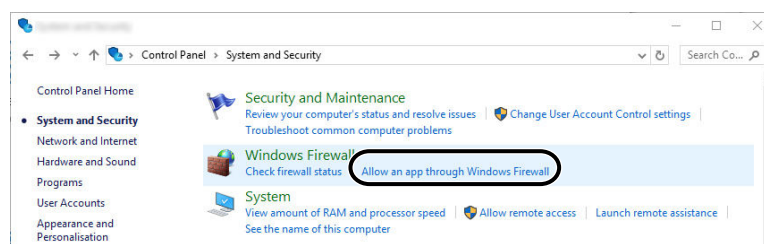

NOTE

- For Windows 11, select the Windows [Start] button →→ [All apps] → [Windows Tools] → [Control Panel] → [System] → [Allow an app through Windows Firewall], in that order.
- If the User Account Control dialog box appears, click the [OK] button.

- 2 Select the [File and printer sharing] checkbox.

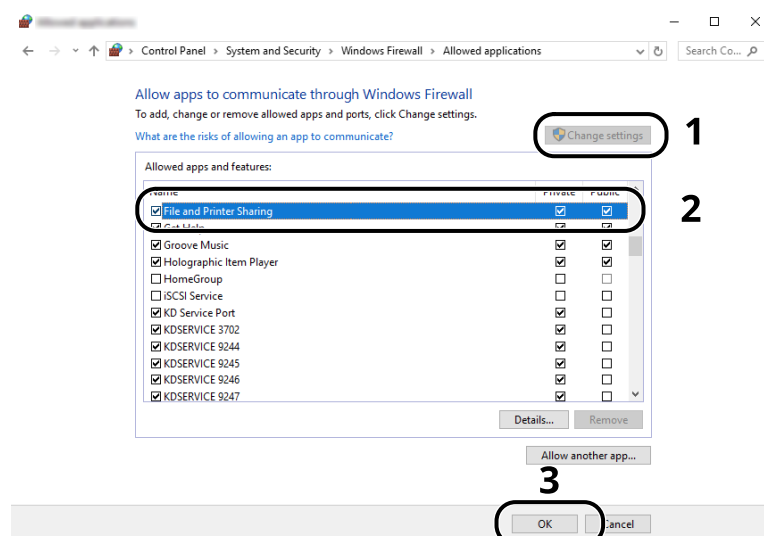

2 Add a port.

- 1 Please select the Windows [Start] button → [Windows System Tools] → [Control Panel] → [System and Security] → [Check Firewall Status], in that order.

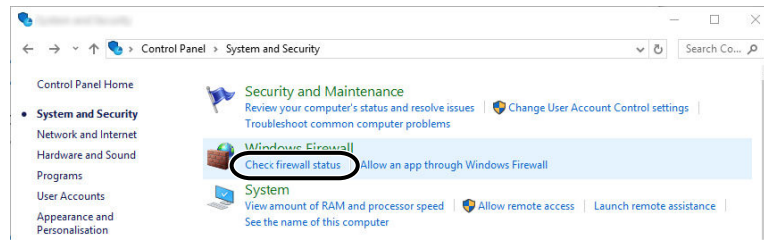

- 2 Click [Advanced settings].

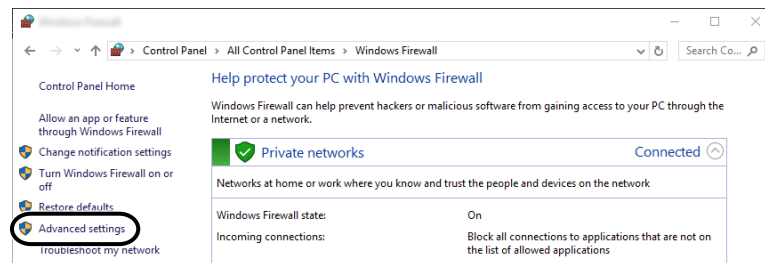

- 3 Click [Inbound Rules].

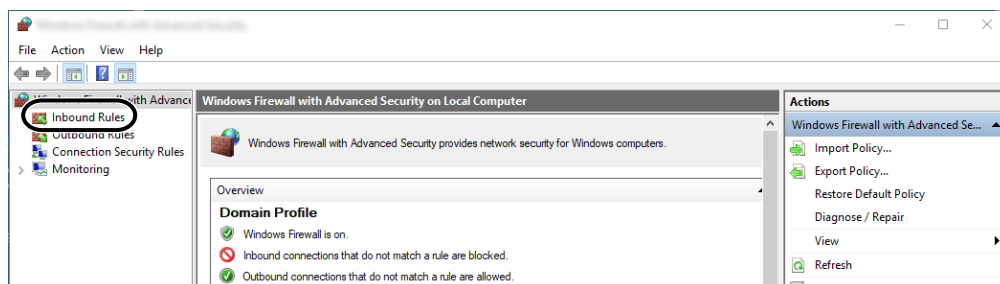

- 4 Click [New Rule].

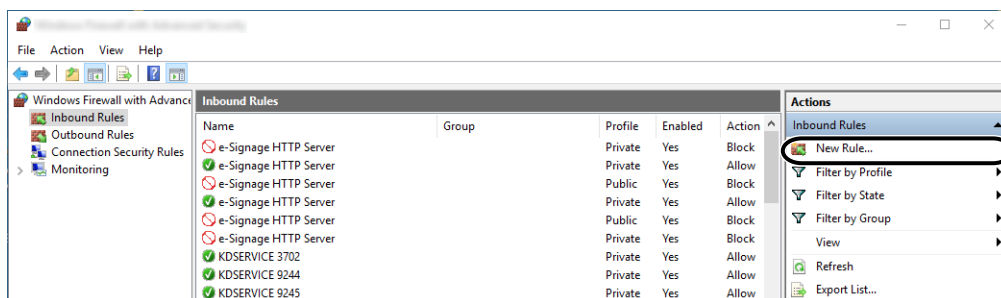

5 Select [Port] from the rule.

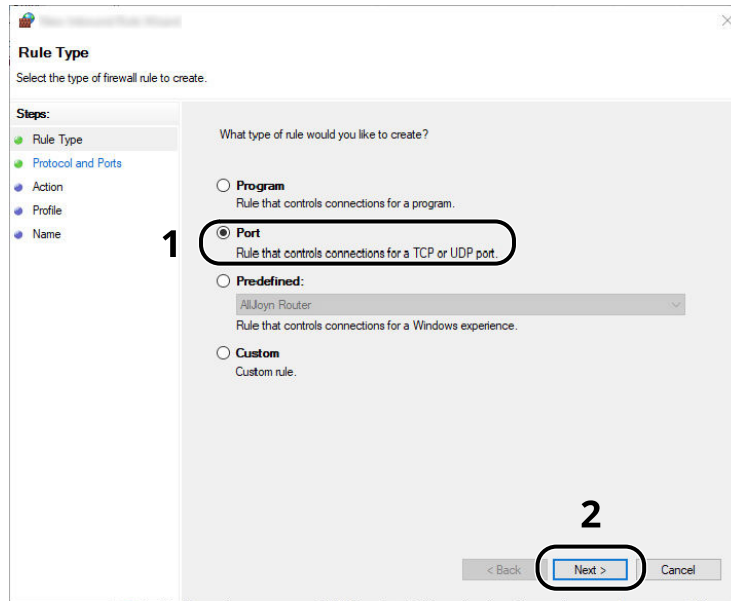

6 Select [TCP] as the port to apply the rule to. Then select [Specific local ports] and enter "445" then click [Next].

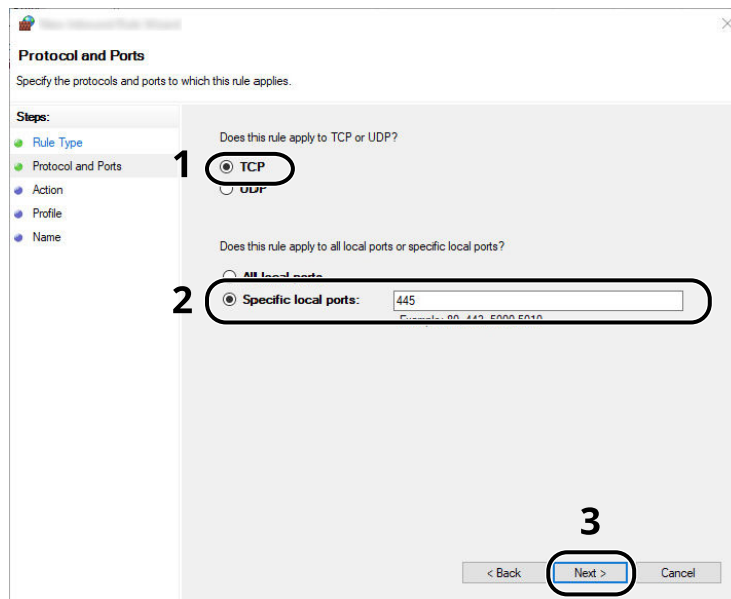

7 Select [Allow the connection] and click [Next].

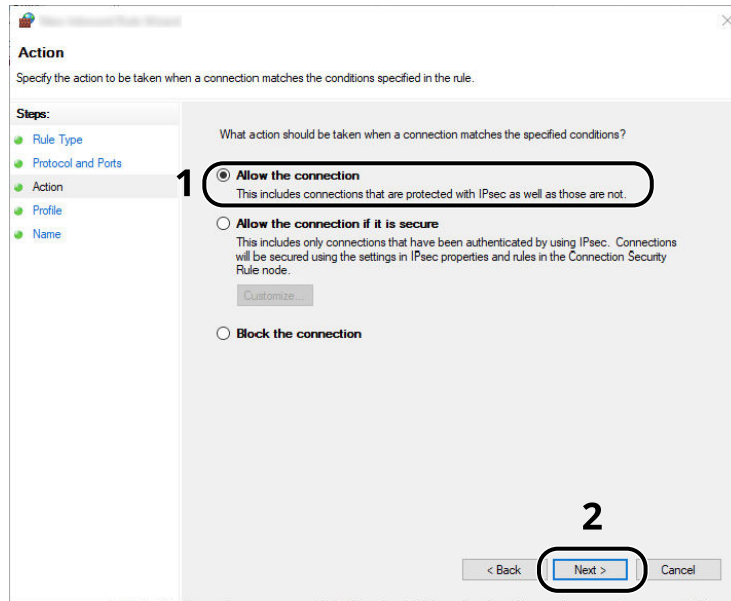

8 Make sure all checkboxes are selected and click the [Next] button.

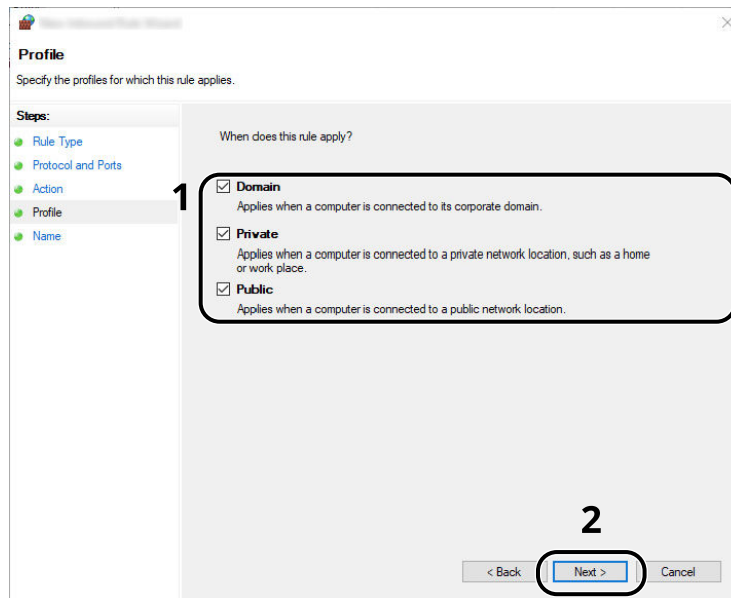

- 9 Enter "Scan to SMB" in [Name] and click [Finish].

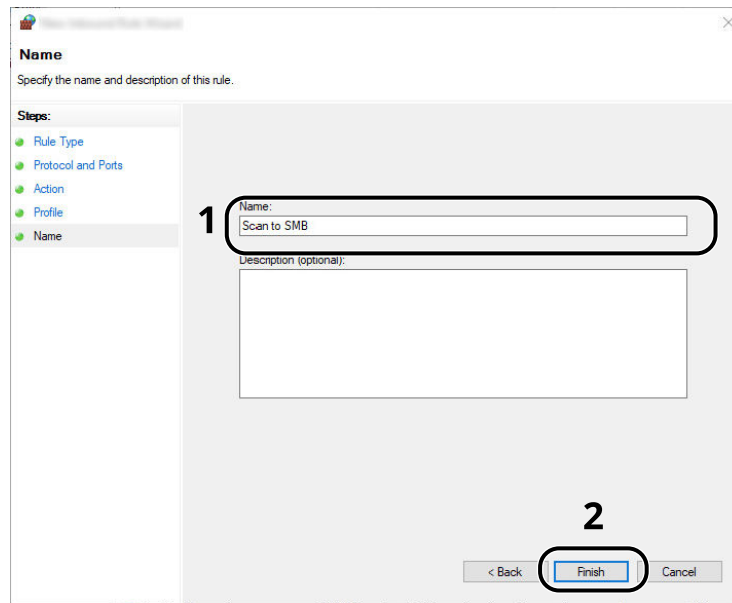

Scan to Folder Setup Tool for SMB

An environment for sending a document to Windows can be set up smoothly by using the Scan to Folder Setup Tool for SMB downloaded from Download Center (<https://kyocera.info/>).

By operating the Scan to Folder Setup Tool for SMB, you can configure the following settings.

- Create a shared folder in a PC for receiving documents:

A new folder can be easily created on the desktop. Also, the newly created folder is automatically set as a shared folder.

- Set the created shared folder as an address on this machine:

Information about such things as the name of the computer and shared names for the shared folder is easily recorded in the address book of this machine with a sequence of actions. Can also be registered on the One Touch Keys.

NOTE

- Log on to Windows with administrator privileges.
- If user login administration is enabled, log in with administrator privileges or as a user with execution authority.

1 Download a software from the website.

- 1 Launch your Web browser.
- 2 Enter "<https://kyocera.info/>" to the browser's address bar or location bar.



- 3 Enter and search the product name, and select this product from the candidate list.

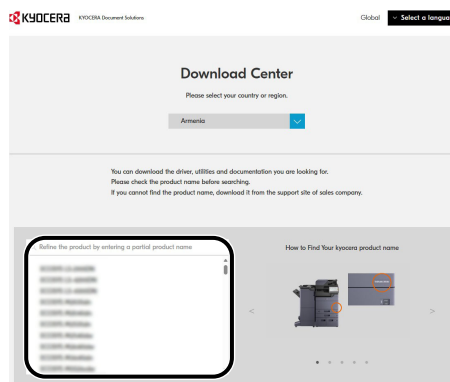

- 4 Follow the guidance on the screen to download the Scan to Folder Setup Tool.

- 5 Change the selected operating system and its language setting as needed.

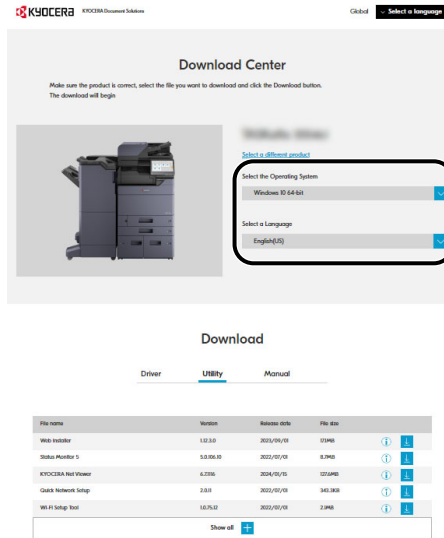

- 6 "Utility" >  in "Scan to Folder Setup Tool for SMB"

The Scan to Folder Setup Tool for SMB will be downloaded.

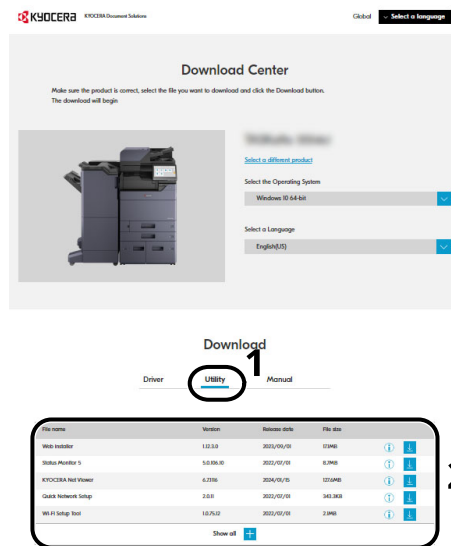

- 7 Double-click the downloaded installer to launch.

2 Configure the settings

- 1 Select the device to use and click [Next].

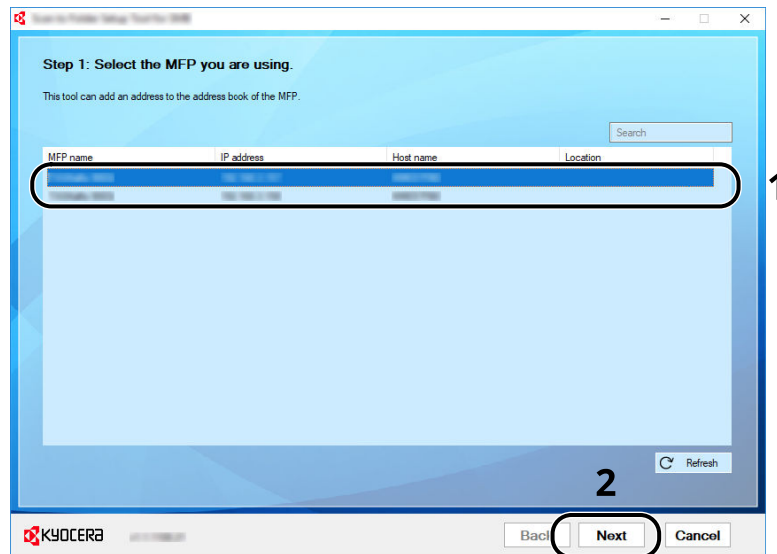

NOTE

- The machine cannot be detected unless it is on. If the computer fails to detect the machine, verify that it is connected to the computer via a network cable and that it is turned on and click  [Refresh].
- If user administration is valid on this machine, the user authentication screen appears. Log in with administrator privileges or as a user with execution authority.

The address book of the device appears.

2 Click [Add].

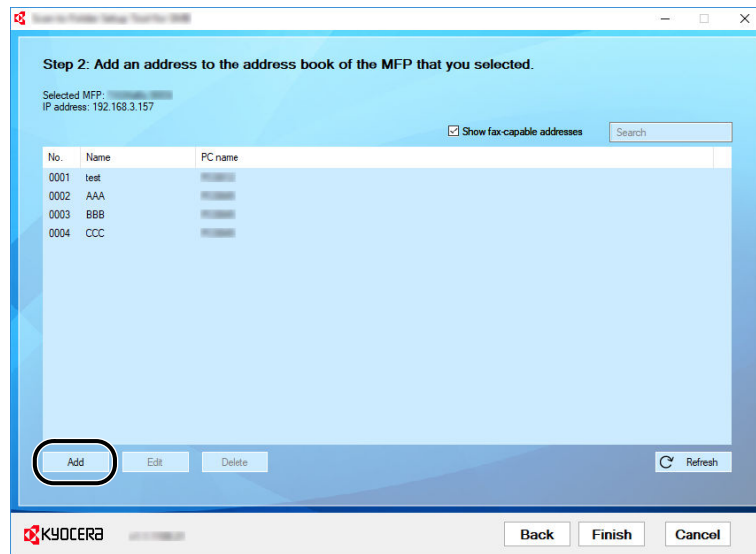
 **NOTE**

- Clicking on [Edit] after selecting the registered address allows you to change the content of the registration.
- Unchecking the [Show fax-capable addresses] check-box will hide the address containing the fax.

3 Create a new folder.

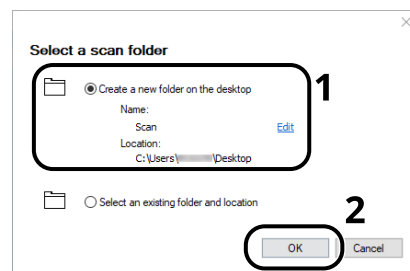

Select "Creat a new folder on the desktop" and click [OK] to create a new folder on the desktop. (The default folder name is "Scan".)

 **NOTE**

- Click [Edit] to change the desktop folder name.
- Selecting [Select an existing folder and location] allows you to select an existing folder that is already set as a shared folder on the PC.

- 4 Enter the information requested to register the address.

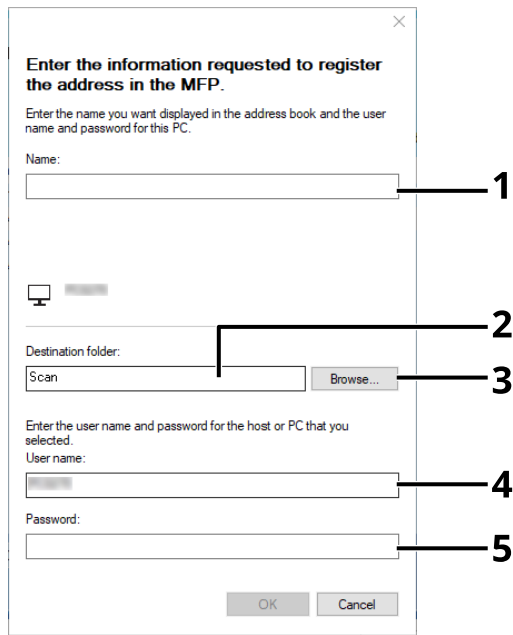

- 1 Enter the name for display in the address book.
 - 2 Display the folder name and path to the shared folder.
 - 3 Shared folders can be selected from a PC on the network.
 - 4 Display the user name of the selected PC.
 - 5 Enter the password corresponds to the log in user name of the selected PC.
- 5 Click [OK] to register the address to the address book.
 - 6 Click [Close].
 - 7 To register the registered address in a One Touch key, click [Yes].

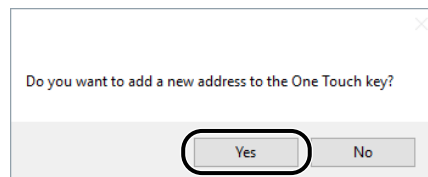

- 8 Select a One Touch Key with no registered destination, and click [Submit].

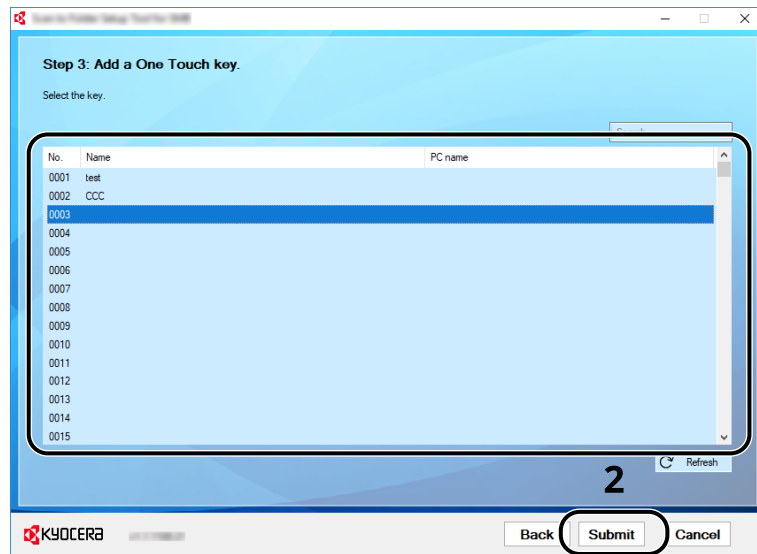

- 9 Click [Close].
- 10 Click [Finish] to exit the Scan to Folder Setup Tool for SMB.

Registering Destinations in the Address Book

Save frequently used destinations to the Address Book or One Touch Keys. The saved destinations can be changed. The destinations are available for Send as E-mail, Send to Folder, and Fax Transmission (Only on products with the fax function installed).

NOTE

- Registering and editing of the Address Book can also be done in Command Center RX.
 - ➔ [Registering Destinations \(page 120\)](#)
 - Editing of the Address Book and One Touch Keys can be restricted to administrators.
 - ➔ [Add One Touch Keys. \(page 172\)](#)
-

Adding a Destination (Address Book)

Add a new destination to the Address Book. There are two registering methods, contacts and groups. When adding a group, enter the group name and select group members from the Address Book.

NOTE

If registering and editing of the Address Book is restricted to administrators, you can edit the Address Book by logging in with administrator privileges.

- ➔ [Edit Restriction \(page 476\)](#)
 - ➔ [Command Center RX User Guide](#)
-

Registering an Address (E-mail Address)

The registering method of an E-mail address to Address Book is as follows.

1 Display the screen

[System Menu/Counter] key > [▲][▼] key > [Edit Destination] > [OK] key > [▲][▼] key > [Address Book] > [OK] key > [Menu] > [▲][▼] key > [Add Address] > [OK] key > [▲][▼] key > [Contacts] > [OK] key

2 Enter an address number.

To have the number assigned automatically, select [Auto] (000).

NOTE

- Address Number is an ID for a destination. You can select any available number out of 300 numbers for contacts and 50 numbers for groups.
 - If you specify an address number that is already in use, an error message appears when you select [Register] and the number cannot be registered. If you set [Auto] (000) as the address number, the address is registered under the lowest available number.
-

3 Add the name.

- 1 [◀][▶] keys > [Contact Name] > [Edit]
- 2 Enter the destination name for display in the address book and select the [OK] key.



NOTE

For details on entering characters, refer to the following:

➔ [Character Entry \(page 761\)](#)

4 Add the address.

- 1 [◀][▶] keys > [E-mail Address] > [Edit]
- 2 Enter the E-mail address and select the [OK] key.



NOTE

For details on entering characters, refer to the following:

➔ [Character Entry \(page 761\)](#)

5 Set an address number

- 1 [◀][▶] keys > [Address Number] > [Edit]
- 2 Enter an address number.

The number can be set between 1 and 350. Use the numeric keypad or select the [▲] or [▼] key and enter a number. Address Number is an ID for a destination. You can choose any available number. If you specify an address number that is already in use, an error message appears when you select the [OK] key and the number cannot be registered.

- 3 Select the [OK] key.

6 Check if the destination entry is correct and select the [OK] key.

The destination is added to the Address Book.



NOTE

Refer to the following for registering the One Touch Key.

➔ [Add One Touch Keys. \(page 172\)](#)

Registering an Address (Folder (SMB) Address)

The registering method of an folder (SMB) address to Address Book is as follows.

1 Display the screen

[System Menu/Counter] key > [▲][▼] keys > [Edit Destination] > [OK] key > [▲][▼] keys > [Address Book] > [OK] key > [Menu] key > [▲][▼] keys > [Add Address] > [OK] key > [▲][▼] keys > [Contacts] > [OK] key

2 Add the name.

1 [◀][▶] keys > [Contact Name] > [Edit]

2 Enter the destination name for display in the address book and select the [OK] key.



NOTE

For details on entering characters, refer to the following:

➔ [Character Entry \(page 761\)](#)

3 Add the address.

1 [◀][▶] keys > [Folder(SMB)] > [Edit]

2 To directly specify the SMB folder, enter "Host Name", "Path", "Login User Name", and "Login Password".

The table below explains the items to be entered.

"Host Name"

Computer name.

Enter "Host Name" or "IP Address". To enter the IPv6 address, enclose the IPv6 address in brackets [].

(Example: [2001:db8:a0b:12f0::10])

"Path"

Share name

For example: scannerdata

If saving in a folder in the shared folder:

share name\folder name in shared folder

"Login User Name"

- If the computer name and domain name are the same
User Name
For example: james.smith.
- If the computer name and domain name are different
Domain name\User name
For example: abcdnet\james.smith

"Login Password"

"Login Password" is the Windows logon password
(Case sensitive)



NOTE

- For details on entering characters, refer to the following:
➔ [Character Entry \(page 761\)](#)
-

4 Select [Yes] in the connection confirmation screen.

The connection will be verified. If you select [No], no confirmation will be made. [Connected.] appears when connection to the destination is correctly established. If [Cannot connect.] appears, review the entry.

5 Set an address number

1 [◀][▶] keys > [Address Number] > [Edit]

2 Enter an address number.

The number can be set between 1 and 350. Use the numeric keypad or select the [▲] or [▼] key and enter a number. Address Number is an ID for a destination. You can choose any available number. If you specify an address number that is already in use, an error message appears when you select the [OK] key and the number cannot be registered.

3 Select the [OK] key.

6 Check if the destination entry is correct and select the [OK] key.

The destination is added to the Address Book.

Registering an Address (Folder (FTP) Address)

The registering method of an folder (FTP) address to Address Book is as follows.

1 Display the screen

[System Menu/Counter] key > [▲][▼] keys > [Edit Destination] > [OK] key > [▲][▼] keys > [Address Book] > [OK] key > [Menu] key > [▲][▼] keys > [Add Address] > [OK] key > [▲][▼] keys > [Contacts] > [OK] key

2 Add the name.

1 [◀][▶] keys > [Contact Name] > [Edit]

2 Enter the destination name for display in the address book and select the [OK] key.



NOTE

For details on entering characters, refer to the following:

➔ [Character Entry \(page 761\)](#)

3 Add the address.

1 [◀][▶] keys > [Folder(FTP)] > [Edit]

2 To directly specify the FTP folder, enter "Host Name", "Path", "Login User Name", and "Login Password".

The table below explains the items to be entered.

"Host Name"

Host name or IP address of FTP server

To enter the IPv6 address, enclose the IPv6 address in brackets [].

(Example: [2001:db8:a0b:12f0::10])

"Path"

Path for the file to be stored.

For example) ¥User¥scandata

If no path is entered, the file is stored in the home directory.

When the FTP server is based on Linux/UNIX, the path including the sub-folder is combined by the slash "/" not using the back-slash.

"Login User Name"

FTP server login user name

"Login Password"

FTP server login password



NOTE

For details on entering characters, refer to the following:

➔ [Character Entry \(page 761\)](#)

4 Select [Yes] in the connection confirmation screen.

The connection will be verified. If you select [No], no confirmation will be made. "Connected. " appears when connection to the destination is correctly established. If "Cannot connect. " appears, review the entry.

When [SSL] in [Secure Settings] is enabled, is displayed after "Yes" is selected. Select "Yes" to check the connection for FTP encrypted communication. Select "No" to return to the normal connection confirmation screen.

"Connected. " appears when connection to the destination is correctly established. If "Cannot connect. " appears, review the entry.

5 Set an address number

1 [◀][▶] keys > [Address Number] > [Edit]

2 Enter an address number.

The number can be set between 1 and 350. Use the numeric keypad or select the [▲] or [▼] key and enter a number. Address Number is an ID for a destination. You can choose any available number. If you specify an address number that is already in use, an error message appears when you select the [OK] key and the number cannot be registered.

3 Select the [OK] key.

6 Check if the destination entry is correct and select the [OK] key.

The destination is added to the Address Book.

Add the group

Compile two or more contacts into a group. Designations in the group can be added at the same time. When adding a group, a maximum of 5050 groups can be added in the Address Book.

NOTE

To add a group, you need individually added destinations. Register one or more individual destinations as needed before proceeding. Up to 100 destinations for the E-mail, FAX, and a total of 5 destinations for the FTP and SMB can be registered per group.

1 Display the screen

[System Menu/Counter] key > [▲] [▼] keys > [Edit Destination] > [OK] key > [▲] [▼] keys > [Address Book] > [OK] key > [Menu] > [▲] [▼] keys > [Add Address] > [OK] key > [▲] [▼] keys > [Group] > [OK] key

2 Add the name.

1 [◀] [▶] keys > [Group Name] > [Edit]

2 Enter the group name displayed on the Address Book and select the [OK] key.

NOTE

For details on entering characters, refer to the following:

➔ [Character Entry \(page 761\)](#)

3 Select the members (destinations).

1 [◀] [▶] keys > [Group Member] > [Edit] > [Menu] > [▲] [▼] keys > [Add Destination] > [OK] key >

2 Select the group you want to add to and select [OK] key.

NOTE

You can search by name by selecting [Menu][Search(Furigana)].

3 Select the destination you want to register as a group from the registered individual destinations, and select the key [OK].

The selected destination will be added to the group. To add the destination, repeat steps 3-1 to 3-3.

4 Select the [Back] key.

4 Set an address number

1 [◀] [▶] keys > [Address Number] > [Edit]

2 Enter an address number.

The number can be set between 1 and 350. Use the numeric keypad or select the [▲] or [▼] key and enter a number. Address Number is an ID for a destination. You can choose any available number. If you specify an address number that is already in use, an error message appears when you select the [OK] key and the number cannot be registered.

3 Select the [OK] key.

5 Select the [OK] key.

The group is added to the Address Book.

Editing Contact Address in Address Book

Edit the destinations (contacts) you added to the Address Book.

1 Display the screen

- 1 [System Menu/Counter] key > [▲][▼] keys > [Edit Destination] > [OK] key > [▲][▼] keys > [Address Book] > [OK] key

2 Edit a contact address.

- 1 Select the destination [Contacts] to edit and select the key.
- 2 Change [Contact Name], [Furigana], destination type, address, and [Address Number]. For how to change, refer to the following:
➔ [Registering an Address \(E-mail Address\) \(page 161\)](#)
- 3 After making changes, press the key >"Yes"
Register the changed destination.

Editing Group Address in Address Book

Edit the destinations (group address) you added to the Address Book.

1 Display the screen

- 1 [System Menu/Counter] key > [▲][▼] keys > [Edit Destination] > [OK] key > [▲][▼] keys > [Address Book] > [OK] key

2 Edit a destination to a group.

- 1 Select the group you wish to edit and select the key.
- 2 Change [Group Name], [Furigana], and [Address Number]. For how to change, refer to the following:
➔ [Add the group \(page 167\)](#)
- 3 [◀][▶] keys > [Group Member] > [Edit]
- 4 After making changes, press the key > [Yes]
Register the changed destination.
- 5 If you want to remove a member from a group, select the destination > [Menu] > [▲][▼] keys > [Delete] > key



NOTE

Select the destination and the key shows the detailed information of the selected destination.

To add the destination, select [Add Destination].

For how to change, refer to the following:

➔ [Add the group \(page 167\)](#)

- 6 Select [Yes].
- 7 After making changes, press the key > [Yes]
Register the changed destination.

Deleting Address Book Entries

Delete the destinations (contacts) you added to the Address Book.

1 Display the screen

- 1 [System Menu/Counter] key > [▲][▼] keys > [Edit Destination] > [OK] key > [▲][▼] keys > [Address Book] > [OK] key

2 Select a destination (individual) or group to delete, [Menu] > [▲][▼] keys > [Delete] > [OK] key > [Yes]

Add One Touch Keys.

Assign a new destination (contact or group) to an one touch key.

NOTE

- When the Shift Lock light is off, the one-touch keys are numbered 1 to 11. If the shift lock light is on when you select a key, the one touch keys are numbered 12 to 22.[Shift lock]
 - Refer to the following for use of One Touch Key.
 - ➔ [Choosing from One Touch key destinations \(page 254\)](#)
 - You can add One Touch Keys and edit their settings on Command Center RX.
 - ➔ **Command Center RX User Guide**
 - If registering and editing of the One Touch Keys is restricted to administrators, you can edit the One Touch Keys by logging in with administrator privileges.
 - ➔ **Command Center RX User Guide**
-

1 Select the one touch key to register

- 1 On the send screen or fax screen, press and hold the one-touch key you want to register. (2.0 seconds or more)
- 2 [▲][▼] keys > [Key number] > [OK] key

2 Select the destinations.

- 1 Select the destination you want to register to the one-touch key from among the destinations registered in the address book, and then select the key.
- 2 The destination will be added to the One Touch Key.

Editing the Destination to the One Touch Key

1 Select the one touch key you want to change

- 1 On the send screen or fax screen, press and hold the one-touch key you want to register. (2.0 seconds or more)
- 2 [▲][▼] keys > [Key number] > [OK] key

Select an unregistered One Touch Key number to display the address book. You can register by selecting a destination from the address book.

2 Edit a contact address.

- 1 [▲][▼] keys > [Edit] > [OK] key



NOTE

Selecting [Detail] and the [OK] key shows the detailed information of the selected destination.

- 2 Specify the destination and the [OK] key > [Yes]
Register the changed destination.

Deleting the Destination to the One Touch Key

1 Select a One Touch Key number to delete.

1 On the send screen or fax screen, press and hold the one-touch key you want to register. (2.0 seconds or more)

2 [▲][▼] keys > [Key number] > [OK] key

Select an unregistered One Touch Key number to display the address book. You can register by selecting a destination from the address book.

2 Delete destination

1 [▲][▼] keys > [Delete] > [OK] key > [Yes]

The data registered in the One Touch Key is deleted.

4 Print from PC

Printer Driver Print Settings Screen

The printer driver print settings screen allows you to configure a variety of print-related settings.

➔ Printer Driver User Guide

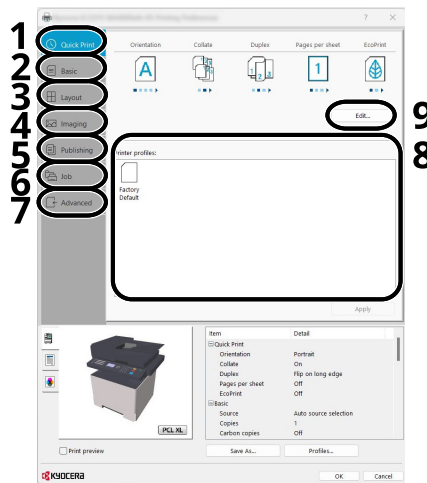

1 [Quick Print] tab

Provides icons that can be used to easily configure frequently used functions. Each time you click an icon, it changes to an image resembling the print results and applies the settings.



2 [Basic] tab

This tab groups basic functions that are frequently used. You can use it to configure the paper size, destination, and duplex printing.

3 [Layout] tab

This tab lets you configure settings for printing various layouts, including booklet printing, combine mode, poster printing, and scaling.

4 [Imaging] tab

This tab lets you configure settings related to the quality of the print results.

5 [Publishing] tab

This tab lets you create covers and inserts for print jobs and put inserts between sheets of OHP film.

6 [Job] tab

This tab lets you configure settings for saving print data from the computer to the machine. Regularly used documents and other data can be saved to the machine for easy printing later. Since saved documents can be printed directly from the machine, this function is also convenient when you wish to print a document that you don't want others to see.

7 [Advanced] tab

This tab lets you configure settings for adding text pages or watermarks to print data.

8 [Profiles]

Printer driver settings can be saved as a profile. Saved profiles can be recalled at any time, so it's a convenient practice to save frequently used settings.

9 [Factory Default]

Click to revert settings to their initial values.

Displaying the Printer Driver Help

The printer driver includes Help. To learn about print settings, open the printer driver print settings screen and display Help as explained below.

1 Click the [?] button.

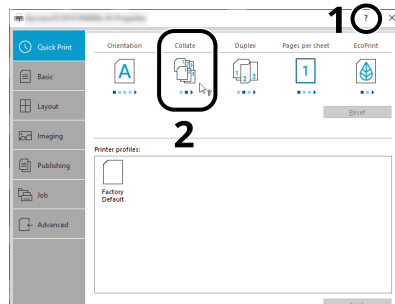

2 Click the item you want to know about.

NOTE

The Help appears, even when you click the item you want to know about and press the [F1] key on your keyboard.

Changing the Default Printer Driver Settings (Windows 2016 and later)

The default printer driver settings can be changed. By selecting frequently used settings, you can omit steps when printing. For the settings, refer to the following:

→ Printer Driver User Guide

- 1** Click the Windows [Start] button → [Windows System] → [Control Panel] → [Devices and Printer].
- 2** Right-click the printer driver icon of the machine, and click the [Printer properties] menu of the printer driver.
- 3** Click the [Preference] button on the [General] tab.
- 4** Select the default settings and click the [OK] button.

Changing the Default Printer Driver Settings (Windows 11)

The default printer driver settings can be changed. By selecting frequently used settings, you can omit steps when printing. For the settings, refer to the following:

➔ Printer Driver User Guide

- 1** Click the Windows [Start] button → [All apps] → [Windows Tools] → [Control Panel] → [Devices and Printers].
- 2** Right-click the printer driver icon of the machine, and click the [Printer properties] menu of the printer driver.
- 3** Click the [Preference] button on the [General] tab.
- 4** Select the default settings and click the [OK] button.

Printing from PC

This section provides the printing method using the KX DRIVER.

NOTE

- To print the document from applications, install the printer driver downloaded from Download Center (<https://kyocera.info/>) on your computer.
- In some environments, the current settings are displayed at the bottom of the printer driver.

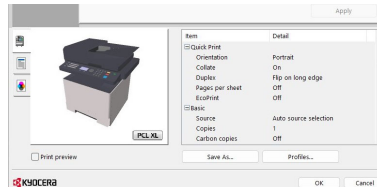

- When printing the cardstock or envelopes, load the cardstock or envelopes in the multipurpose tray before performing the following procedure.

➔ [Loading Paper in the Multipurpose Tray \(page 138\)](#)

Printing on Standard Sized Paper

If you loaded a paper size that is included in the print sizes of the machine, select the paper size in the [Preference] tab of the print settings screen of the printer driver.

NOTE

Specify the paper size and media type to print from the operation panel.

➔ [\[Orig./Paper Set.\] \(page 432\)](#)

1 Display the screen

Click [File] and select [Print].

2 Configure the settings

- 1 Select the machine from the "Printer" menu and click the [Properties] button.

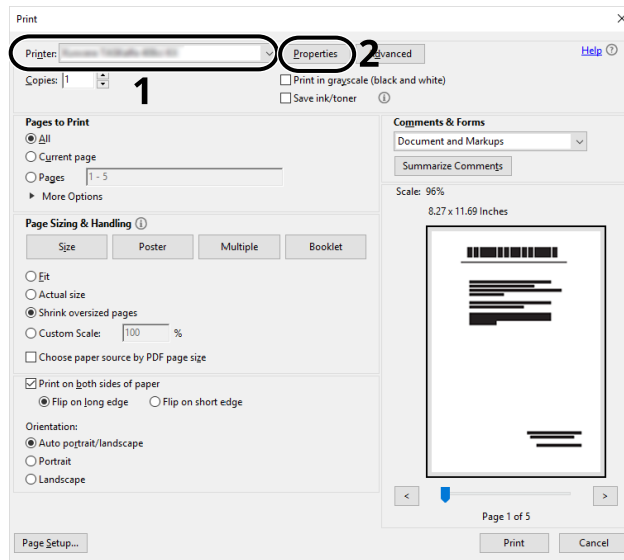

- 2 Select the [Preference] tab.

- 3 Click the "Print size" menu and select the paper size to use for printing.

To load the paper of size that is not included in print sizes of the machine such as cardstock or envelopes, the paper size needs to be registered.

➔ [Printing on Non-standard Sized Paper \(page 182\)](#)

To print on the special paper such as thick paper or transparency, click the "Media type" menu and select the media type.

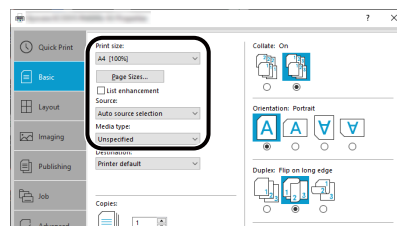

- 4 Click the [OK] button to return to the Print dialog box.

3 Start printing.

Click the [OK] button.

Printing on Non-standard Sized Paper

If you loaded a paper size that is not included in the print sizes of the machine, register the paper size in the [Preference] tab of the print settings screen of the printer driver.

The registered size can be selected from the "Print size" menu.

NOTE

Specify the paper size and media type to print from the operation panel.

→ [\[Orig./Paper Set.\] \(page 432\)](#)

1 Display the screen

- 1 Select the Windows [Start] button → [Windows System] → [Control Panel] → [Devices and Printers].
-

NOTE

For Windows 11, select the Windows [Start] button → [All apps] → [Windows Tools] → [Control Panel] → [Devices and Printers].

- 2 Right-click the printer driver icon of the machine, and click the [Printer properties] menu of the printer driver.
- 3 Click [Preference] in [General].

2 Register the user.

- 1 Click the [Preference] tab.

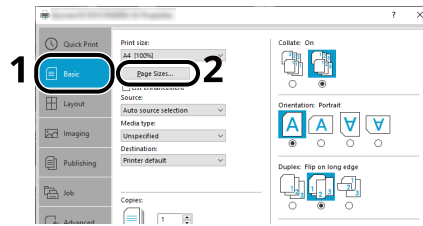

- 2 Click the [Paper Sizes] button.
- 3 Click the [New] button.

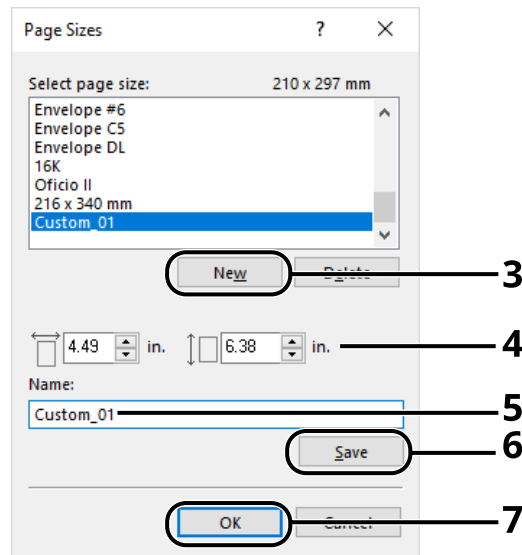

- 4 Enter the paper size.
- 5 Enter the name of the paper.
- 6 Click the [Save] button.
- 7 Click the [OK] button.
- 8 Click the [OK] button.

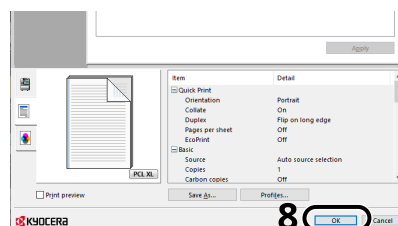

3 Display the print settings screen.

Click [File] and select [Print].

4 Select the paper size and type of non-standard size paper.

1 Select the machine from the "Printer" menu and click the [Properties] button.

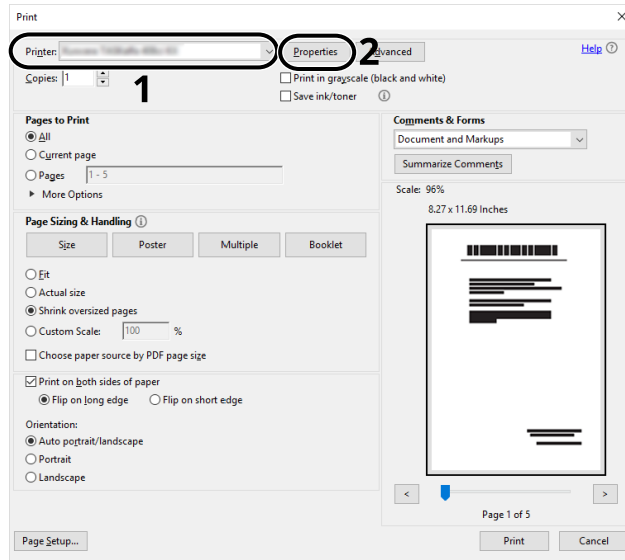

2 Select the [Preference] tab.

3 Click "Paper size" menu and select the paper size registered in step 2.

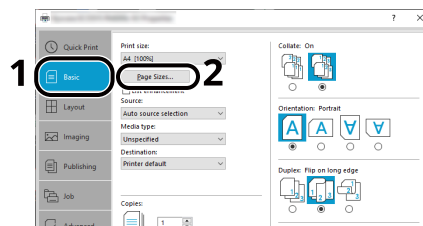

To print on the special paper such as thick paper or transparency, click the [Media type] menu and select the media type.

NOTE

If you loaded a postcard or envelope, select [Hagaki] or [Envelope] in the "Media type" menu.

4 Select the paper source in the "Source" menu.

5 Click the [OK] button to return to the Print dialog box.

5 Start printing.

Click the [OK] button.

Printing with Universal Print

Jobs can be printed via the cloud by using the cloud service [Universal Print] provided by Microsoft Corporation. Users authorized in the Azure Active Directory can print to Universal Print ready printers from anywhere.

NOTE

- A Microsoft 365 license and an Azure Active Directory account are necessary in order to use Universal Print. If you do not have one, please obtain these licenses and accounts.
 - In order to use Universal Print, the following prerequisites need to be met:
 - A Universal Print-eligible license must be assigned to the user account used
 - Printer Administrator or Global Administrator privileges must be assigned to all administrators
-

Registering the Machine to Universal Print

1 Start up the browser.

Specify `https://[Host name]` and start Command Center RX.

2 Display the screen

[Functions] > [Printer] > "Universal Print Settings" > [Settings]

3 Configure the settings

- 1 Enter "Remote Printer Name" of "Basic".
-

NOTE

Set the proxy if required.

➔ [Command Center RX User Guide](#)

- 2 Click "Universal Print" in [Register].
A Microsoft URL and an access code are displayed.
 - 3 Click the URL and enter the access code obtained in Step 2 > [Next]
 - 4 Log in as Azure administrator.
-

NOTE

Credential is required only when you register for the first time. Click [Approve].

- 5 Close the Microsoft web page and return to the Command Center RX screen.

- 6 Click [OK].
Returns to the Universal Print Settings screen.

 **NOTE**

Once registration is complete, [Register] in "Universal Print" will change to [Unregister], and the expiration date of certificate will be shown. Click [Refresh] if the display remains unchanged.

- 7 Click [Edit] in "Universal Print Preferences" and copy the unregister URL.
- 8 Open a new tab in the browser and past the URL.
You will be redirected to the Universal Print web page.
- 9 Click [Printer].
Registered printers are displayed.
- 10 Check the box for this machine and click [Sharing].
The "Share printer" screen is displayed.
- 11 Select the users you want to share this machine with from the "Select member" menu and click the [Share this printer] button.

 **NOTE**

Enable [Allow to access all member] to share this machine with all users in your organization.

- 12 Close the Universal Print web page.

Registering a Shared Printer to a Computer

To use Universal Print, it is necessary to add a shared printer registered with Universal Print to the computer.

1 Login

- 1 Select the Windows Start button → [Settings] → [Accounts] → [Access work or school], in that order.
- 2 Confirm that the Azure administrator account name is displayed in [Access work or school], and click it.



NOTE

If the Azure administrator account name is not displayed, click [+] (Connect), and use the Azure administrator account name and password to log in.

2 Display the screen

Select [Home] → [Devices] → [Printers and scanners], in that order.

3 Configure the settings

- 1 Click [Adding Printer or Scanner in Windows].
- 2 Select the shared printer and click [Add device].
The shared printer is registered.

Print the Job

1 Display the screen

Select [File] and click [Print].

2 Configure the settings

1 Select a registered shared printer from the [Printer] menu and click the [Properties] button.

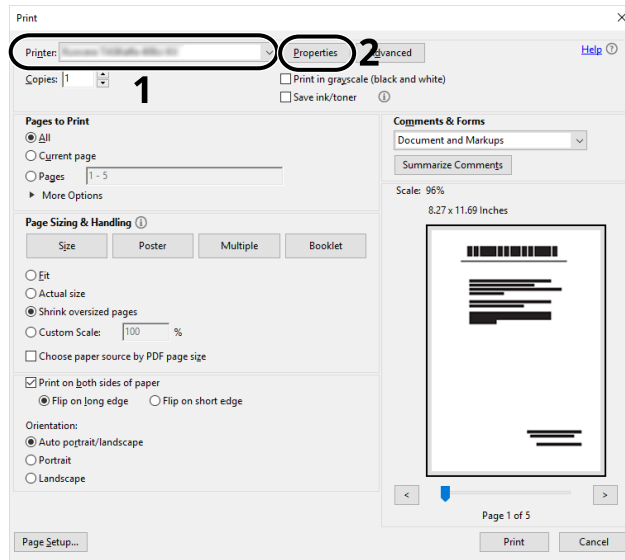

2 Set the paper size, printer function, etc., as desired.

3 Click [OK] button to return to the Print dialog box.

3 Start printing.

Click the [OK] button.

Canceling Printing from a Computer

To cancel a print job executed using the printer driver before the printer begins printing, do the following:

 **NOTE**

When canceling printing from this machine, refer to the following:

→ [Canceling Jobs \(page 233\)](#)

- 1** Double-click the printer icon () displayed on the taskbar at the bottom right of the Windows desktop to display a dialog box for the printer.
- 2** Click the file for which you wish to cancel printing and select [Cancel] from the "Document" menu.

Printing from the Mobile Device

This machine supports the AirPrint and Mopria. According to the supported OS and application, you can print the job from any mobile device or computer without installing a printer driver.

Printing by AirPrint

AirPrint is a printing function that is included standard in iOS 4.2 and later products, and Mac OS X 10.7 and later products. To use the AirPrint, make sure that the AirPrint setting is enabled in the Command Center RX.

➔ [Command Center RX User Guide](#)



Printing by Mopria

Mopria is a standard on printing function included in Android 4.4 or later products. Mopria Print Service needs to be installed and enabled in advance. For details on how to use, refer to a Web site of Mopria Alliance.



Printing with Wi-Fi Direct

Wi-Fi Direct is a wireless LAN standard that Wi-Fi Alliance has been established. This is one of the functions of the wireless LAN, without a wireless LAN access point or wireless LAN router, between devices can communicate directly on a peer to peer basis.

The printing procedure by the Wi-Fi Direct is the same as that from the normal mobile devices.

When you use a printer name or Bonjour name on the port settings of the printer property, you can print the job by specifying the name at Wi-Fi Direct connection. When you use an IP address for the port, specify the IP address of this machine.

Printing Data Saved in the Printer

You can save the print job into the Job Box of this device and print it as necessary.

An SD/SDHC Memory Card is required to use the Stored Job Box and the Quick Copy Box.

IMPORTANT

SD/SDHC memory cards store unencrypted data. Please be careful when storing sensitive documents.

NOTE

When using the Job Box with an SD/SDHC memory card, set [RAM Disk Mode] to [Off].

If you configure settings in the [Store job] tab of the printer driver and then print, the print job will be saved in the Job Box (memory) and printing can be executed at the machine.

To print the job in Job Box, specify the Job Box from a computer and sending the print job, then specify a file within a Box and printing it, using the operation panel.

You can print the documents from the following boxes.

- Private Print Box
 - ➔ [Printing Documents from Private Print Box \(page 195\)](#)
- Stored Job Box
 - ➔ [Printing Document from Stored Job Box \(page 197\)](#)
- Quick Copy Box
 - ➔ [Printing Document from Quick Copy Box \(page 200\)](#)
- Proof and Hold Box
 - ➔ [Printing Document from Proof and Hold Box \(page 202\)](#)
- PIN Print Box
 - ➔ [Printing Documents from PIN Print Box \(page 204\)](#)
- Universal Print Box
 - ➔ [Printing the Documents Stored in the Universal Print Box \(page 207\)](#)

Specifying the Job Box from a Computer and Storing the Job

1 Click [File] and select [Print] in the application.

The Print dialog box displays.

2 Click the [▼] button of the Name to select the machine from the list.

3 Click the [Properties] button.

The Properties dialog box displays.

4 Click the [Job storage] tab and select the [Job enhancement] check box to set the function.



NOTE

For information on how to use the printer driver software, refer to the following:

➔ **Printer Driver User Guide**

Printing Documents from Private Print Box

In Private Printing, you can specify that a job is not to be printed until you operate the machine. When sending the job from the application software, specify a password in the printer driver. The job is released for printing by entering the password on the operation panel, ensuring confidentiality of the print job. The data will be deleted upon completion of the print job or after the power switch is turned off.

1 Display the screen

- 1 [Document Box] key > [▲][▼] keys > [Job Box] > [OK] key > [▲][▼] keys > [Private Print] > [OK] key
- 2 Select the creator of the document, and select the [OK] key.

2 Print the document.

- 1 Select the document you wish to print and select [Select] > [OK] key.
Select a document and a checkmark will appear on the right side of the selected document.
If you select a document marked with a checkmark and once again select [Select], the selection will be cleared.



NOTE

If you select [Menu], you can perform the following operations.

- [Clear All]: Deselect all documents.
 - [Select All]: Select all documents.
 - [Detail]: Display the details for the selected document.
-

- 2 [▲][▼] keys > [Print] > [OK] key
- 3 Enter the password > [OK] key
- 4 Enter the number of copies to print and the [OK] key > [Yes]
Printing starts.
Upon completion of printing, the Private Print job is automatically deleted.

Deleting the Documents Stored in the Private Print Box

1 Display the screen

- 1 [Document Box] key > [▲][▼] keys > [Job Box] > [OK] key > [▲][▼] keys > [Private Print] > [OK] key
- 2 Select the creator of the document, and select the [OK] key.

2 Delete the document.

- 1 Select the document to delete and [OK] key

Select a document and a checkmark will appear on the right side of the selected document.

If you select a document marked with a checkmark and once again select [Select], the selection will be cleared.



NOTE

If you select [Menu], you can perform the following operations.

- [Clear All]: Deselect all documents.
 - [Select All]: Select all documents.
 - [Detail]: Display the details for the selected document.
-

- 2 [▲][▼] keys > [Delete] > [OK] key
- 3 Enter the password > [OK] key > [Yes]
The document is deleted.

Printing Document from Stored Job Box

In Stored Job, the print data sent from the application is saved to the machine. You can set up a password as necessary. If you set up a password, enter the password when printing. Print data will be stored in the Stored Job Box after printing. This will allow printing of the same print data repeatedly.

1 Display the screen

- 1 [Document Box/USB] key > [▲][▼] keys > [Job Box] > [OK] key > [▲][▼] keys > [Private Print] > [OK] key
- 2 Select the creator of the document, and select the [OK] key.

2 Print the document.

- 1 Select the document to print and [Select] > [OK] key

Select a document and a checkmark will appear on the right side of the selected document.

If you select a document marked with a checkmark and once again select [Select], the selection will be cleared.



NOTE

If you select [Menu], you can perform the following operations.

- [Clear All]: Deselect all documents.
 - [Select All]: Select all documents.
 - [Detail]: Display the details for the selected document.
-

- 2 [▲][▼] keys > [Print] > [OK] key
- 3 Enter the number of copies to print and the [OK] key > [Yes]
Printing starts.



NOTE

If the document is protected by a password, the password entry screen will be displayed. Enter the password with the numeric keypad.

Simple Job Printing

When you save a print job performed via user login to the Stored Job Box, logging in with an IC card at the time of printing displays a list of your print jobs in the Stored Job Box. When you run the print job, printing starts immediately.

User login administration that uses the optional IC Card Authentication Kit is required. For details on user login administration for printing, refer to the following:

- ➔ [Adding a User \(Local User List\) \(page 487\)](#)
- ➔ [Managing the Users that Print on This Machine from a PC \(page 494\)](#)

For IC card settings, refer to the following:

- ➔ [ID Card Settings \(page 510\)](#)

For Simple Job Printing settings, refer to the following:

➔ [Simple Job Printing \(page 512\)](#)

Deleting the Documents Stored in the Stored Job Box

1 Display the screen

- 1 [Document Box] key > [▲][▼] keys > [Job Box] > [OK] key > [▲][▼] keys > [Private Print] > [OK] key
- 2 Select the creator of the document, and select the [OK] key.

2 Delete the document.

- 1 Select the document to delete and [Select] > [OK] key

Select a document and a checkmark will appear on the right side of the selected document.

If you select a document marked with a checkmark and once again select [Select], the selection will be cleared.



NOTE

If you select [Menu], you can perform the following operations.

- [Clear All]: Deselect all documents.
- [Select All]: Select all documents.
- [Detail]: Display the details for the selected document.

-
- 2 [▲][▼] keys > [Delete] > [OK] key > [Yes]

The document is deleted.



NOTE

If the document is protected by a password, the password entry screen will be displayed. Enter the password with the numeric keypad.

Printing Document from Quick Copy Box

Quick Copy feature facilitates additional prints of a document already printed. Activating Quick Copy and printing a document using the printer driver allow the print data to be stored in the Quick Copy Job Box. When additional copies are required, you can reprint the required number of copies from the touch panel. By default, up to 32 documents can be stored. When power is turned off, all stored jobs will be deleted.

NOTE

- When the number of jobs reaches the limit, the oldest job will be overwritten by the new one.
- To maintain free space on the hard disk, you can set the maximum number of stored jobs.

➔ [Quick Copy Jobs \(page 474\)](#)

1 Display the screen

- 1 [Document Box] key > [▲] [▼] keys > [Job Box] > [OK] key > [▲] [▼] keys > [Quick/Proof] > [OK] key
- 2 Select the creator of the document, and select the [OK] key.

2 Print the document.

- 1 Select the document to print and [Select] > [OK] key

Select a document and a checkmark will appear on the right side of the selected document.

If you select a document marked with a checkmark and once again select [Select], the selection will be cleared.

NOTE

If you select [Menu], you can perform the following operations.

- [Clear All]: Deselect all documents.
 - [Select All]: Select all documents.
 - [Detail]: Display the details for the selected document.
-

- 2 [▲] [▼] keys > [Print] > [OK] key
- 3 Enter the number of copies to print and the [OK] key > [Yes]
Printing starts.

Deleting the Documents Stored in the Quick Copy Box

1 Display the screen

- 1 [Document Box] key > [▲][▼] keys > [Job Box] > [OK] key > [▲][▼] keys > [Quick/Proof] > [OK] key
- 2 Select the creator of the document, and select the [OK] key.

2 Delete the document.

- 1 Select the document to delete and [Select] > [OK] key

Select a document and a checkmark will appear on the right side of the selected document.

If you select a document marked with a checkmark and once again select [Select], the selection will be cleared.



NOTE

If you select [Menu], you can perform the following operations.

- [Clear All]: Deselect all documents.
 - [Select All]: Select all documents.
 - [Detail]: Display the details for the selected document.
-

- 2 [▲][▼] keys > [Delete] > [OK] key > [Yes]

The document is deleted.

Printing Document from Proof and Hold Box

The Proof and Hold feature produces only a single proof print of multiple-print job and holds printing of the remaining copies. Printing a multiple-print job in Proof and Hold using the printer driver allows only a single copy to be printed while maintaining the document data in the Job Box. To continue to print the remaining copies, use the touch panel. You can change the number of copies to print.

1 Display the screen

- 1 [Document Box] key > [▲][▼] keys > [Job Box] > [OK] key > [▲][▼] keys > [Proof and Hold] > [OK] key
- 2 Select the creator of the document, and select the [OK] key.

2 Print the document.

- 1 Select the document to print and [Select] > [OK] key

Select a document and a checkmark will appear on the right side of the selected document.

If you select a document marked with a checkmark and once again select [Select], the selection will be cleared.



NOTE

If you select [Menu], you can perform the following operations.

- [Clear All]: Deselect all documents.
- [Select All]: Select all documents.
- [Detail]: Display the details for the selected document.

-
- 2 [▲][▼] keys > [Print] > [OK] key
 - 3 Enter the number of copies to print and the [OK] key > [Yes]
Printing starts.

Deleting the Documents Stored in the Proof and Hold Box

1 Display the screen

- 1 [Document Box] key > [▲][▼] keys > [Job Box] > [OK] key > [▲][▼] keys > [Proof and Hold] > [OK] key
- 2 Select the creator of the document, and select the [OK] key.

2 Delete the document.

- 1 Select the document to delete and [Select] > [OK] key

Select a document and a checkmark will appear on the right side of the selected document.

If you select a document marked with a checkmark and once again select [Select], the selection will be cleared.



NOTE

If you select [Menu], you can perform the following operations.

- [Clear All]: Deselect all documents.
 - [Select All]: Select all documents.
 - [Detail]: Display the details for the selected document.
-

- 2 [▲][▼] keys > [Delete] > [OK] key > [Yes]

The document is deleted.

Printing Documents from PIN Print Box

This PIN Print Box holds printing when printing is executed from applications that use the IPP protocol, such as AirPrint and Mopria. A pending print job can be output by entering the PIN code that was set at the time of printing.

1 Display the screen

- 1 [Document Box] key > [▲][▼] keys > [Job Box] > [OK] key > [▲][▼] keys > [PIN Print] > [OK] key
- 2 Select the creator of the document, and select the [OK] key.

2 Print the document.

- 1 Select the document to print and > [Select] > [OK] key
- 2 [▲][▼] keys > [Print] > [OK] key
- 3 Enter the PIN code to print, and [OK] key > [Yes]

Printing starts.

Upon completion of printing, the PIN Print job is automatically deleted.

Deleting the Documents Stored in the PIN Print Box

1 Display the screen

- 1 [Document Box] key > [▲][▼] keys > [Job Box] > [OK] key > [▲][▼] keys > [PIN Print] > [OK] key
- 2 Select the creator of the document, and select the [OK] key.

2 Delete the document.

- 1 Select the document to delete and [Select] > [OK] key
- 2 [▲][▼] keys > [Delete] > [OK] key
- 3 Enter the PIN code to print, and [OK] key > [Yes]
The document is deleted.

Printing Document from Universal Print Box

For added security, Universal Print can set a PIN code for the printing jobs. Jobs with a PIN code will be saved in the cloud without being printed. By entering the PIN code from the operation panel, jobs from this machine can be printed.

NOTE

- To use Universal Print, this machine must be registered as a shared printer.
➔ [Registering the Machine to Universal Print \(page 185\)](#)
- To use the Universal Print box, you need a Windows 11 and Microsoft 365 license and an Azure Active Directory account.

Storing a Job in the Universal Print Box

1 Display the screen

Click [File] and select [Print].

2 Configure the settings

- 1 Select a registered shared printer from the "Printer" menu and click the [Properties] button.

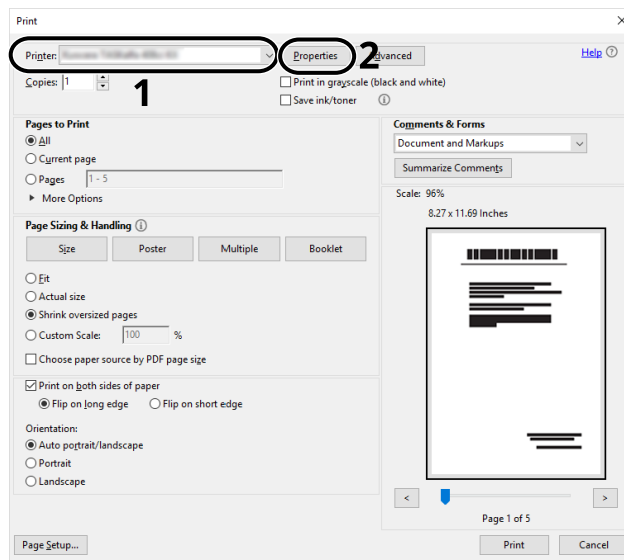

- 2 Click [Advanced settings].

- 3 Set [PIN-protected printing] to [On], and set a PIN code (4 digits) as the [PIN-protected printing PIN].

- 4 Select the [OK] button > the [OK] button to return to the Print dialog box.

3 Start printing.

Click the [OK] button.

Printing the Documents Stored in the Universal Print Box

1 Display the screen

- 1 [Document Box] key > [▲][▼] keys > [Job Box] > [OK] key > [▲][▼] keys > [Universal Print] > [OK] key
- 2 Select the creator of the document, and select the [OK] key.

2 Print the document.

- 1 Select the document to print and [Select] > [OK] key

Select a document and a checkmark will appear on the right side of the selected document.

If you select a document marked with a checkmark and once again select [Select], the selection will be cleared.



NOTE

If you select [Menu], you can perform the following operations.

- [Clear All]: Deselect all documents.
 - [Select All]: Select all documents.
 - [Details]: Display the details for the selected document.
-

- 2 [▲][▼] keys > [Print] > [OK] key > Enter the PIN code > [OK] key > [Yes]

Deleting the Documents Stored in the Universal Print Box

1 Display the screen

- 1 [Document Box] key > [▲][▼] keys > [Job Box] > [OK] key > [▲][▼] keys > [Universal Print] > [OK] key
- 2 Select the creator of the document, and select the [OK] key.

2 Delete the document.

- 1 Select the document to delete and [Select] > [OK] key

Select a document and a checkmark will appear on the right side of the selected document.

If you select a document marked with a checkmark and once again select [Select], the selection will be cleared.



NOTE

If you select [Menu], you can perform the following operations.

- [Clear All]: Deselect all documents.
 - [Select All]: Select all documents.
 - [Detail]: Display the details for the selected document.
-

- 2 [▲][▼] keys > [Delete] > [OK] key > Enter the PIN code > [OK] key > [Yes]

The document is deleted.

Job Box Settings

Configure settings for Job Box.

1 Display the screen

[System Menu/Counter] key > [▼] key > [Document Box] > [OK] key > [▲] [▼] keys > [Job Box] > [Quick Copy Jobs] or [JobRet. Deletion]

2 Configure the settings

Configurable items are as follows:

[Quick Copy Jobs]

To maintain free space on the hard disk, you can set the maximum number of stored jobs.

Value: number between 0 and 300



NOTE

When 0 is set, Quick Copy cannot be used.

[JobRet. Deletion]

This setting specifies that documents, such as Private Printing, Quick Copying, or Proof and Hold Printing, saved temporarily in the job box are automatically deleted after they have been saved for a set time.

Value: [Off], [1 hour], [4 hours], [1 day], [1 week]



NOTE

This function is valid for documents saved after the function is set. Regardless of this function setting, temporary documents are deleted when the power switch is turned off.

[Storage Media]

Set the save destination of Job Box.

Displayed when the optional SD card is installed.

Value:

Monitoring the Printer Status (Status Monitor)

The Status Monitor monitors the printer status and provides an ongoing reporting function.



NOTE

When you activate Status Monitor, check the status below.

- KX DRIVER is installed.
- Either [Enhanced WSD] or [EnhancedWSD(TLS)] is enabled.

➔ [\[ProtocolSettings\] \(page 394\)](#)

Accessing the Status Monitor

The Status Monitor also starts up when printing is started.

Exiting the Status Monitor

Use either of the methods listed below to exit the Status Monitor.

Exit manually

Click the settings icon and select Exit in the menu to exit the Status Monitor.

Exit automatically

The Status Monitor automatically shuts down after 7 minutes if it is not being used.

Quick View State

The status of the printer is displayed using icons. Detailed information is displayed when the Expand button is clicked.

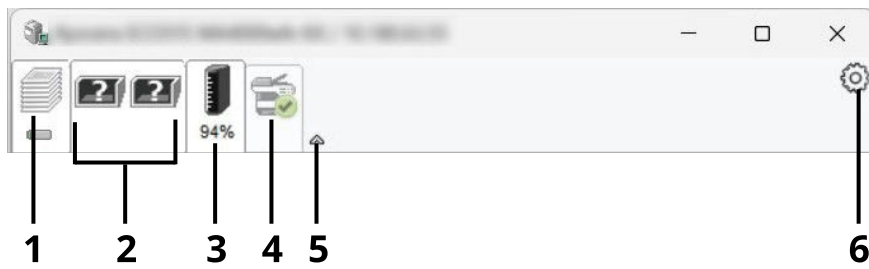

- 1 Printing progress tab
- 2 Paper tray status tab
- 3 Toner Status Tab
- 4 Alert tab
- 5 Expand button
- 6 Settings icon

Detailed information is displayed by clicking on each icon tab.

Printing progress tab

The status of the print jobs is displayed.

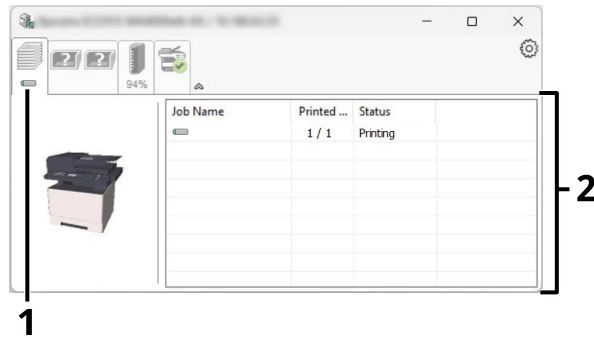

1 Status icon

2 Job list

Select a job on the job list and it can be canceled using the menu displayed with a right-click.

Paper tray status tab

Information is displayed about the paper in the printer and about the amount of paper remaining.

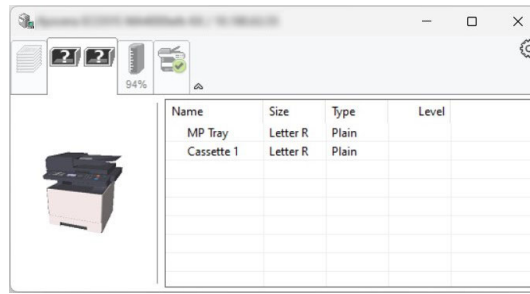

Toner Status Tab

The amount of toner remaining is displayed.

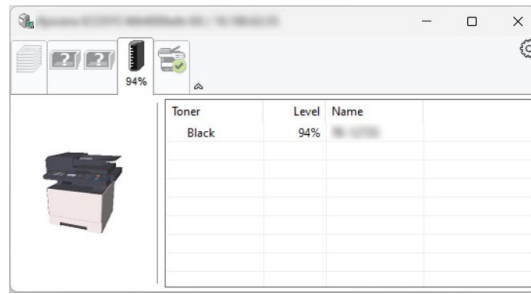

Alert tab

If an error occurs, a notice is displayed using a 3D image and a message.

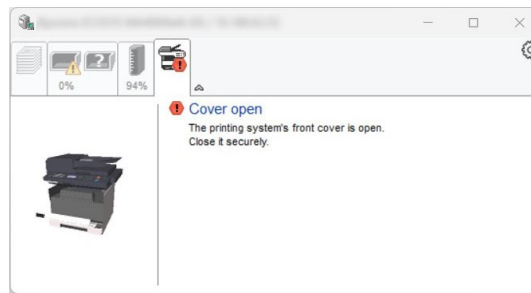

Status Monitor Context Menu

The following menu is displayed when the settings icon is clicked.

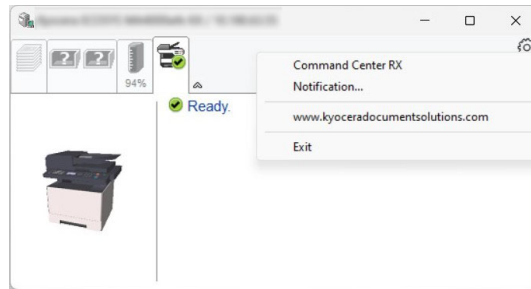

[Command Center RX]

If the printer is connected to a TCP/IP network and has its own IP address, use a web browser to access the Command Center RX to modify or confirm the network settings. This menu is not displayed when using USB connection.

➔ **Command Center RX User Guide**

[Notification...]

This sets the display of the Status Monitor.

➔ [Status Monitor Notification Settings \(page 218\)](#)

[www.kyoceradocumentsolutions.com]

Open our website.

[Exit]

Exits the Status Monitor.

Status Monitor Notification Settings

The Status Monitor settings and event list details are displayed.

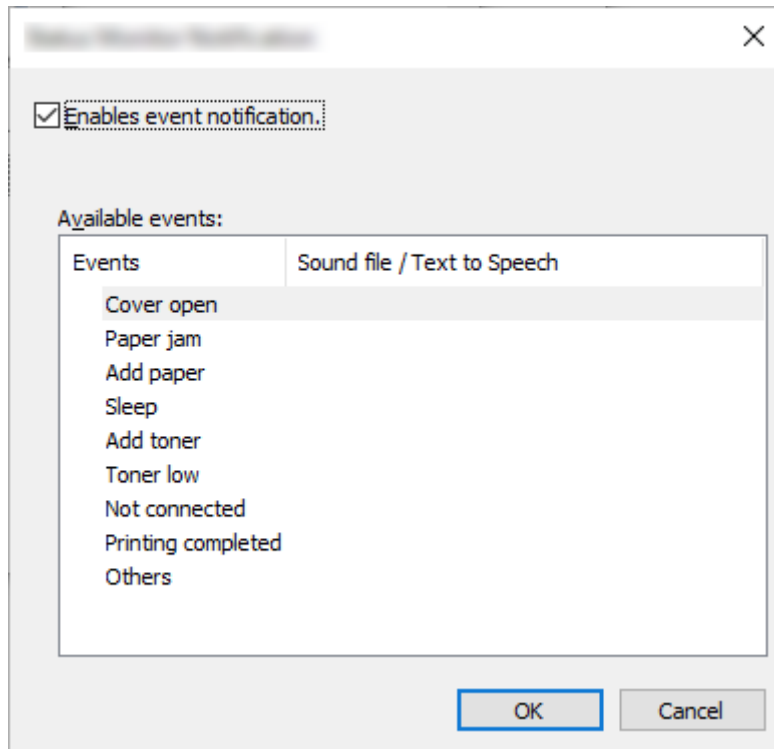

Select whether notification is performed when an error in the event list occurs.

1 Select "Enable event notification".

If this setting is set to Off, then the Status Monitor will not start up even when printing is executed.

2 Select an event to use with the text to speech function in Available events.

3 Click the "Sound file / Text to Speech" field.

Click the browse (...) button to notify the event by sound file.

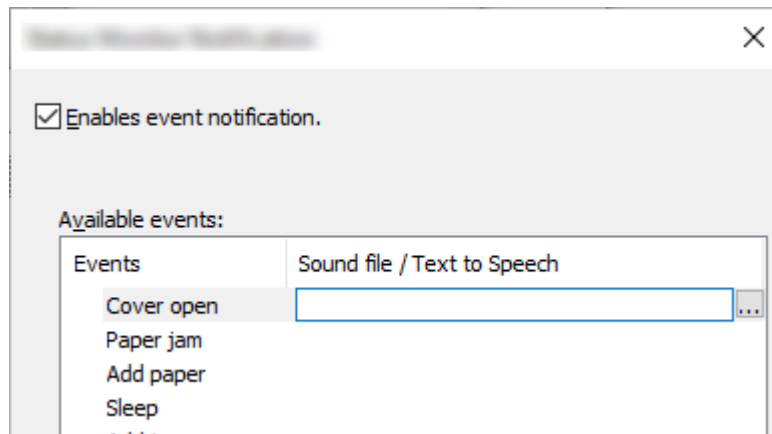

 **NOTE**

The available file format is WAV.

When customizing the message texts to read on the screen aloud, enter the texts in the text box.

5 Operation on the Machine

Loading Originals

Load the originals on the platen or document processor, depending on the original size, type, volume, and function.

Platen

Place the sheet, book, postcards, and envelopes.

Document Processor

Place the multiple originals. You can also place the two sided originals.

Placing Originals on the Platen

You may place books or magazines on the platen in addition to ordinary sheet originals.

- 1 Put the scanning side facedown.

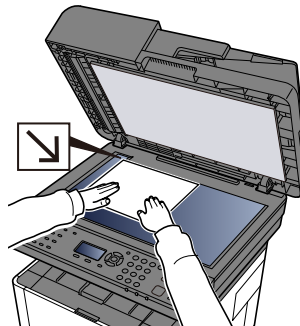

- 2 Align it flush against the original size indicator plates with the back left corner as the reference point.

NOTE

For details on Original Orientation, refer to the following:

➔ [Original Size \(page 286\)](#)

Placing Envelopes or Cardstock on the Platen

- 1 Put the scanning side facedown.

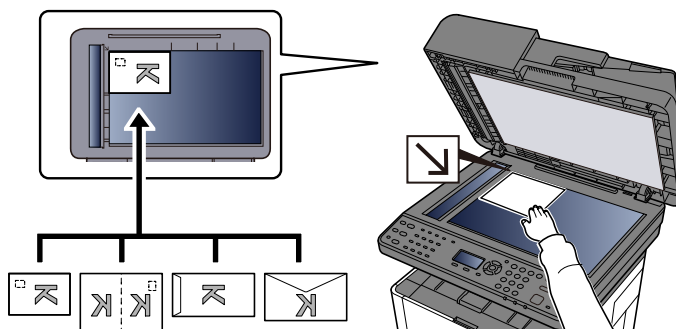

2 Align it flush against the original size indicator plates with the back left corner as the reference point.



NOTE

For the procedure for feeding envelopes or cardstock, refer to the following:

➔ [Loading Paper in the Multipurpose Tray \(page 138\)](#)



CAUTION

Do not leave the Document Processor open. Doing so may cause injury.



IMPORTANT

- Do not push the document processor forcefully when you close it. Excessive pressure may crack the platen glass.
 - When placing books or magazines on the machine, do so with the document processor in the open position.
-

Original Specifications available in the Document Processor

The document processor automatically scans each sheet of multiple originals. Both sides of two-sided originals are scanned.

Originals Supported by the Document Processor

The document processor supports the following types of originals.

Item	Description
Thickness	50 to 160g/m ² (duplex: 50 to 160 g/m ²) Applicable to MFP
Size	100 x 148 mm to 216 x 356 mm
No. of sheets	50 sheets (80 g/m ²) maximum

Originals Not Supported by the Document Processor

Do not use the document processor for the following types of originals. Otherwise, the originals may be jammed or the document processor may become dirty.

- Originals bound with clips or staples (Remove the clips or staples and straighten curls, wrinkles or creases before loading. Failure to do so may cause the originals to jam.)
- Originals with adhesive tape or glue
- Originals with cut-out sections
- Curled original
- Originals with folds (Straighten the folds before loading. Failure to do so may cause the originals to jam.)
- Carbon paper
- Crumpled paper

Loading Originals in the document processor

IMPORTANT

- Before loading originals, be sure that there are no originals left on the original eject table. Originals left on the original eject table may cause the new originals to jam.
- Do not make an impact on the document processor top cover, such as aligning the originals on the top cover. It may cause an error in the document processor.

- 1 **Open the document tray and adjust the document width guide to the document size.**

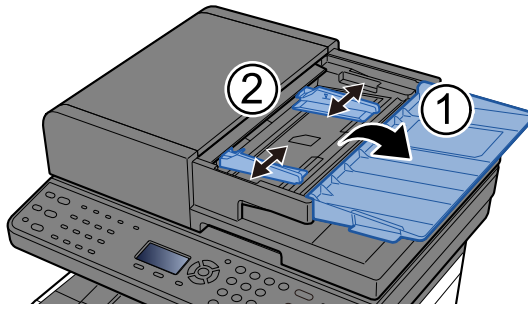

- 2 **Load paper.**

- 1 Put the side to be scanned (or the first side of two-sided originals) face-up.

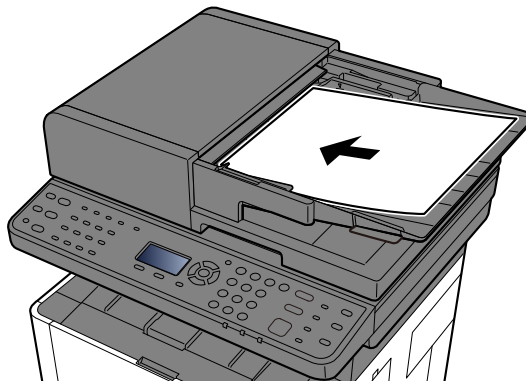

NOTE

For details on Original Orientation, refer to the following:

➔ [Orig.Orientation \(page 291\)](#)



IMPORTANT

Confirm that the original width guides exactly fit the originals. If there is a gap, readjust the original width guides. The gap may cause the originals to jam.

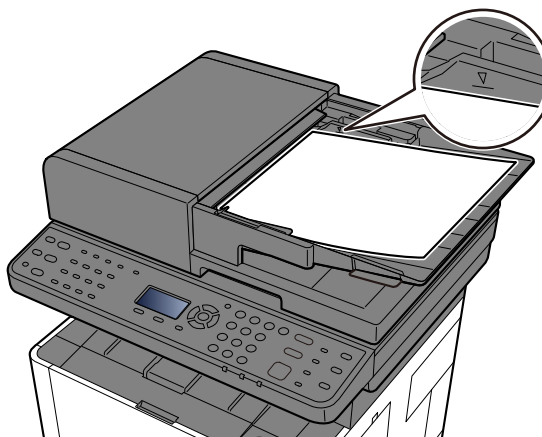

Ensure that loaded originals do not exceed the level indicator. Exceeding the maximum level may cause the originals to jam.

Originals with punched holes or perforated lines should be placed with the punched holes or perforated lines facing forward (so that they will be scanned last).

- 2 Open the original stopper. (If the original size is Folio/Legal)

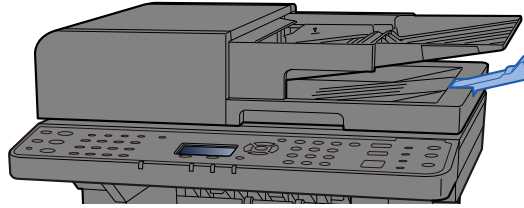

Recalling Frequently Used Functions (Program 1)

You can combine frequently used functions and register them as a program. After registration, you can call up simply by selecting one of [Program 1] to [Program 4].

[Program 1] is preset with the ID card copy function. Using this function, you can copy the front and back sides of documents up to A5/Statement size, such as ID cards, onto one side. Overwriting will delete the settings, but you can use the [Function Menu] key to restore the same settings.

- Paper selection Cassette 1
- Zoom (XY Zoom): 100%
- Combine: 2 in 1
- Original Size: A5/Statement
- Continuous loading: Configure the settings

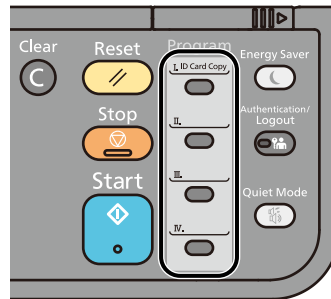

NOTE

- Copy, send, and fax functions can be registered in the program.
- If user login administration is enabled, you can only register functions by logging in with administrator privileges.

Register the program

1 Configure the settings

Configure the printing function to be registered in the program.

For details on each function, see below:

➔ [Using Various Functions \(page 276\)](#)

NOTE

For sending or faxing, you can also register destinations in the program.

2 Register the program

Among the [Program 1] to [Program 4] keys, press and hold the key whose settings you want to register for at least 2 seconds.

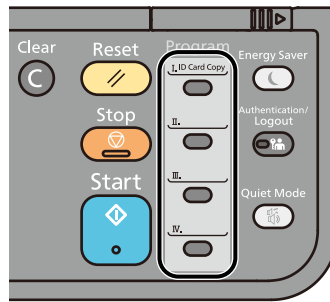

The current settings will be registered to the selected program key.

Recall the program

- 1 Select the key in which the setting you want to recall is registered from among the [Program 1] to [Program 4] keys.**

The settings of various functions will be replaced with the registered settings.

- 2 Place the originals and press the [Start] key.**

overwrite the program

1 Configure the settings

Set the function you want to change.

For details on each function, see below:

➔ [Using Various Functions \(page 276\)](#)



NOTE

For sending or faxing, you can also register destinations in the program.

2 overwrite the program

- 1 Among the [Program 1] to [Program 4] keys, press and hold the key you want to change for at least 2 seconds.

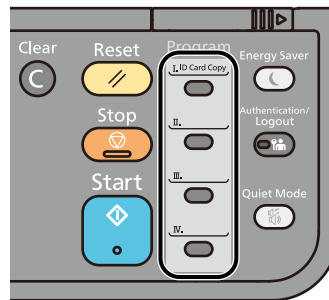

- 2 [▲][▼] keys > [Overwrite] > [OK] key > [Yes]

Register the changed program.

Delete the program

1 Display the screen

Among the [Program 1] to [Program 4] keys, press and hold the key you want to delete for at least 2 seconds.

2 Delete the program

[▲][▼] keys > [Delete] > [OK] key > [Yes]

Selection key settings

Frequently used functions can be registered on the selection keys. You can easily set it by selecting the selection key.

You can register functions to selection keys from the System Menu.

➔ [Copy \(page 466\)](#)

➔ [Send \(page 470\)](#)

➔ [Document Box \(page 474\)](#)

Copying

The procedures here represent the basic copy operation and how to cancel the copy.

Copy

- 1 **Select the key**
- 2 **Load paper.**

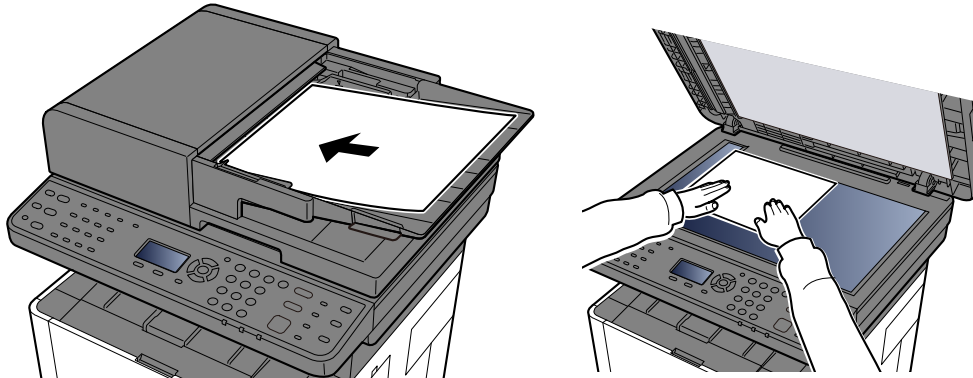

➔ [Loading Originals \(page 221\)](#)

Select the original size and paper size.



NOTE

For the procedure for specifying an original size, refer to the following.

➔ [Original Size \(page 286\)](#)

For the procedure for specifying a paper source, refer to the following.

➔ [Paper Selection \(page 287\)](#)

3 **Configure the settings**

Select the [Function Menu] key to set paper selection, reduction/enlargement, etc.

➔ [Copy \(page 278\)](#)

4 **Use the numeric keys to enter the copy quantity.**

Specify the desired number up to 999.

5 **Press the [Start] key.**

Copying begins.

Canceling Jobs

1 Select the key with the copy screen displayed.

2 Cancel a job.

1 [▲] [▼] keys > [Cancel Print Job] > [OK] key

2 Select the job to cancel, and select [Menu].

3 [▲] [▼] keys > [Cancel Job] > [OK] key



NOTE

Select [Detail], and the [OK] key and detailed information of the job is displayed.

4 Select [Yes].

The job is canceled.



NOTE

A job in the middle of scanning can be canceled by selecting the [Stop] key or [Cancel] key.

Basic Scanning (Sending)

This machine can send a scanned image as an attachment of an E-mail message or to a PC linked to the network. In order to do this, it is necessary to register the sender and destination (recipient) address on the network.

A network environment which enables the machine to connect to a mail server is required in order to send E-mail. It is recommended that a Local Area Network (LAN) be used to assist with transmission speed and security issues.

Follow the steps below for basic sending. The following four options are available.

- Send as E-mail (E-mail Addr Entry): Sends a scanned original image as an E-mail attachment.

➔ [Sending Document via E-mail \(page 235\)](#)

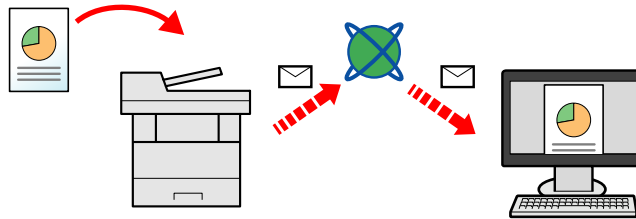

- Send to Folder (SMB): Stores a scanned original image in a shared folder of any PC.

➔ [Sending Document to Desired Shared Folder on a Computer \(Scan to PC\) \(page 236\)](#)

- Send to Folder (FTP): Stores a scanned original image in a folder of an FTP server.

➔ [Sending Document to Folder on an FTP Server \(Scan to FTP\) \(page 238\)](#)

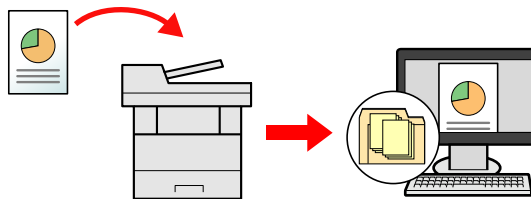

- Image Data Scanning with TWAIN / WIA: Scan the document using a TWAIN or WIA compatible application program.

➔ [Scanning using TWAIN or WIA \(page 240\)](#)

NOTE

- Different sending options can be specified in combination.

➔ [Sending to different types of destinations \(Multi sending\) \(page 245\)](#)

- The fax function can be used for sending.

Fax function is available for fax models.

➔ **FAX Operation Guide**

Sending Document via E-mail

NOTE

- When transmitting using wireless LAN, select the interface dedicated to the send function in advance.
➔ [\[Primary Network\] \(page 404\)](#)
- Before sending the scanned document with an E-mail, configure the SMTP and E-mail settings using the Command Center RX.
➔ [SMTP and E-mail Settings \(page 116\)](#)

1 Select the key

2 Load paper.

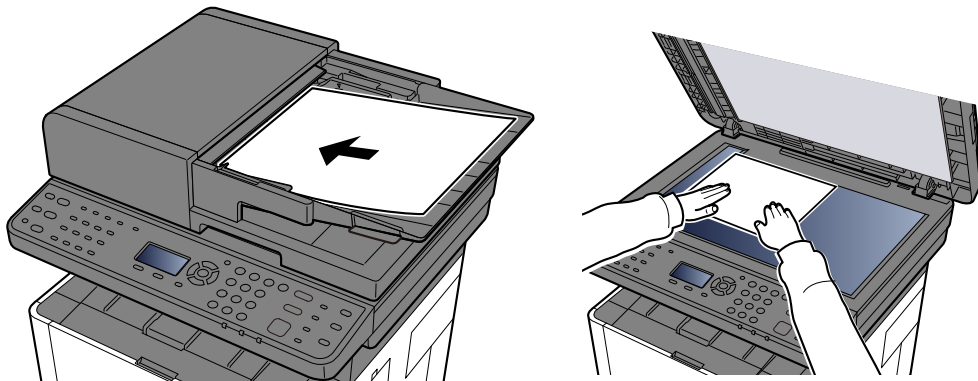

➔ [Loading Originals \(page 221\)](#)

3 [**▲**][**▼**] keys > [E-mail] > [OK] key

4 Enter address > [OK] key

Up to 128 characters can be entered.

➔ [Character Entry \(page 761\)](#)

To enter multiple destinations, select the [Destination] key and enter the next destination. Up to 100 E-mail addresses can be specified.

Destinations can be changed later.

➔ [Checking and Editing Destinations \(page 255\)](#)

5 Configure the settings

Select the [Function Menu] key and set the sending function to use.

➔ [Send \(page 280\)](#)

6 Press the key.

Sending starts.

Sending Document to Desired Shared Folder on a Computer (Scan to PC)

You can store the scanned document into the desired shared folder on a computer.

NOTE

- When transmitting using wireless LAN, select the interface dedicated to the send function in advance.
➔ [\[Primary Network\] \(page 404\)](#)
 - Before sending the scanned document to the shared folder on your computer, you must configure the following settings:
 - Make a note of the computer name and full computer name
➔ [Make a note of the computer name and full computer name \(page 143\)](#)
 - Make a note of the user name and domain name
➔ [Make a note of the user name and domain name \(page 144\)](#)
 - Create a shared folder and make a note of the shared folder name
➔ [Create a shared folder and make a note of the shared folder name \(page 145\)](#)
 - Configure the Windows firewall
➔ [Configuring Windows Firewall \(page 150\)](#)
-

1 Select the key

2 Load paper.

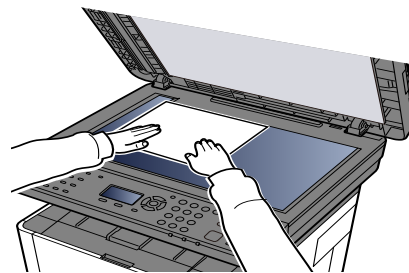
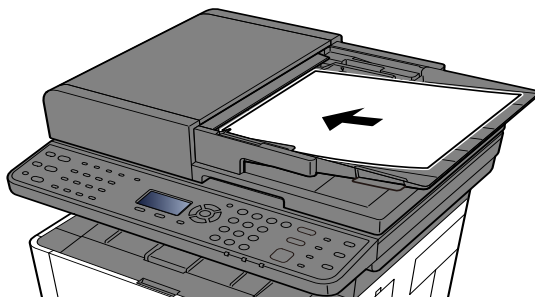

➔ [Loading Originals \(page 221\)](#)

3 [▲][▼] keys > [Folder(SMB)] > [OK] key

4 Enter the destination details.

Enter each item and select the [OK] key.

The table below explains the items to be entered. Enter each item and select the [OK] key.

Item	Description
Host Name	Computer name Limited character count: 64 characters or less
Path	Share name Limited character count: 128 characters or less For example: scannerdata If saving in a folder in the shared folder: share name\folder name in shared folder
Login User Name	<ul style="list-style-type: none"> • If the computer name and domain name are the same User Name For example: james.smith. • If the computer name and domain name are different Domain name\User name For example: abcdnet\james.smith Limited character count: 64 characters or less
Login Password	Logon password. Limited character count: 64 characters or less Upper case and lower case letters are distinguished (case sensitive).

A host name can also specify a Port number. Enter the following format separated by a colon.

"Host name: Port number" or "IP address: Port number"

To enter the IPv6 address, enclose the IPv6 address in brackets [].

(Example: [2001:db8:a0b:12f0::10]:445)

If the port number is not specified, the default port number is 445.

5 Check the information.

The confirmation screen is displayed. Select [Yes] to check the connection. Select [No] to not confirm.

If the connection is successful, [Connected.] is displayed. If [Cannot connect.] is displayed, review the entered items.

To add the destination, repeat steps 3-4.

Destinations can be changed later.

➔ [Checking and Editing Destinations \(page 255\)](#)

6 Configure the settings

Select the [Function Menu] key and set the sending function to use.

➔ [Send \(page 280\)](#)

7 Press the key.

Sending starts.

Sending Document to Folder on an FTP Server (Scan to FTP)

 **NOTE**

- Before sending a document, configure the FTP Client (Transmission).
 → [\[ProtocolSettings\] \(page 394\)](#)

1 Select the key

2 Load paper.

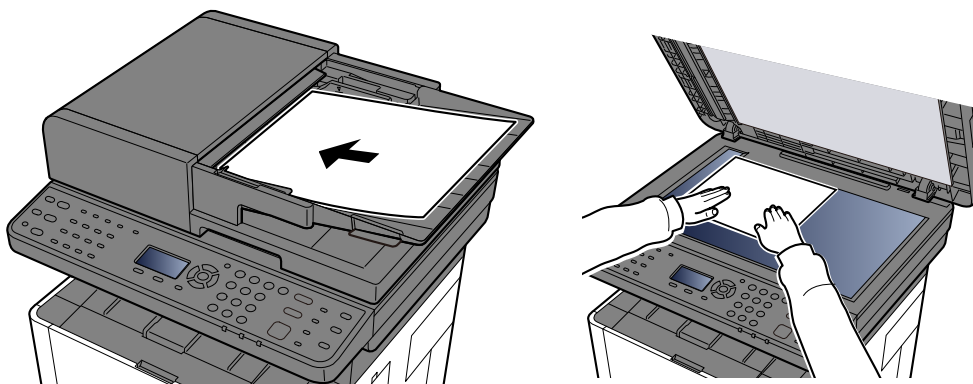

→ [Loading Originals \(page 221\)](#)

3 [▲][▼] keys > [Folder(FTP)] > [OK] key

4 Enter the destination details.

Enter the destination information. Enter each item and select the [OK] key.

→ [Character Entry \(page 761\)](#)

The table below explains the items to be entered.

Item	Description
Host Name	Host name or IP address of FTP server Limited character count: 64 characters or less
Path	Path for the file to be stored Limited character count: 128 characters or less For example: User\ScanData If no path is entered, the file is stored in the home directory.
Login User Name	FTP server login user name Limited character count: 64 characters or less
Login Password	FTP server login password Limited character count: 64 characters or less Upper case and lower case letters are distinguished (case sensitive).

A Host Name name can also be specified with a port number. Enter the following format separated by a colon.

"Host Name: Port number" or "IP Address: Port number"

To enter the IPv6 address, enclose the IPv6 address in brackets [].

(Example: [2001:db8:a0b:12f0::1]21)

If the port number is not specified, the default port number is 21.

When path is for a FTP server based on Linux/UNIX, the path including the sub-folder is combined by the slash "/" not using the back-slash.

5 Check the information.

The confirmation screen is displayed. Select [Yes] to confirm the connection. Select [No] to not confirm.

If the connection is successful, "Connected. " is displayed. If "Cannot connect. " is displayed, review the entered items.

To add the destination, repeat steps 3-4.

Destinations can be changed later.

6 Configure the settings

Select the [Function Menu] key and set the sending function to use.

➔ [Send \(page 280\)](#)

➔ [Checking and Editing Destinations \(page 255\)](#)

7 Press the key.

Sending starts.

Scanning using TWAIN or WIA

This subsection explains how to scan an original using TWAIN. The WIA driver is used in the same way.

NOTE

- Before sending a document, confirm that TWAIN/WIA driver is installed on a computer and the settings are configured.
 - ➔ [Configure TWAIN Driver. \(page 103\)](#)
 - ➔ [Configure WIA Driver. \(page 105\)](#)
-

1 Display the screen

- 1 Activate the TWAIN compatible application software.
 - 2 Select the machine using the application and display the dialog box.
-

NOTE

For selecting the machine, see the Operation Guide or Help for each application software.

2 Configure the settings

Select scanning settings in the dialog box that opens.

NOTE

For the settings, refer to Help in the dialog box.

3 Load paper.

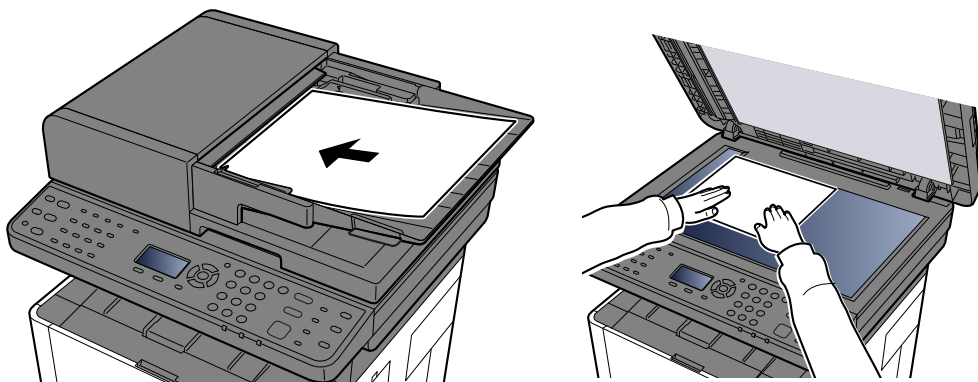

➔ [Loading Originals \(page 221\)](#)

4 Scan the originals.

Click the [Scan] button. The document data is scanned.

Useful Sending Method

You can specify the following useful scanning (sending) methods.

WSD Scan

Saves images of originals scanned on this machine as files on a WSD-compatible computer.

➔ [Executing WSD scan \(page 244\)](#)

Scanning using the fax server

You can send a scanned document via a fax server.

➔ [Using a Fax Server to Send \(Fax Server Send\) \(page 248\)](#)

Sending to different types of destinations (Multi sending)

Sends to different types of destination (E-mail addresses, folders, etc.) in a single operation.

➔ [Sending to different types of destinations \(Multi sending\) \(page 245\)](#)

Send to Me (Email)

Sends to the E-mail address of the logged in user when user login is enabled.

➔ [Sending Documents to E-mail Address of Logged in User \(to myself\) \(page 247\)](#)

WSD Scan

WSD Scan saves images of originals scanned on this machine as files on a WSD-compatible computer.



NOTE

- To use WSD Scan, confirm that the computer used for WSD scanning and the machine is network-connected, and [WSD-SCAN] is set to [OnOn] in the network settings.
 - ➔ [WSD-SCAN \(page 397\)](#)
 - For information on operating the computer, refer to the computer's help or the operation guide of your software.
 - When transmitting using wireless LAN, select the interface dedicated to the send function in advance.
 - ➔ [\[Primary Network\] \(page 404\)](#)
-

Install the Driver (for Windows 10)

1 Right-click the Windows [Control Panel] button and select [Start] → [Devices and Printers].

2 Install the driver.

Click [Add a device]. Select the icon that displays the machine model name, and click [Next].

When the machine model icon is displayed as a "Printer" on the "Devices and Printers" screen, installation is complete.

Install the Driver (for Windows 11)

1 Click the Windows [Start] button → [All apps] → [Windows Tools] → [Control Panel] → [Devices and Printers].

2 **Install the driver.**

Click [Add a device]. Select the icon that displays the machine model name, and click [Next].

When the machine model icon is displayed as a "Printer" on the "Devices and Printers" screen, installation is complete.

Executing WSD scan

WSD Scan saves images of originals scanned on this machine as files on a WSD-compatible computer.

1 Select the key

2 Load paper.

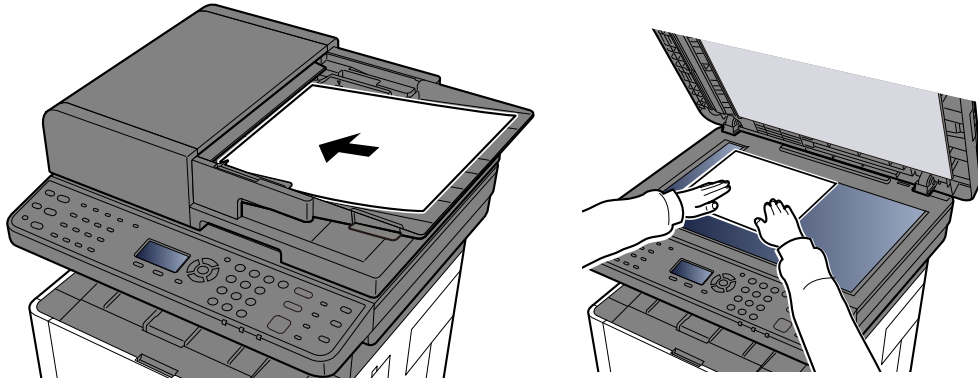

➔ [Loading Originals \(page 221\)](#)

3 Display the screen

[▲][▼] keys > [WSD Scan] > [OK] key

4 Scan the originals.

For procedure with scanning using this machine, refer to step 4 in 1 step.

For procedure from your computer, refer to step 6 in step 5.

1 [▲][▼] keys > [From Oper. Panel] > [OK] key

2 Select the destination computer, and select the [OK] key.

You can view information on the selected computer by selecting [Detail].

3 Select the [Function Menu] key and configure the settings for functions.

4 Press the [Start] key.

WSD compatible software installed on the computer starts during sending, and when sending is completed, the file can be confirmed.

5 [▲][▼] keys > [From Computer] > [OK] key

6 Use the software installed on the computer to send the images.

Sending to different types of destinations (Multi sending)

You can specify destinations combining E-mail addresses, folders (SMB or FTP), and fax numbers. This is referred to as Multi Sending. This is useful for sending to different types of destination (E-mail addresses, folders, etc.) in a single operation.

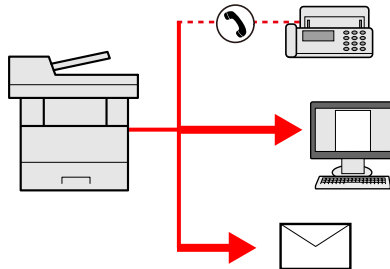

No. of broadcast items: Up to 5050

However, number of items are restricted for the following sending options.

- E-mail and fax: Up to 100100 in total
- Folders (SMB, FTP): Total of 55 SMB and FTP

Also, depending on the settings, you can send and print at the same time.

Procedures are the same as used in specifying the destinations of respective types. Continue to enter E-mail address or folder path so that they appear in the destination list. Press the key to start transmission to all destinations at one time.

NOTE

- If the destinations include a fax, the images sent to all destinations will be black and white.
- If is set to , multiple destinations cannot be entered.

Sending to different types of destinations

1 Select the [Send] key

2 Load paper.

3 Specify the recipient.

4 Configure the settings

Select the [Function Menu] key and set the sending function to use.

5 Press the key.



When selecting On for "Destination Check before Send", the confirmation screen appears.

➔ [Confirmation Screen of Destinations \(page 256\)](#)

6 Press the key.



A confirmation prompt is displayed on the screen. After confirming the message, select [Next] and press the [Start] key.

Sending starts.

Sending Documents to E-mail Address of Logged in User (to myself)

Sends to the E-mail address of the logged in user when user login is enabled.

1 Configure the settings.

Before using this function, an E-mail address must be set in user login for the user who logs in.

→ [Adding a User \(Local User List\) \(page 487\)](#)



NOTE

When this function is used, functions other than transmission cannot be used.

2 [Send] key > [▲] [▼] keys > [Me(E-mail)] > [OK] key

Using a Fax Server to Send (Fax Server Send)

You can send a scanned document via a fax server.

NOTE

- A fax server is required to use this function. For information about the fax server, contact the applicable administrator.
- FAX server settings must be configured to send a FAX. For details, refer to the following:
 - ➔ **Command Center RX User Guide**
 - ➔ [\[FAX Server Set.\] \(page 413\)](#)

1 Select the [Send] key

2 Load paper.

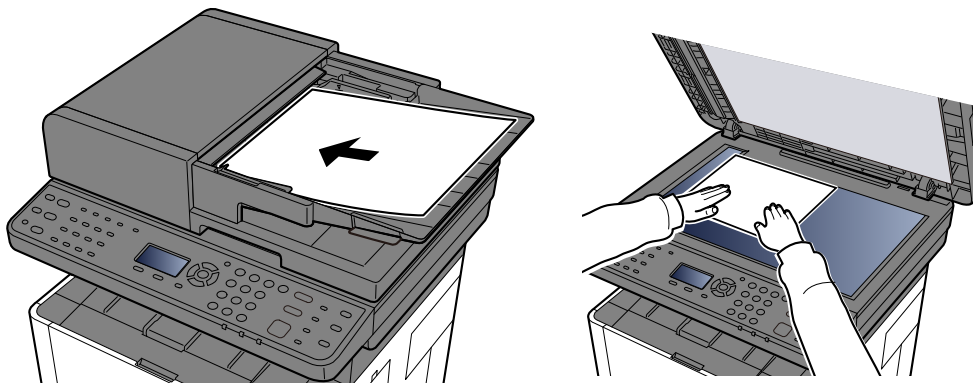

➔ [Loading Originals \(page 221\)](#)

3 [▲][▼] keys > [FAX Server] > [OK] key

4 Enter the recipient information.

When entering directly

- 1 [▲][▼] keys > [FAX No. Entry] > [OK] key
- 2 Enter the fax number > [OK]

NOTE

- Use the numeric keys to enter a number.
- When selecting [On] for [Check New Dest.], the re-entering screen for the destination information appears.

➔ [Re-entering the New Destination \(page 257\)](#)

Destinations can be changed later.

5 Checking and Editing Destinations

➔ [Checking and Editing Destinations \(page 255\)](#)



NOTE

When selecting the information from the Address Book, select [Address Book], and select the [Destination] > [OK] key.

➔ [Choosing from the Address Book \(page 252\)](#)



NOTE

When selecting the information from the External Address Book, select [Ext Address Book], and select the [Destination] > [OK] key.

For details on the External Address Book, refer to the following:

➔ [Accessing Command Center RX \(page 113\)](#)

6 Configure the settings

Select the [Function Menu] key and set the sending function to use.

➔ [Send \(page 280\)](#)

7 Press the [Start] key.



NOTE

When selecting [Check beforeSend], the confirmation screen appears.

➔ [Confirmation Screen of Destinations \(page 256\)](#)

8 Press the [Start] key.



NOTE

A confirmation prompt is displayed on the screen if more than one destination is specified. After confirming the message, select [Next] and press the [Start] key. Sending starts.

Canceling Sending Jobs

1 Select the [Stop] key with the send screen displayed.

The [Job Cancel List] screen is displayed.

NOTE

Selecting the [Stop] key will not temporarily stop a job that you have already started sending.

2 Cancel a job.

1 [▲] [▼] keys > [Cancel Send Job] > [OK] key

2 Select the job to cancel, and select [Menu].

3 [▲] [▼] keys > [Cancel Job] > [OK] key

NOTE

Select [Detail], and the [OK] key and detailed information of the job is displayed.

4 Select [Yes].

The job is canceled.

NOTE

A job in the middle of scanning can be canceled by selecting the [Stop] key or [Cancel].

Handling Destination

This section explains how to select and confirm the destination.

Specifying Destination

Select the destination using either of the following methods except entering address directly:

- Choosing from the Address Book
 - ➔ [Choosing from the Address Book \(page 252\)](#)
- Choosing from the External Address Book
 - For details on the External Address Book, refer to the following:
 - ➔ **Command Center RX User Guide**
- Choosing from One Touch key destinations
 - ➔ [Choosing from One Touch key destinations \(page 254\)](#)
- Choosing from the FAX
 - Fax function is available for fax models.
 - ➔ **FAX Operation Guide**

NOTE

- You can set the machine up so that the address book screen appears when you select the [Send] key.
 - ➔ [Default Screen \(page 427\)](#)
 - If you are using the products equipped with the fax function, you can specify the fax destination. Enter the other party number using the numeric keypad.
-

Choosing from the Address Book

For more information about how to register destinations in the Address Book, refer to the following:

➔ [Registering Destinations in the Address Book \(page 161\)](#)

1 In the basic screen for sending, select [Address Book] key

2 Select the destinations.

- 1 [▲] [▼] keys > [Address Book] > [OK] key



NOTE

For details on the External Address Book, refer to the following:

➔ [Command Center RX User Guide](#)

- 2 Specify the destination.



NOTE

To check detailed information about the selected destination, press [Menu] > [Detail] > [OK] key

3 Enter the recipient information.

Destinations registered in the Address Book can be searched.

- 1 [Menu] > [▲] [▼] keys > [Search(Furigana)] > [OK] key
- 2 Use the numeric keys to enter a number.



IMPORTANT

For details on entering characters, refer to the following:

➔ [Character Entry \(page 761\)](#)

- 3 Select the [OK] key.
The searched destination is displayed.

4 Select the [OK] key

To add the destination, repeat steps 1-4. Up to 100 E-mail addresses can be sent.

Destinations can be changed later.

➔ [Checking and Editing Destinations \(page 255\)](#)

Choosing from the External Address Book

NOTE

For details on the External Addresses, refer to the following:

➔ [Command Center RX User Guide](#)

1 Display the screen

- 1 In the basic screen for sending, select [Address Book] key > [Menu] > [▲][▼] keys > [Switch Address Book] > [OK] key
- 2 [▲][▼] keys > Select Extended Address > [OK] key

2 Select the destinations.

- 1 Specify the destination.

NOTE

To check detailed information about the selected destination, press [Menu] > [Detail] > [OK] key

3 Enter the recipient information.

A destination can be searched for by Name.

- 1 [Menu] > [▲][▼] key > [Search(Furigana)] > [OK] key
- 2 Use the numeric keys to enter a number.

For details on entering characters, refer to the following:

➔ [Character Entry \(page 761\)](#)

4 Select the [OK] key

To add the destination, repeat steps 1-4. Up to 100 E-mail addresses can be sent. Destinations can be changed later.

➔ [Checking and Editing Destinations \(page 255\)](#)

Choosing from One Touch key destinations

In the basic screen for sending, select the One Touch Keys where the destination is registered.

 **NOTE**

This procedure assumes that One Touch Keys have already been registered.

For more information on adding One Touch keys, refer to the following:

➔ [Add One Touch Keys. \(page 172\)](#)

To select one-touch keys 12 to 22, you must select the [Shift lock] key to light the [Shift lock] lamp, and then select the one-touch key.

Destinations can be changed later.

➔ [Checking and Editing Destinations \(page 255\)](#)

Checking and Editing Destinations

1 Display the screen

Specify the destination.

➔ [Specifying Destination \(page 251\)](#)

2 Check and edit the destination.

Select the [Destination] key.

Enter the recipient information.

1 Select [Add].

2 Select the destination you wish to add, and select the [OK] key.

➔ [Specifying Destination \(page 251\)](#)

Edit a contact address.

1 Select the destination you wish to change, and select the [OK] key.

2 [▲] [▼] keys > [Detail/Edit] > [OK] key

3 Edit Destination > [OK] key

➔ [Specifying Destination \(page 251\)](#)



NOTE

For more information on changing destinations registered in the address book or One Touch keys, refer to the following:

➔ [Editing Contact Address in Address Book \(page 169\)](#)

➔ [Editing the Destination to the One Touch Key \(page 172\)](#)

Delete destination

1 Select the destination you wish to delete, and select the [OK] key.

2 [▲] [▼] keys > [Delete] > [OK] key > "Yes "

3 Select [Exit]



NOTE

If [Check beforeSend] is set to [OnOn], the confirmation screen appears when the [Start] key is pressed.

➔ [Check beforeSend \(page 470\)](#)

➔ [Confirmation Screen of Destinations \(page 256\)](#)

Confirmation Screen of Destinations

When "Check beforeSend" is set to [On], the confirmation screen of destinations appears after pressing the [Start] key.

→ [Check beforeSend \(page 470\)](#)

1 Confirmation Screen of Destinations

To view detailed information about a destination, select the destination and press [OK] key > [▲][▼] keys > [Detail] > [OK] key

If you want to delete a destination, select the destination and press [OK] key > [▲][▼] keys > [Delete] > [OK] key > [Yes]

The destination is deleted.

2 Select [Next].



NOTE

Be sure to confirm all destination by displaying them on the touch panel. You cannot select [Next] unless you have confirmed all destination.

Re-entering the New Destination

When selecting On for "Check New Dest.", the re-entering screen for the destination information appears.

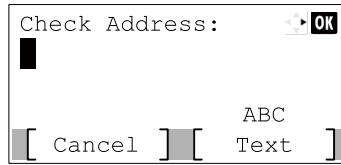

Enter the same destination information again, and select the [OK] key.

Recall

I tried sending a message, but the other party did not respond. I want to send it to the same destination again. In such a case, by selecting the [Address Recall/Pause] key, you can recall the most recently sent destination to the destination list.

1 Select the [Address Recall/Pause] key

The previous destination is displayed on the destination list.



NOTE

When the last sending included FAX, folders and E-mail destinations, they are also displayed. If necessary, add or delete the destination.

2 Press the [Start] key.

Sending starts.



NOTE

- If "Check beforeSend" is set to "On", the destination confirmation screen appears when the [Start] key is pressed.
 - ➔ [Confirmation Screen of Destinations \(page 256\)](#)
 - Recall information is canceled in the following conditions.
 - When you turn the power off
 - When you send a next image (new recall information is registered)
 - When you log out
-

How to use the FAX Function

On products with a FAX function, it is possible to use the FAX function.

Fax function is available for fax models.

➔ **FAX Operation Guide**

Using Document Boxes

Document Box is a function for saving print data from a computer and sharing it with multiple users. The following types of document boxes are available:

- Job Box
- USB Drive Box
- Fax Memory RX Box (only for fax-compatible models)
- Subaddress Communication Box (only for fax-compatible models)
- Polling Box (only for fax-compatible models)

What is Job Box?

Job Box is a generic name for the "Private Print/Stored Job Box", "Quick Copy/Proof and Hold Box", and "PIN Print Box".

These Job Boxes cannot be created or deleted by a user.



NOTE

- An SD/SDHC Memory Card is required to use the Stored Job Box and the Quick Copy Box.
- You can set up the machine so that temporary documents in job boxes are automatically deleted.
➔ [JobRet. Deletion \(page 474\)](#)
- For details on operating the "Private Print/Job Hold Box", "Quick Copy/Proof and Hold Box", or "PIN Print Box", refer to the following:
➔ [Printing Data Saved in the Printer \(page 193\)](#)



IMPORTANT

SD/SDHC memory cards store unencrypted data. Please be careful when storing sensitive documents.

What is USB Drive Box?

A USB drive can be connected to the USB drive slot on the machine to print a saved file. You can print data directly from the USB drive without a PC.

Image files scanned using this machine can also be saved to USB drive in the PDF, TIFF, JPEG, XPS, OpenXPS, or high compression PDF format (Scan to USB).

What is a Fax Memory RX Box/Subaddress Box/Polling Box?

Fax Box store the fax data.

Fax function is available for fax models.

For details, refer to the following:

➔ **FAX Operation Guide**

Using Removable USB Drive

Plugging USB drive directly into the machine enables you to quickly and easily print the files stored in the USB drive without having to use a computer.

The following file types can be printed:

- PDF file (Version 1.7/2.0 or older)
- TIFF file (TIFF V6/TTN2 format)
- JPEG file
- XPS file
- OpenXPS file
- Encrypted PDF file

In addition, you can store scanned image files in USB drive connected to the machine. The following file formats can be stored:

- PDF file
- TIFF file
- JPEG file
- XPS file
- OpenXPS file
- High-compression PDF file format

Printing Documents Stored in Removable USB Drive

NOTE

- PDF files you wish to print should have an extension (.pdf).
 - Use USB drive properly formatted by this machine.
 - Plug the USB drive directly into the USB Drive Slot.
-

1 Insert the USB drive

Plug the USB drive into the USB Drive Slot.

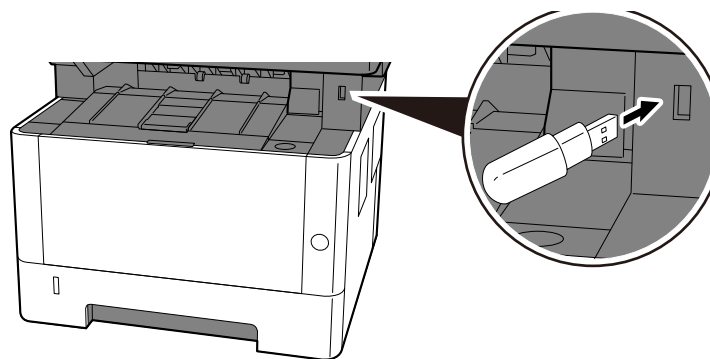

2 Display the screen

[Document Box/USB] key > [▲][▼] keys > [USB Drive] > [OK] key

3 Print the document.

- 1 Select the folder containing the file to be printed and select the [OK] key.
You can display up to the third level, including the root directory.



NOTE

- 1,000 documents can be displayed.
 - To return to a higher level folder, select [Back].
-

- 2 Select the document you wish to print and select [Select] key.
Select a document and a checkmark will appear on the right side of the selected document.
If you select a document marked with a checkmark and once again select [Select], the selection will be cleared.



NOTE

If you select [Menu], you can perform the following operations.

- [Select All]: Select all documents.
 - [Clear All]: Deselect all documents.
 - [Detail]: Display the details for the selected document.
 - [USB Drive Detail]: Display the details of the USB device.
 - [Remove USB Drive]: Remove the USB memory.
-

- 3 [OK] key > [▲][▼] keys > [Print] > [OK] key
- 4 Change the number of copies, duplex printing, etc. as desired.
For the functions that can be set, refer to the following:
➔ [USB Drive \(Store File, Printing Documents\) \(page 283\)](#)
- 5 Press the [Start] key.
Printing of the selected document begins.

Saving Documents to USB Drive (Scan to USB)

You can store scanned documents to a removal USB drive.

NOTE

The maximum number of the storable files is 1,000.

1 Load paper.

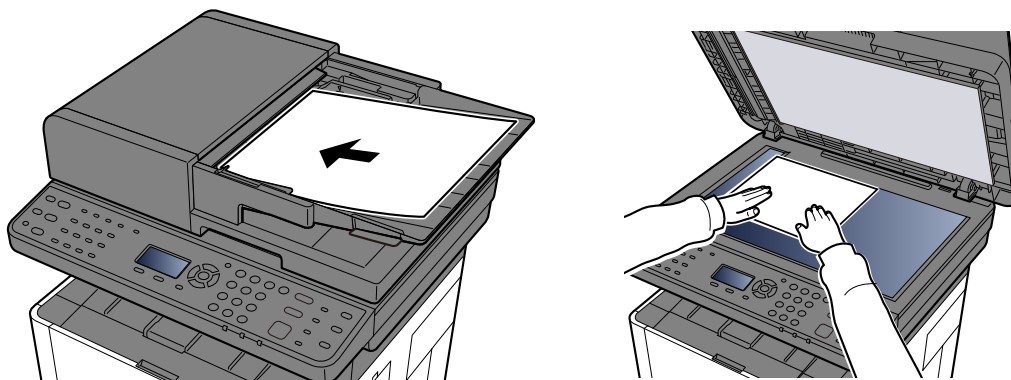

➔ [Loading Originals \(page 221\)](#)

2 Insert the USB Drive

Plug the USB drive into the USB Drive Slot.

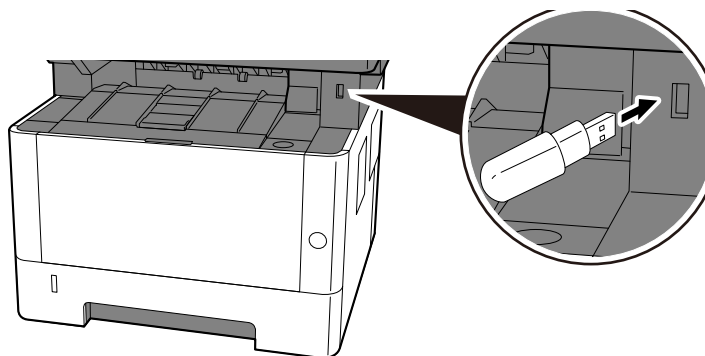

3 Display the screen

[Document Box/USB] key > [▲][▼] keys > [USB Drive] > [OK] key

4 Store the document.

- 1 Select the folder where the file will be stored, and select the [OK] key.
You can display up to the third level, including the root directory.
- 2 [▲][▼] keys > [Store File] > [OK] key
- 3 Set the type of original, file format, etc., as desired.
For the functions that can be set, refer to the following:
➔ [USB Drive \(Store File, Printing Documents\) \(page 283\)](#)
- 4 Press the [Start] key.
The original is scanned and the data is stored in the USB drive.

Check the USB Drive Information

1 Display the screen

[Document Box/USB] key > [▲] [▼] keys > [USB Drive] > [OK] key > [Menu] > [▲] [▼] keys > [USB Drive Detail] > [OK] key

2 Check the information.

Select the [▶] key to display the next page. Select the [◀] key to return to the previous page. Confirm the information and select the [OK] key.

Removing USB Drive

 **IMPORTANT**

Be sure to follow the proper procedure to avoid damaging the data or USB drive.

1 Display the screen

[Reset] key > [▲][▼] keys > [USB Drive] > [OK] key

2 Select Remove.

[Menu] key > [▲][▼] keys > [Remove USB Drive] > [OK] key

3 Removing USB Drive

When "USB Drive can be safely removed. " is displayed, select [OK] then remove the USB drive.



NOTE

USB drive can also be removed via Device Status Confirmation.

➔ [Check the device information \(page 363\)](#)

Cloud Linkage Function

Use Kyocera Cloud Access to link the cloud service (Google Drive) this machine. You can save scanned documents to a folder in the cloud service and print files in the cloud service.

Access the cloud service in advance, upload the file you want to print, and create a destination folder.

This section explains procedures for individual users who do not need administrator rights to use the cloud integration function as an example. The action is as follows:

- 1 Set up files and folders in a cloud service.**
- 2 Install Kyocera Cloud Access.**
- 3 Set Kyocera Cloud Access user account (authentication information).**
- 4 Link with the cloud service.**
- 5 Scan and print through the cloud service.**



NOTE

For procedures for users who require administrator privileges to use the cloud linkage function, refer to the following:

➔ [Kyocera Cloud Access User Guide](#)

Set up files and folders in a cloud service.

Before using the cloud linkage function, please do the following preparations in the cloud service:

- 1 Upload the file you want to print.**
- 2 Create a destination folder.**

Installing Kyocera Cloud Access

 **IMPORTANT**

Depending on the usage environment, the installation may take some time to complete. Do not force a termination during the installation.

1 Downloading Installer

➔ [Downloading and installing from the website \(page 89\)](#)

2 Click the installer.

The installer will start up.

3 Select the setup language > [OK]

4 Scroll and confirm the license agreement and select [Accept] > [Next].

5 Select [Next] in the "Information" screen.

The "Information" screen displays additional components that will be installed on the computer.

6 Select [Next] without checking [Manage settings as an administrator].



NOTE

To manage Kyocera Cloud Access as an administrator for your organization or team, select this setting.

➔ [Kyocera Cloud Access User Guide](#)

7 Select [Install].

Installation of the application begins.

8 Select [Restart computer now], then select [Finish].

Set Kyocera Cloud Access user account (authorization information).

Set the Kyocera Cloud Access user authorization information to link with the cloud.

1 Double-click the Kyocera Cloud Access icon.

The browser launches and the Kyocera Cloud Access setup screen appears.



NOTE

You can also display the setup screen by entering the following URL in a browser.

<https://kyoceracloudaccess.com:11022/>

2 Select [Start].

3 Set Kyocera Cloud Access account (authorization information).

Enter the following information:

- User Name
- Name
- E-mail Address
- Password



NOTE

Enter a new security password of 8 or more characters and symbols. You can include symbols.

4 Select [Generate PIN].

A 6-digit PIN code will be generated, so please write it down.

5 Select a question from the [Security Question] drop-down list and enter your answer.

This information is used to verify the user identity and recover the password.

6 Select [Next].

Advances to the proxy setting screen.

7 Enter the address and port of the proxy server > [Next]

Check it from your browser. If you do not know them, please contact your provider.



NOTE

The same username and password as those set in the previous step are displayed.

- 8 Confirm the printer that you want to link with the cloud service, and select [Connect].**
- 9 Select [Finish] and then "Sign in".**

Linkage with the Cloud Service

Link Kyocera Cloud Access account with the cloud service and set up the folders and files you want to use.

- 1** Select **[Add]** in the **"Linked Cloud Service Account"** screen.
- 2** Select **[Google Drive]** in the **"Select your cloud service"** screen.
- 3** Select **[Connect to Google]**.
- 4** On the **"Sign in"** screen, select the user (e-mail address) of the cloud service.
- 5** Enter the password > **[Next]** > **[Continue]**
Go to the screen to link with the cloud service to be used.
- 6** Select **[Set up folders and files]**.
- 7** Select **[Add folder]**.
- 8** Select the destination folder for scanned data created on the cloud service > **[Select]** > **[Next]**
- 9** Select the file you want to print from the files uploaded to the cloud service > **[Select]**



NOTE

- Printable file formats are JPEG, PDF, and TIFF.
 - To print multiple files, select them while pressing and holding **[Shift]**.
-

10 Confirm that printable files are displayed > **[Finish]**



NOTE

You can add, edit, and delete scanned folders and printable files. Select **[Home]**, and then select **[Setup]** of the email address. Select "Scan Destinations" and "Printable Files" tabs, set them, and then select **[Save]**.

This completes the operation of the cloud service linkage in Kyocera Cloud Access. Next, use the operation panel to link this machine with the cloud service via the Kyocera Cloud Access and perform scan/print operations.

Scan and Print using the Cloud Service

Print a file on the cloud service

1 Display the screen

If [Cloud Access] is displayed on the Home screen, this step is not necessary.

- 1 [System Menu/Counter] key > [▲][▼] keys > [Common Settings] > [OK] key > [▲][▼] keys > [Cloud Access Setting] > [OK] key



NOTE

If the user authentication screen appears, log in with a user who has the privilege to configure this setting. If you do not know your login user name or password, please contact your administrator.

- 2 [Cloud Access] > [▲][▼] key > [On] > [OK] key
- 3 [Interface Settings] > [▲][▼] keys > [Connection List] > [OK] key > [▲][▼] keys > [Off] > [OK] key

2 Log in to the cloud service from this machine

- 1 [Document Box/USB] key > [▲][▼] keys > [Cloud Access] > [OK] key

The connection list appears.

- 2 [▲][▼] key > Select a connection name from the connection list > [OK] key
- 3 Enter your user ID and password to connect to [Cloud Access] > [Login]



NOTE

You can also select [Menu] > [▲][▼] keys > [PIN Login] and enter the PIN code created when you set up Kyocera Cloud Access account.

3 Print a file in Google Drive

- 1 [Google Drive] > [OK]
- 2 In the search screen, search for the file you want to print.



NOTE

Entering a part of the name and selecting [OK] displays the applicable folder or file.

- 3 Select file to print > [Menu] > [▲][▼] keys > [Print] > [OK]
- 4 [Function Menu] key > Select and set print functions as needed > [Exit]

4 Press the [Start] key.

Printing begins.

Scan and send files to the cloud service

1 Display the screen

If [Cloud Access] is displayed on the Home screen, this step is not necessary.

- 1 [System Menu/Counter] key > [▲][▼] keys > [Common Settings] > [OK] key > [▲][▼] keys > [Cloud Access Setting] > [OK] key

 **NOTE**

If the user authentication screen appears, log in with a user who has the privilege to configure this setting. If you do not know your login user name or password, please contact your administrator.

- 2 [Cloud Access] > [▲][▼] key > [On] > [OK] key
- 3 [Interface Settings] > [▲][▼] keys > [Connection List] > [OK] key > [▲][▼] keys > [Off] > [OK] key

2 Log in to the cloud service from this machine

- 1 [Document Box/USB] key > [▲][▼] keys > [Cloud Access] > [OK] key

The connection list appears.

- 2 [▲][▼]key > Select a connection name from the connection list > [OK] key
- 3 Enter your user ID and password to connect to Cloud Access > [Login]

 **NOTE**

You can also select [Menu] > [▲][▼] keys > [PIN Login] and enter the PIN code created when you set up Kyocera Cloud Access account.

3 Send a file to a folder in Google Drive

- 1 [Google Drive] > [OK]

 **NOTE**

You can search for the target folder on the search screen.

- 2 Select the file to send > [Menu] > [Send]
- 3 Select and set send functions as needed.

4 Press the [Start] key.

Sending starts.

6 Using Various Functions

About Functions Available on the Machine

This machine provides the various functions available.

Select a function menu.

Select the [Function Menu] key will allow you to configure the settings for functions.

➔ [Select a function menu. \(page 277\)](#)

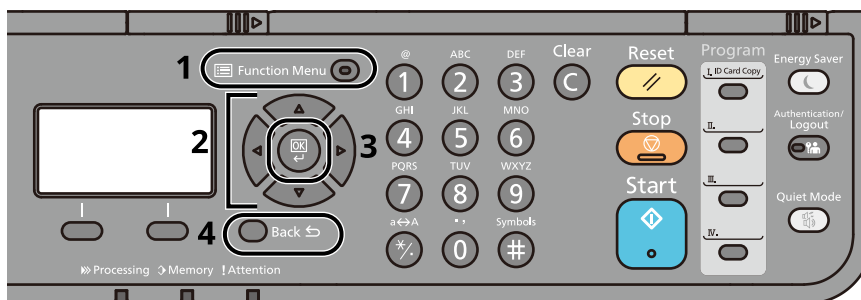

- 1 Display the function menu.
- 2 Select the displayed item or change the value.
- 3 Confirm the selected settings.
- 4 Cancels the current settings and returns to the next level up.

Copy

For details on each function, see the table below.

Function	Description
[Paper Selection]	Select the cassette or multipurpose tray that contains the required paper size. ➔ Paper Selection (page 287)
[Collate]	Prints the output by page or set. ➔ Collate (page 292)
[ID Card Copy]	Use this when you want to copy a driver's license or an insurance card. When you scan the front and back of the card, both sides will be combined and copied onto a single sheet. ➔ ID Card Copy (page 293)
[Duplex]	Produces two-sided copies. You can also create single-sided copies from two-sided originals. ➔ Duplex (When copying) (page 315)
[Zoom]	Adjust the zoom to reduce or enlarge the image. ➔ Zoom (When copying) (page 305)
[Combine]	Combines 2 or 4 original sheets into 1 printed page. ➔ Combine (page 308)
[Border Erase]	Erases the black borders that form around the image. ➔ Border Erase (page 311)
[Original Size]	Specify the original size to be scanned. ➔ Original Size (page 286)
[Orig.Orientation]	Select the orientation of the original document top edge to scan correct direction. ➔ Orig.Orientation (page 291)
[Mixed Size Orig.]	Scan the documents of different sizes that are set in the document processor all at once. ➔ Mixed Size Orig. (page 289)
[Original Image]	Select original image type for best results. ➔ Original Image (page 295)
[Density]	Adjust density. ➔ Density (page 294)
[EcoPrint]	EcoPrint saves toner when printing. ➔ EcoPrint (page 297)
[Continuous Scan]	Scans a large number of originals in separate batches and then produces as one job. ➔ Continuous Scan (page 318)
[File Name Entry]	Name a document. ➔ File Name Entry (page 320)

Function	Description
[JobFinish Notice]	Sends E-mail notice when a job is complete. ➔ JobFinish Notice (page 319)
[Print Override]	Suspends the current job and gives a new job top priority. ➔ Priority Override (page 321)
[Sharpness]	Adjusts the sharpness of image outlines. ➔ Sharpness (page 299)
[Contrast]	You can adjust the contrast between light and dark areas of the image. ➔ Contrast (page 303)
[Backgrnd Density]	Removes dark background from originals, such as newspapers. ➔ Backgrnd Density (page 300)
[Prevent Bleed-t]	Hides background colors and image bleed-through when scanning thin original. ➔ Prevent Bleed-t (page 302)
[Erase Colors]	Erases colors in the source document. ➔ Erase Colors (page 304)
[Skip Blank Page]	When there are blank pages in a scanned document, this function skips the blank pages and prints only pages that are not blank. ➔ Skip Blank Page (page 323)

Send

For details on each function, see the table below.

Function	Description
[Color Selection]	Select the color setting. ➔ Color Selection (page 298)
[Original Size]	Specify the original size to be scanned. ➔ Original Size (page 286)
[Original Image]	Select original image type for best results. ➔ Original Image (page 295)
[Scan Resolution]	Select fineness of scanning resolution. ➔ Scan Resolution (page 335)
[Sending Size]	Select size of image to be sent. ➔ Sending Size Sending Size (page 325)
[Border Erase]	Erases the black borders that form around the image. ➔ Border Erase (page 311)
[Zoom]	Adjust the zoom to reduce or enlarge the image. ➔ Zoom (When printing/sending/storing) (page 307)
[Orig.Orientation]	Select the orientation of the original document top edge to scan correct direction. ➔ Orig.Orientation (page 291)
[Mixed Size Orig.]	Scan the documents of different sizes that are set in the document processor all at once. ➔ Mixed Size Orig. (page 289)
[Continuous Scan]	Scans a large number of originals in separate batches and then produces as one job. ➔ Continuous Scan (page 318)
[File Format]	Specify the image file format. Image quality level can also be adjusted. ➔ File Format (page 327)
[File Name Entry]	Name a document. ➔ File Name Entry (page 320)
[Subject]	Adds subject and body when sending a document. ➔ Subject/Body (page 337)
[JobFinish Notice]	Sends E-mail notice when a job is complete. ➔ JobFinish Notice (page 319)
[FAX Resolution]	Select fineness of images when sending FAX. Displays only for fax models. ➔ FAX Operation Guide

Function	Description
[FAX Delayed TX]	Set a send time. Displays only for fax models. ➔ FAX Operation Guide
[FAX Direct TX]	Sends FAX directly without reading original data into memory. Displays only for fax models. ➔ FAX Operation Guide
[FAX RX Polling]	Dial the destination and receive documents for Polling Transmission stored in the polling box. Displays only for fax models. ➔ FAX Operation Guide
[FAX TX Report]	Print a report of fax transmission results. This item is displayed for fax-compatible machines. ➔ FAX Operation Guide
[Density]	Adjust density. ➔ Density (page 294)
[Clarify Text]	When scanning and sending a document in black and white, it eliminates background noise and improves the legibility of the text. ➔ Clarify Text (Noise Removal) (page 336)
[Duplex]	Select the type and orientation of the binding based on the original. ➔ Duplex (page 324)
[FTP Encrypted TX]	Encrypts images when sending via FTP. ➔ FTP Encrypted TX (page 338)
[File Separation]	Creates a file for each scanned original data page and sends the files. ➔ File Separation (page 334)
[Sharpness]	Adjusts the sharpness of image outlines. ➔ Sharpness (page 299)
[Contrast]	You can adjust the contrast between light and dark areas of the image. ➔ Contrast (page 303)
[Backgrnd Density]	Removes dark background from originals, such as newspapers. ➔ Backgrnd Density (page 300)
[Saturation]	Adjust the color saturation of the image. ➔ Saturation (page 301)
[Prevent Bleed-t]	Hides background colors and image bleed-through when scanning thin original. ➔ Prevent Bleed-t (page 302)
[Erase Colors]	Erases colors in the source document. ➔ Erase Colors (page 304)

Function	Description
[FoldingDetection]	When scanning a document from the document processor, scanning is automatically stopped when a document with a folded corner is detected. ➔ FoldingDetection (page 322)
[Skip Blank Page]	When there are blank pages in a scanned document, this function skips the blank pages and sends only pages that are not blank. ➔ Skip Blank Page (page 323)
[EmailEncryptedTX]	Sends encrypted E-mail using the electronic certificate. ➔ EmailEncryptedTX (page 339)
[DigitalSignature]	Add a digital signature to the email, using the electronic certificate. ➔ DigitalSignature (page 340)

USB Drive (Store File, Printing Documents)

For details on each function, see below:

➔ [USB Drive \(Store File\) \(page 283\)](#)

➔ [USB Drive \(Printing Documents\) \(page 285\)](#)

USB Drive (Store File)

For details on each function, see the table below.

Function	Description
[Color Selection]	Select the color setting. ➔ Color Selection (page 298)
[Original Size]	Specify the original size to be scanned. ➔ Original Size (page 286)
[Original Image]	Select original image type for best results. ➔ Original Image (page 295)
[Scan Resolution]	Select fineness of scanning resolution. ➔ Scan Resolution (page 335)
[Storing Size]	Select size of image to be stored. ➔ Storing Size (page 342)
[Border Erase]	Erases the black borders that form around the image. ➔ Border Erase (page 311)
[Zoom]	Adjust the zoom to reduce or enlarge the image. ➔ Zoom (When printing/sending/storing) (page 307)
[Orig.Orientation]	Select the orientation of the original document top edge to scan correct direction. ➔ Orig.Orientation (page 291)
[Mixed Size Orig.]	Scan the documents of different sizes that are set in the document processor all at once. ➔ Mixed Size Orig. (page 289)
[Continuous Scan]	Scans a large number of originals in separate batches and then produces as one job. ➔ Continuous Scan (page 318)
[File Format]	Specify the image file format. Image quality level can also be adjusted. ➔ File Format (page 327)
[File Separation]	Creates a file for each scanned original data page and sends the files. ➔ File Separation (page 334)
[File Name Entry]	Name a document. ➔ File Name Entry (page 320)
[JobFinish Notice]	Sends E-mail notice when a job is complete. ➔ JobFinish Notice (page 319)

Function	Description
[Density]	Adjust density. ➔ Density (page 294)
[Clarify Text]	When scanning and sending a document in black and white, it eliminates background noise and improves the legibility of the text. ➔ Clarify Text (Noise Removal) (page 336)
[Duplex]	Select the type and orientation of the binding based on the original. ➔ Duplex (page 324)
[Sharpness]	Adjusts the sharpness of image outlines. ➔ Sharpness (page 299)
[Contrast]	You can adjust the contrast between light and dark areas of the image. ➔ Contrast (page 303)
[Backgrnd Density]	Erases colors in the source document. ➔ Erase Colors (page 304)
[Saturation]	Adjust the color saturation of the image. ➔ Saturation (page 301)
[Prevent Bleed-t]	Hides background colors and image bleed-through when scanning thin original. ➔ Prevent Bleed-t (page 302)
[Erase Colors]	Erases colors in the source document. ➔ Erase Colors (page 304)
[Skip Blank Page]	When there are blank pages in a scanned document, this function skips the blank pages and stores only pages that are not blank. ➔ Skip Blank Page (page 323)

USB Drive (Printing Documents)

Function	Description
[Paper Selection]	Select the cassette or multipurpose tray that contains the required paper size. ➔ Paper Selection (page 287)
[Collate]	Prints the output by page or set. ➔ Collate (page 292)
[Duplex]	Print a document to 1-side or 2-sides. ➔ Duplex (USB drive) (page 317)
[File Name Entry]	Name a document. ➔ File Name Entry (page 320)
[JobFinish Notice]	Sends E-mail notice when a job is complete. ➔ JobFinish Notice (page 319)
[EcoPrint]	EcoPrint saves toner when printing. ➔ EcoPrint (page 297)
[Print Override]	Suspends the current job and gives a new job top priority. ➔ Priority Override (page 321)
[Encrypted PDF]	Enter the password you set to print the PDF data. ➔ Encrypted PDF (page 343)
[JPEG/TIFF Print]	Select the image size when printing JPEG or TIFF files. ➔ JPEG/TIFF Print (page 344)
[XPS FitTo Page]	Reduces or enlarges the image size to fit to the selected paper size when printing XPS file. ➔ XPS FitTo Page (page 345)

Functions

On pages that explain a convenient function, the modes in which that function can be used are indicated by icons.



Original Size



Specify the original size to be scanned.

Value	Description
Auto (standard size) ^{*1} , Auto (non-standard size), A4, A5, A6, B5, B6, Letter, Legal, Statement, Executive, Oficio II, Folio, 216 × 340 mm, 16K, ISO B5, Envelope #10, Envelope #9, Envelope #6, Envelope Monarch, Envelope DL, Envelope C5, postcard, return postcard, Youkei 4, Youkei 2, Nagagata 3, Nagagata 4, Younaga 3, Custom ^{*2}	Select from standard sizes and custom sizes.

*1: It is displayed when [Detect Std.Size] of [Common Settings] > [Orig./Paper Set.] > [Detect Orig.(DP)] > [Auto Detect] is set to [On].

→ [Detect Std.Size \(page 433\)](#)

*2: It can only be placed in the document processor.

NOTE

Be sure to always specify the original size when using custom size original.

Paper Selection



Select the cassette or multipurpose tray that contains the required paper size. If [Auto] is selected, paper the same size as the original is automatically selected.

NOTE

- Specify in advance the size and type of the paper loaded in the cassette.
 - ➔ [\[Orig./Paper Set.\] \(page 432\)](#)
- Cassettes after Cassette 2 are displayed when the optional paper feeder is installed.

To change the paper size and media type of the multipurpose tray, select [MF Tray Set.] and change the Paper Size and Media Type. The available paper sizes and media types are shown in the table below.

Before selecting [MP Tray], select the multipurpose settings and change the Paper Size and Media Type. The available paper sizes and media types are shown in the table below.

[Auto]: Paper the same size as the original is automatically selected.

[Cassette 1] - [Cassette 3] : Select from cassettes 1 to 3. (Cassettes 2-3 are displayed when the optional paper feeder is installed.)

[MP Tray]: Select MP Tray.

[MF Tray Set.]: If you select [MP Tray], select [MF Tray Set.] and set the Paper Size and Media Type.

Paper Size

Standard Size

Value	Description
A4, A5-R, A5, A6, B5, B6, Letter, Legal, Statement, Executive, Oficio II, Folio, 216 × 340 mm, 16K, ISO B5, Envelope #10, Envelope #9, Envelope #6, Envelope Monarch, Envelope DL, Envelope C5, Hagaki (Cardstock), Oufukuhagaki (Return postcard), Yougata 4, Yougata 2, Nagagata 3, Nagagata 4, Younaga 3, Custom *1	Select from Standard Size and custom sizes.

[Size Entry]

Value	Description
Metric X: 70 to 216 mm (in 1 mm increments) Y: 148 to 356 mm (in 1 mm increments)	Enter the size not included in Standard Size. The input units can be changed in System Menu. ➔ Measurement (page 439) If [Size Entry] is selected, use [▲], [▼], or [Numeric keys] to set the size of "X" (width) and "Y" (length).
Inch X: 2.76 to 8.50" (in 0.01" increments) Y: 5.83 to 14.02" (in 0.01" increments)	

Media TypeMedia Type

Value	Description
Plain (60 to 105 g/m ²), Transparency, Labels, Recycled, Preprinted ^{*2} , Bond, Cardstock, Color, Prepunched ^{*2} , Letterhead ^{*2} , Envelope, Thick (106 to 220 g/m ²), High Quality, Custom 1 to 8 ^{*2}	Select the media type. Displayed after setting [Standard Size] and [Size Entry].

*1: For instructions on how to specify the custom paper size, refer to the following:

➔ [\[Orig./Paper Set.\] \(page 432\)](#)

*2: For instructions on how to specify the custom paper types 1 to 8, refer to the following:

➔ [\[Orig./Paper Set.\] \(page 432\)](#)

To print on preprinted or prepunched paper or on letterhead, refer to the following:

➔ [SpacialPaper Act. \(page 436\)](#)



NOTE

- You can conveniently select in advance the size and type of paper that will be used often and set them as default.
 - ➔ [\[Orig./Paper Set.\] \(page 432\)](#)
- If paper of the specified paper size is not loaded in the paper source cassette or multipurpose tray, the confirmation screen appears. When the setting is , if the detected size of paper is not loaded, a paper confirmation screen appears. Load the required paper in the multipurpose tray and select the [OK] key. Copying begins.

Mixed Size Orig.



Scan the documents of different sizes that are set in the document processor all at once. This function cannot be used if platen is used.

Copying

Value	Description
[Off]	—
[Same Width]	Scans and copies multiple sheets of the same width using the document processor.
[Different Width]	Scans and copies multiple sheets of different width using the document processor.

Sending/Storing

Value	Description
[Off]	—
[Same Width]	Scans and sends/stores multiple sheets of the same width using the document processor.
[Different Width]	Scans and sends/stores multiple sheets of different width using the document processor.

Supported Combinations of Originals

[Same Width]

When the original widths are the same, the combinations of originals that can be placed are as follows.

- A4 and Folio (Legal and Letter)

Example: Folio and A4

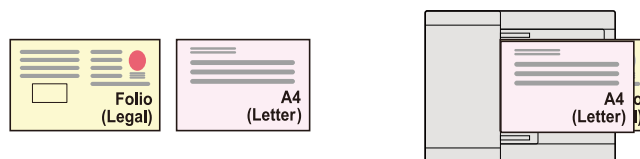

[Different Width]

The supported combinations of originals are as follows.

- Letter, A4, Folio, Legal

Example: A4, Legal

 **IMPORTANT**

When placing originals of different width, arrange the originals so that their left sides and top sides are aligned, and place the originals in alignment with the far width guide. If the originals are not aligned in this way, they may not be scanned correctly, and skewing or original jams may result.

Copy Size

Originals are detected individually for size and copied to the same size paper as originals.

 **NOTE**

This function is available regardless of whether originals have the same width or not.

Orig.Orientation



Select the orientation of the original document top edge to scan correct direction.

To use any of the following functions, the document's original orientation must be set.

- 2-Sided
- Border Erase, Border Erase/Full Scan
- Combine
- 2-Sided (2-Sided originals)

Select the orientation of the original from [Top Edge on Top], [Top Edge on Left] or [Auto].

[Top Edge on Top]

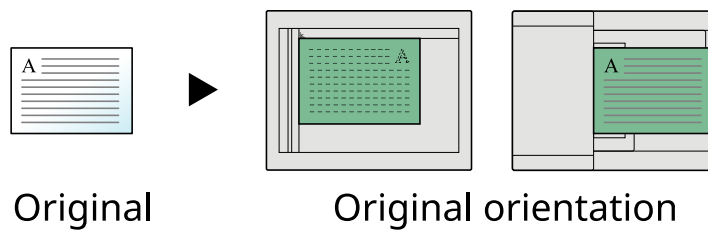

[Top Edge on Left]

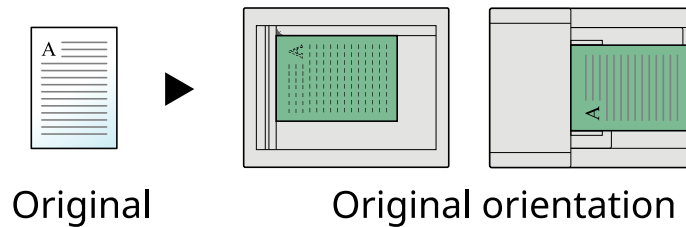

NOTE

The default setting for Original Orientation can be changed.

➔ [\[Function Default\] \(page 445\)](#)

Collate



Scans multiple originals and delivers complete sets of copies as required according to page number.
(Values [Off]/[On])

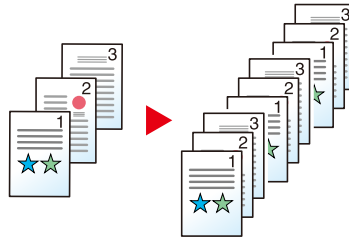

ID Card Copy



Use this when you want to copy a driver's license or an insurance card. When you scan the front and back of the card, both sides will be combined and copied onto a single sheet.

(Values [Off]/[On])

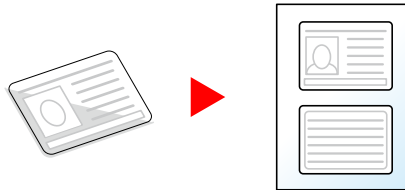

Density



Make the overall density darker or lighter.

Select [-4] to [4] (lighter to darker) to set the darkness.



Original Image



Select original image type for best results.

Original Image Quality (Copy)

[Text+Photo]

Highlighter

Value	Description
[Off], [On(Normal)], [On(High)]	Select [On] to reproduce the color of the text and markings made with highlighter pen. If the colors are not bright enough, select [On(High)].



NOTE

If gray text is not printed completely using [Text+Photo], selecting [Text] may improve the result.

[Photo]

Best for photos taken with a camera.

[Text]

Highlighter

Value	Description
[Off], [On(Normal)], [On(High)]	Select [On] to reproduce the color of the text and markings made with highlighter pen. If the colors are not bright enough, select [On(High)].

[Graphic/Map]

Highlighter

Value	Description
[Off], [On(Normal)], [On(High)]	Select [On] to reproduce the color of the text and markings made with highlighter pen. If the colors are not bright enough, select [On(High)].

Original Image (When sending/printing/saving)

[Text+Photo]

Best for mixed text and photo documents.

Highlighter

Value	Description
[Off], [On(Normal)], [On(High)]	Select [On] to reproduce the color of the text and markings made with highlighter pen. If the colors are not bright enough, select [On(High)].

[Photo]

Best for photos taken with a camera.

[Text]

Highlighter

Value	Description
[Off], [On(Normal)], [On(High)]	Select [On] to reproduce the color of the text and markings made with highlighter pen. If the colors are not bright enough, select [On(High)].

EcoPrint



EcoPrint saves toner when printing. Use this function for test prints or any other occasion when high quality print is not required.

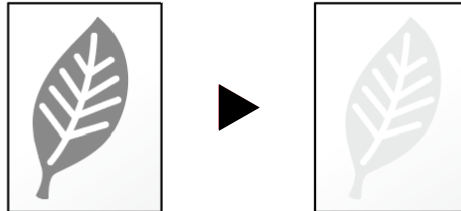

Value: [Off], [On]

Color Selection



Select the color setting.

Sending/Storing

Item	Description
[Auto (Color/Gray)]	Automatically recognizes whether the document is color or black and white, and scan color documents in Full Color and black and white documents in Grayscale.
[Auto (Color/B & W)]	Automatically recognizes whether the document is color or black and white, and scan color documents in Full Color and black and white documents in Black and White.
[Full Color]	Scans the document in full color.
[Grayscale]	Scans the document in grayscale. Produces a smooth, detailed image.
[Black & White]	Scans the document in black and white.

Sharpness



Adjusts the sharpness of image outlines.

When copying penciled originals with rough or broken lines, clear copies can be taken by adjusting sharpness toward "Sharpen". When copying images made up of patterned dots such as magazine photos, in which moire ^{*1} patterns appear, edge softening and weakening of the moire effect can be obtained by setting the sharpness toward "Blur".

Less Sharp



Original



More Sharp

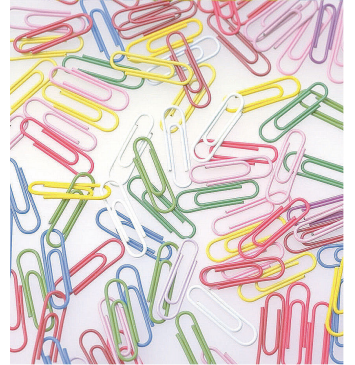

Value	Description
[1] to [3(Vivid)]	Emphasizes the image outline.
[-1] to [-3(Grayish)]	Blurs the image outline. Can weaken a Moire ^{*1} effect.

^{*1} Patterns that are created by irregular distribution of halftone dots.

Backgrnd Density



Removes dark background from originals, such as newspapers.

If the background color is obtrusive, select [Auto]. If selecting does not remove the background color, select [Manual] and adjust the density of the background color.

Item	Description
[Off]	Does not adjust the ground color.
[Auto]	Automatically adjusts the background density based on the original.
[Manual]	Select [1 (Lighter)] to [5 (Darker)] to adjust the background density manually.

Saturation



Adjust the color saturation of the image.

Grayish



Results in paler color.

Original



Vivid



Results in more vivid color.

NOTE

This feature is used when full color or auto color are selected in [Color Selection]. Saturation is disabled if Auto Color detects black and white originals.

Item	Description
[-1] to [-3] (lighter)	Results in paler color.
[1] to [3] (darker)	Results in more vivid color.

Prevent Bleed-t



Hides background colors and image bleed-through when scanning thin original.

(Values [Off]/[On])

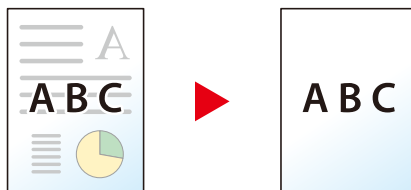

Contrast



You can adjust the contrast between light and dark areas of the image.

Lower



Original



Higher



Item	Description
1 to [4]	Increases the sharpness of colors.
[-1] to [-4]	Creates smoother colors.

Erase Colors



Erases colors in the source document.

[Off]/[On]

Value	Description
[Yellow], [Red], [Cyan], [Magenta], [Green], [Blue], [Black]	Select the colors to erase. You can select up to 6 colors. Choose the color and select [Select] > [Detail] to adjust the range for erasing.

Value	Description
[1] to [5]	The larger the number, the wider the range of colors you want to erase. For example, if you specify [Yellow] and select [5] from the color range, greens and reds close to yellow will be erased.

NOTE

If you select only [Black], you cannot set the color range.

Zoom



Adjust the zoom to reduce or enlarge the image.

Zoom (When copying)

The following zoom options are available.

[Auto]

Adjusts the image to match the paper size.

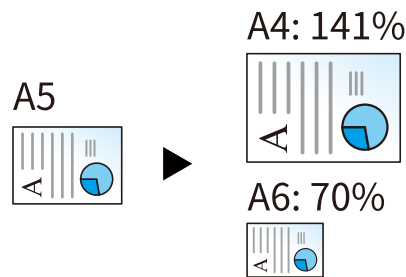

Standard Zoom

Select from main Standard Zoom and perform Zoom.

[400%]	-
[200%]	—
[141%]	A5→A4
[115%]	B5→A4
[100%]	—
[86%]	A4→B5
[70%]	A4→A5
[50%]	—
[25%]	-

Others

Reduce/enlarge using a magnification other than Standard Zoom. *1

[129%]	STMT LTR→ LTR
[90%]	FOL→ A4
[78%]	LGL→ LTR
[64%]	LTR→ STMT

*1: LTR = Letter, LGL = Legal, STMT = Statement, FOL = Folio

Zoom Entry

Manually reduces or enlarges the original image in 1% increments between 25% and 400%. [▲], [▼], or the numeric keys can be used to set the value.

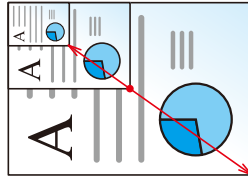

Zoom (When printing/sending/storing)

Item	Description
[100%]	Reproduces the original size.
[Auto]	Reduces or enlarges original to sending/storing size.

 **NOTE**

To reduce or enlarge the image, select the paper size, sending size, or storing size.

➔ [Paper Selection \(page 287\)](#)

➔ [Sending SizeSending Size \(page 325\)](#)

➔ [Storing Size \(page 342\)](#)

Combine

Copy

Combines 2 or 4 original sheets into 1 printed page.

You can select the page layout and the type of boundary lines around the pages.

The following types of the boundary lines are available.

**None****Solid Line****Dotted Line****Positioning Mark****[Off]****[2 in 1]**

If you select [Detail], you can perform the following settings.

If you select the [OK] key, it will be copied with the default settings. For the default settings, refer to the following:

➔ [\[Function Default\] \(page 445\)](#)

2 in 1 Layout

Value	Description
[L to R][T to B] [R to L][T to B]	Select the page layout of scanned originals and select the [OK] key.

Value	Description
[None], [Solid Line], [Dotted Line], [Positioning Mark]	Set the boundary line type and select the [OK] key.

Orig.Orientation

Value	Description
[Top Edge on Top], [Top Edge on Left]	Select the orientation of the original document top edge to scan correct direction. Select the orientation of the original from [Top Edge on Top] or [Top Edge on Left] and select the [OK] key.

[4 in 1]

If you select [Detail], you can perform the following settings.

If you select the [OK] key, it will be copied with the default settings. For the default settings, refer to the following:

➔ [\[Function Default\] \(page 445\)](#)

4 in 1 Layout

Value	Description
[Right then Down], [Down then Right], [Left then Down], [Down then Left]	Select the page layout of scanned originals and select the [OK] key.

Value	Description
[None], [Solid Line], [Dotted Line], [Positioning Mark]	Set the boundary line type and select the [OK] key.

[Orig.Orientation]

Value	Description
[Top Edge on Top], [Top Edge on Left]	Select the orientation of the original document top edge to scan correct direction. Select the orientation of the original from [Top Edge on Top] or [Top Edge on Left] and select the [OK] key.

Layout image (2 in 1)

[L to R][T to B]

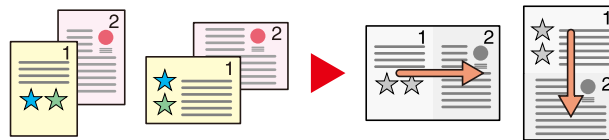

[R to L][T to B]

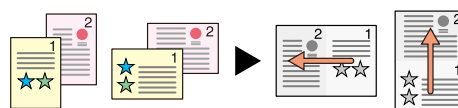

Layout image (4 in 1)

[Right then Down]

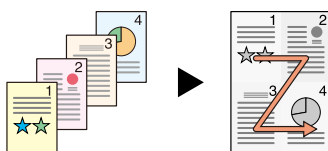

[Left then Down]

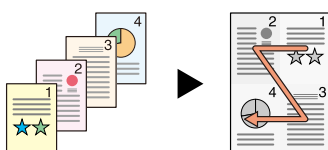

[Down then Right]

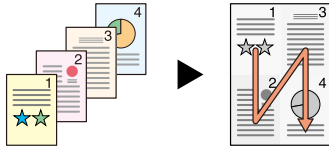

[Down then Left]

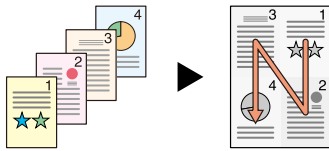

 **NOTE**

- The paper sizes supported in Combine mode are A4, A5-R, B5, Folio, 216 × 340 mm, Letter, Legal, Statement, Oficio II, and 16K.
 - When placing the original on the platen, be sure to copy the originals in page order.
-

Border Erase



Erases the black borders that form around the image. The border can be erased as follows:

Standard

Erase the black frame created in the original. Erasing width is fixed.

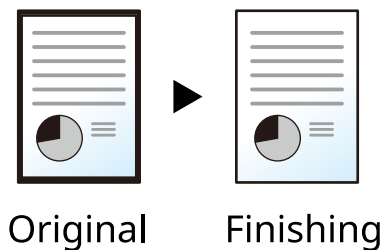

Full Scan

Scan originals without white margins. No border erase.

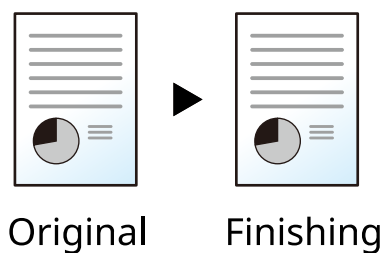

Sheet

Erase the black frame created in the original. Erasing width can be adjusted.

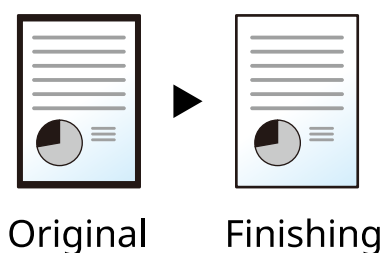

[Border]

Value	Description
Centimeters: 0 mm - 50 mm (in 1 mm increments), Inches: 0.00 - 2.00" (in 0.01" increments)	Set the border erase width.* ¹ Set the value by using [+] or [-]. Entry can also be made using the numeric keys. You can set the border erase width for the back side of double-sided originals by setting the border erase width of [Border] and selecting the [OK] key.

Value	Description
[Same as Front], [Do Not Erase]	For 2-sided originals, select [Same as Front] or [Do Not Erase].

Book

Erases black borders around the edges and in the middle of the original such as a thick book. You can specify the widths individually to erase the borders around the edges and in the center of the book.

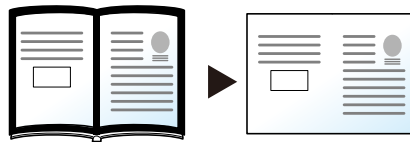

Original

Finishing

[Border]

Value	Description
Centimeters: 0 mm - 50 mm (in 1 mm increments), Inches: 0.00 - 2.00" (in 0.01" increments)	Set the border erase width of Border and select the [OK] key.* ¹ Set the value by using [+] or [-]. Entry can also be made using the numeric keys.

[Gutter]

Value	Description
Centimeters: 0 mm - 50 mm (in 1 mm increments), Inches: 0.00 - 2.00" (in 0.01" increments)	Set the border erase width of Gutter and select the [OK] key.* ¹ Set the value by using [+] or [-]. Entry can also be made using the numeric keys. You can set the border erase width for the back side of double-sided originals by setting the border erase width of [Border] and [Gutter] and selecting the [OK] key.

Value	Description
[Same as Front], [Do Not Erase]	For 2-sided originals, select [Same as Front] or [Do Not Erase].

Individual

You can specify border erase widths individually for all edges.



[Top]/[Bottom]/[Left]/[Right]

Value	Description
Centimeters: 0 mm - 50 mm (in 1 mm increments), Inches: 0.00 - 2.00" (in 0.01" increments)	<p>Set the border erase widths separately for top, bottom, left, and right, and select the [OK] key.*¹</p> <p>Set the value by using [+] or [-].</p> <p>Entry can also be made using the numeric keys.</p> <p>You can set the border erase width for the back side of double-sided originals by setting the border erase width of [Right] and selecting the [OK] key.</p>

Value	Description
[Same as Front], [Do Not Erase]	For 2-sided originals, select [Same as Front] or [Do Not Erase]

NOTE

- [Full Scan] is not displayed when copying.
- The default setting for border erase width and back side can be changed. For details, refer to the following:
 - ➔ [Border Erase def \(page 448\)](#)

*1: The input units can be changed in System Menu. For details, refer to the following.

➔ [Measurement \(page 439\)](#)

DuplexDuplex



Produces two-sided copies. You can also create single-sided copies from two-sided originals.

The following modes are available.

1-sided>>2-sided

Produces two-sided copies from one-sided originals. In case of an odd number of originals, the back side of the last copy will be blank.

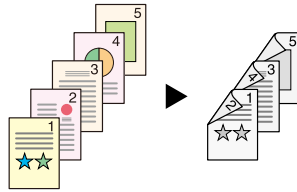

The following binding options are available.

- 1 Binding Left/Right: Images on the second sides are not rotated.
- 2 Binding Top: Images on the second sides are rotated 180 degrees. Copies can be bound on the top edge, facing the same orientation when turning the pages.

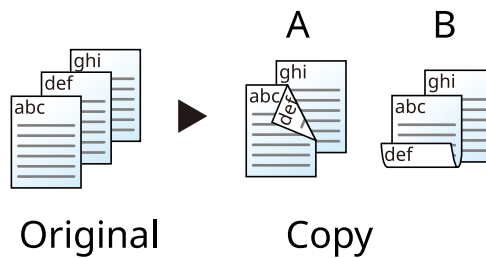

2-sided>>1-sided

Copies each side of a two-sided original onto two individual sheets. Place originals in the document processor.

The following binding options are available.

- Binding Left/Right: Images on the second sides are not rotated.
- Binding Top: Images on the second sides are rotated 180 degrees.



2-sided>>2-sided

Produces two-sided copies from two-sided originals. Place originals in the document processor.

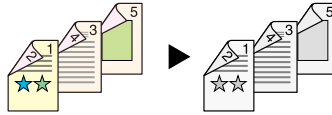

NOTE

The paper sizes supported in Duplex mode: A4, A5-R, A6, B5, Letter, Legal, Statement, Executive, Oficio II, Folio, 16K, ISO B5

Duplex (When copying)

Prints 1-sided originals to 2-sided, or 2-sided originals to 1-sided. Select the binding orientation for original and finished documents.

[1-sided>>1-sided]

Disables the function.

[1-sided>>2-sided]

If you select the [OK] key, it will be copied with the default settings. For the default settings, refer to the following:

➔ [\[Function Default\] \(page 445\)](#)

If you select [Detail], you can perform the [Finish. Binding] and [Orig.Orientation] settings.

Finish. Binding

Value	Description
[Left/Right], [Top]	Select the binding orientation and select the [OK] key.

Orig.Orientation

Value	Description
[Top Edge on Top], [Top Edge on Left]	Select the orientation of the original document top edge to scan correct direction. Select the orientation of the original from [Top Edge on Top,] or [Top Edge on Left] and select the [OK] key.

[2-sided>>1-sided]

If you select the [OK] key, it will be copied with the default settings. For the default settings, refer to the following:

➔ [\[Function Default\] \(page 445\)](#)

If you select [Detail], you can perform the [Orig. Binding] and [Orig.Orientation] settings.

Orig. Binding

Fixed value	Description
[Left/Right], [Top]	Select the binding direction of originals and select the [OK] key.

Orig.Orientation

Value	Description
[Top Edge on Top], [Top Edge on Left]	Select the orientation of the original document top edge to scan correct direction. Select the orientation of the original from [Top Edge on Top] or [Top Edge on Left] and select the [OK] key.

[2-sided]>>2-sided]

If you select the [OK] key, it will be copied with the default settings. For the default settings, refer to the following:

→ [\[Function Default\] \(page 445\)](#)

If you select [Detail], you can perform the , [Finish. Binding][Orig. Binding], and [Orig.Orientation] settings.

Orig. Binding

Value	Description
[Left/Right], [Top]	Select the binding direction of originals and select the [OK] key.

Finish. Binding

Value	Description
[Left/Right], [Top]	Select the binding orientation and select the [OK] key.

Orig.Orientation

Value	Description
[Top Edge on Top], [Top Edge on Left]	Select the orientation of the original document top edge to scan correct direction. Select the orientation of the original from [Top Edge on Top] or [Top Edge on Left] and select the [OK] key.

When placing the original on the platen, consecutively replace each original and press the [Start] key.

After scanning all originals, select [End Scan]. Copying begins.

Duplex (USB drive)

Prints the document on both sides.

Select binding orientation for duplex mode.

[1-sided]

Disables the function.

[Duplex]

If you select the [OK] key, it will be copied with the default settings. For the default settings, refer to the following:

➔ [\[Function Default\] \(page 445\)](#)

If you select [Detail], you can perform the [Finish. Binding] and settings.

If you select [Description], you can perform the [Finished Binding Direction] settings.

Value	Description
[Left/Right]	Prints on both sides so that the correct orientation is achieved when binding the paper on the left or right.
[Top]	Prints on both sides so that the correct orientation is achieved when binding the paper at the top.

Continuous Scan



Scans a large number of originals in separate batches and then produces as one job.

Scanning of originals will continue until [Finish Scan] is selected.

Value: [Off], [OnOn]

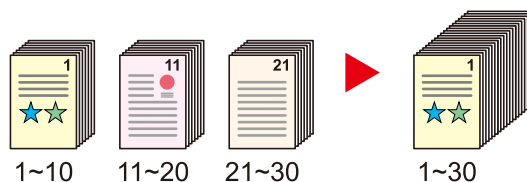

JobFinish Notice



Sends E-mail notice when a job is complete.

It can also be set up to send a notice when a job is interrupted.

Users can be notified of the completion of a job while working at a remote desk, saving the time spent waiting beside the machine to finish.

NOTE

- PC should be configured in advance so that E-mail can be used. For details, refer to the following:
 → [What is Command Center RX \(page 112\)](#)
- E-mail can be sent to a single destination.
- It is possible to download the scan data to PC from the URL provided in the Job Finish Notice E-mail in the event of "Send to Folder (SMB/FTP)". This is a useful function in case if it is not possible to send/receive a large amount of scan data due to the restriction of the mail attachment file size.

Item	Description
[Off]	—
[JobFinished Only]	Sends E-mail notice only when a job is complete.
[Fin.+Interrupted]	Notifies you when a job ends and when a job is interrupted.

If you select [JobFinished Only] or [Fin.+Interrupted], you can select [Address Book] or [Address Entry] as the destination specification method.

Item	Description
------	-------------

File Name Entry



Name a document.

Additional information such as job number and date and time can also be set. You can check a job history or job status using the file name, date and time, or job number specified here.

Enter the file name (up to 32 characters) and select the [OK] key.

To add a date and time, select [Date] and then select the [OK] key. To add a job number, select [Job No.] and then select the [OK] key. To add both, select [Job No. + Date] or [Date + Job No.] and then select the [OK] key.

Priority Override



Suspends the current job and gives a new job top priority.
The suspended job resumes after the other job is finished.

NOTE

- This function is not available if current job was an override.
 - Priority printing may not be possible depending on the status of the job being printed and memory usage.
-

FoldingDetection



When scanning a document from the document processor, scanning is automatically stopped when a document with a folded corner is detected.

Value	Description
[Off]	It does not detect.
[On]	If a bent corner is detected, a message is displayed to stop reading the original.

Skip Blank Page



When there are blank pages in a scanned document, this function skips the blank pages and prints only pages that are not blank.

Blank pages can be set as pages that include ruled lines and a small number of characters.

The machine detects blank pages, saving unnecessary printing without the need to check for blank pages in the document.

Selecting [On] > [Detail] displays the screen.

Select from [Blank+Ruled Line], [Blank Pages Only] or [Blank+Some Text].



NOTE

The originals with punched holes or originals printed on a colored substrate may not be recognized as blank pages.

Duplex

Duplex2-Sided (2-Sided originals)



Select the type and orientation of the binding based on the original.

[1-sided]

There is no setting for the binding or the original orientation.

[2-sided]

If you select the [OK] key, it will be copied with the default settings. For the default settings, refer to the following:

→ [\[Function Default\] \(page 445\)](#)

If you select [Detail], you can perform the [Orig. Binding] and [Orig.Orientation] settings.

[Orig. Binding]

Value	Description
[Left/Right], [Top]	Set the binding direction of originals and select the [OK] key.

[Orig.Orientation]

Value	Description
[Top Edge on Top], [Top Edge on Left]	Specify the orientation of the original document top edge and select the [OK] key to scan the correct direction.

Sample image

[Duplex] > [Left/Right]



[Duplex] > [Top]



Sending Size



Select size of image to be sent.

Select from [Same as Orig. Size] or the list below.

[Same as Orig. Size]

Automatically sends the same size as the original.

Value	Description
A4, A5, A6, B5, B6, Letter, Legal, Statement, Executive, Oficio II, Folio, 216 × 340 mm, 16K, ISO B5, Envelope #10, Envelope #9, Envelope #6, Envelope Monarch, Envelope DL, Envelope C5, postcard, return postcard, Yogai No. 4, Yogai No. 2, Nagata No. 3, Nagata No. 4, Yocho No. 3	Choose from standard sizes and special standard sizes.

Regarding the relationship among Original Size, Sending Size, and Zoom

Original Size, Sending Size, and Zoom are related to each other. For details, see the table below.

- Original Size and sending size are the same

Original Size

Specify as necessary.

➔ [Original Size \(page 286\)](#)

Sending Size

Select [Same as Orig. Size].

Zoom

Select [100%] (or [Auto]).

➔ [Zoom \(page 305\)](#)

- Original Size and sending size are different

Original Size

Specify as necessary.

➔ [Original Size \(page 286\)](#)

Sending Size

Select the desired size.

Zoom

Select [Auto].

➔ [Zoom \(page 305\)](#)

 **NOTE**

When you specify the Sending Size that is different from Original Size and select [100%] as Zoom, you can send the image as the actual size (no zoom).

File Format



Specify the image file format. Image quality level can also be adjusted.

Select the file format from [PDF], [TIFF], [XPS], [JPEG], [OpenXPS], and [High Comp.PDF].

When the color mode in scanning has been selected for Grayscale or Full Color, set the image quality.

If you selected [PDF] or [High Comp.PDF], you can specify encryption or PDF/A settings.

Select the [OK] key to save or send in PDF format. Image quality and PDF/A settings will be set to default values.

NOTE

The image quality, PDF/A, etc. of each file are as the settings made in the function default settings. For the default settings, refer to the following:

→ [\[Function Default\] \(page 445\)](#)

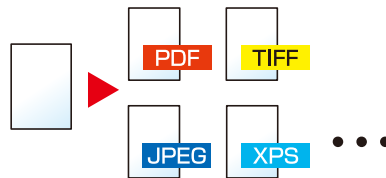

[PDF]

[Image Quality]

Value	Description
1 Low(High Comp) to 5 High(Low Comp)	Selecting [Detail] displays the [Image Quality] screen. Select the image quality, and select the [OK] key.

[Encryption]

Value	Description
[Off], [On]	Set the encrypted PDF and select the [OK] key. If you select [On], refer to the following. → PDF Encryption Functions (page 329)

[PDF/A]

Value	Description
[Off], [PDF/A-1a], [PDF/A-1b], [PDF/A-2a], [PDF/A-2b], [PDF/A-2u]	Select the PDF/A-1 format and select the [OK] key.

[DigitalSignature]

Value	Description
[Off][On]	Selecting [On] enables you to set digital signature to file. ➔ PDF Electronic Signature (page 332)

[TIFF]

[Image Quality]

Value	Description
to	Selecting [Detail] displays the [Image Quality] screen. Select the image quality, and select the [OK] key.

[XPS]

[Image Quality]

Value	Description
to	Selecting [Detail] displays the [Image Quality] screen. Select the image quality, and select the [OK] key.

[OpenXPS]

[Image Quality]

Value	Description
to	Selecting [Detail] displays the [Image Quality] screen. Select the image quality, and select the [OK] key.

[JPEG]

[Image Quality]

Value	Description
1 to 5	Selecting [Detail] displays the [Image Quality] screen. Select the image quality, and select the [OK] key.

[High Comp.PDF]

[Image Quality]

Value	Description
[Comp. Priority], [Normal], [Quality Priority]	Selecting [Detail] displays the [Image Quality] screen. Select the image quality, and select the [OK] key.

[Encryption]

Value	Description
[Off], [On]	Set the encrypted PDF and select the [OK] key. If you select [On], refer to the following. ➔ PDF Encryption Functions (page 329)

[PDF/A]

Value	Description
[Off], [PDF/A-1a], [PDF/A-1b], [PDF/A-2a], [PDF/A-2b], [PDF/A-2u]	Select the PDF/A-1 format and select the key.

[DigitalSignature]

Value	Description
[Off][On]	Selecting [On] enables you to set digital signature to file. ➔ PDF Electronic Signature (page 332)

PDF Encryption Functions

If you have selected PDF or High Comp. PDF for file format, you can restrict the access level for displaying, printing, and editing PDF's by assigning a secure password.

Select [PDF] or [High Comp.PDF], [Encryption] > select [On].

Items that can be set vary depending on the setting selected in Compatibility.

If Acrobat3.0&Later is selected

[Open Document]

Value	Description
[Off], [Permit]	Enter the password to open the PDF file. Select On, and enter a password (up to 256 characters). Enter the password again for confirmation.

[Edit/Print Doc.]

Value	Description
[Off], [Permit]	Enter the password to edit the PDF file. Select On, and enter a password (up to 256 characters). Enter the password again for confirmation. When you have entered the password to edit document, you can specifically limit the operation.

Printing Allowed

Value	Description
[Off], [Permit]	Disables the printing of PDF file.

Changes Allowed

Value	Description
[Not Allowed]	Disables the change to the PDF file.
[Commenting]	Can only add commenting.
[Page Layout]	Can change the page layout except extracting the pages of the PDF file.
[Any Changes]	Can conduct all operations except extracting the pages of the PDF file.

Copying Contents

Value	Description
[Disable], [Enable]	Restricts the copying of text and objects on the PDF file.

If Acrobat 5.0 & Later is selected**[Open Document]**

Value	Description
[Off], [OnOn]	Enter the password to open the PDF file. Select On, and enter a password (up to 256 characters). Enter the password again for confirmation.

[Edit/Print Doc.]

Value	Description
[Off], [OnOn]	Enter the password to edit the PDF file. Select On, and enter a password (up to 256 characters). Enter the password again for confirmation. When you have entered the password to edit document, you can specifically limit the operation.

Printing Allowed

Value	Description
[Not Allowed]	Disables the printing of PDF file.
[Allowed(LowRes.)]	Can print the PDF file only in low resolution.
[Permit]	Can print the PDF file in original resolution.

Changes Allowed

Value	Description
[Not Allowed]	Disables the change to the PDF file.
[Ins./Del./Rotat.]	Can only insert, delete, and rotate the pages of the PDF file.
[Commenting]	Can only add commenting.
[Any Changes]	Can conduct all operations except extracting the pages of the PDF file.

Copying Contents

Value	Description
[Disable], [Enable]	Restricts the copying of text and objects on the PDF file.

PDF Electronic Signature

If [PDF] or [High Comp.PDF] is selected as a file format, electronic signature can be added to the PDF to be sent. Electronic signature can certify a sender of document and prevent falsification. To use this function, it is required to register a signing certificate from Command Center RX or KYOCERA Net Viewer and enable digital signature to files from the system menu. In this manual, a procedure to register a signing certificate from Command Center RX is described as an example.

NOTE

- This function can be configured when [Off], [PDF/A-2a], [PDF/A-2b], [PDF/A-2u] is selected in PDF/A.
- To register a signing certificate from KYOCERA Net Viewer, refer to the following.

➔ **KYOCERA Net Viewer User Guide**

1 Access to Command Center RX.

➔ [Accessing Command Center RX \(page 113\)](#)

2 Register the signature certificate used in the digital signature addition setting

- 1 From the [Functions] menu, click [Common/Job Defaults].
- 2 Click [File Default Settings] in [Signing Certificate] > [Settings] to create or import the device certificate.

➔ **Command Center RX User Guide**

- 3 Click [Restart/Reset] > [Restart entire device] to restart the device.

3 Configure the digital signature settings.

- 1 [System Menu/Counter] key > [▲] [▼] keys > [Send] > [OK] key > [▲] [▼] keys > [DigitalSignature] > [OK] key

NOTE

If the user authentication screen appears, log in with a user who has the privilege to configure this setting. If you do not know your login user name or password, please contact your administrator.

- 2 Configure the digital signature addition settings.

Configurable items are as follows:

[DigitalSignature]

Select whether to add a digital signature.

[Off]

Does not add a digital signature.

[Specify Each Job]

Whether to add a digital signature is selected each time of sending.

[On]

Always adds a digital signature when sending.

[Format]

Select an algorithm used for encryption of digital signature.

Value: [SHA-1], [SHA-256], [SHA-384], [SHA-512]



NOTE

This function is displayed when Digital Signature is set to [Specify Each Job] or [On].

[Password Confirm]

Select whether to confirm password when setting digital signature.

Value: [Off], [On]

[Password]

Set a password required for setting digital signature. Enter a new security password 6 to 16 alphanumeric characters and symbols.



NOTE

[Password] is displayed when you select [Specify Each Job] from Digital Signature and [On] is selected in [Password Confirm] displayed after restart.

3 Select [OK].

4 [Send] key > [Function Menu] key > [▲][▼] key > [File Format] > [OK] key

5 Configure the settings

1 Select [PDF] or [High Comp.PDF] as a file format.

2 From "Digital Signature", select [On] > [OK] key in order.



NOTE

This function is displayed when [Specify Each Job] is set in Step 3-2. When [On] is selected for , the password entry screen will be displayed. Enter a password set in the system menu.

➔ [Password Policy Settings \(page 486\)](#)

6 Press the [Start] key.

File Separation



Creates multiple files for each scanned original data page.

(Value: [Off]/[Each Page])

When you select [Each Page], file separation is set.

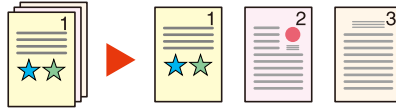

NOTE

A three-digit serial number such as "abc_001.pdf, abc_002.pdf..." is attached to the end of the file name.

Scan Resolution



Select fineness of scanning resolution.

(Value: [600x600dpi]/[400x400dpi U.Fin]/[300x300dpi]/[200x400dpi S.Fin]/[200x200dpi Fine]/[200x100dpi Normal])

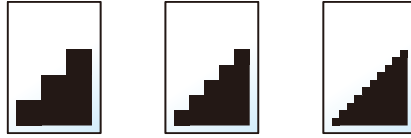

 **NOTE**

The larger the number, the better the image resolution. However, better resolution also means larger file sizes and longer send times.

Clarify Text (Noise Removal)



When scanning and sending a document in black and white, it eliminates background noise and improves the legibility of the text.

Value: [Off], [On]

Subject/Body

Send

Adds subject and body when sending a document.

Select "Subject Entry"/"Body Entry" to enter the Email subject/body.

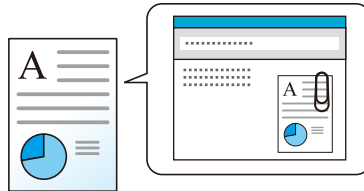

 **NOTE**

The subject can include up to 60 characters, and the body can include up to 500 characters.

FTP Encrypted TX

Send

Encrypts images when sending via FTP.

Encryption secures the document transmission.

Value: [Off], [On]

NOTE

In Command Center RX, click [Security Settings] → [Network Security] in order. Be sure that "TLS" of Secure Protocol Settings is [On] and one or more effective encryption are selected in Client side settings.

➔ [Command Center RX User Guide](#)

EmailEncryptedTX



Sends encrypted E-mail using the electronic certificate.

Encryption secures the document transmission.

(Values [Off]/[On])

NOTE

To use this function, configure the certificate, protocol and email function in the Command Center RX.

➔ [Configuring S/MIME in Command Center RX \(page 340\)](#)

DigitalSignature

Send

Add a digital signature to the email, using the electronic certificate.

By adding a digital signature to an email, you can confirm the identity of the destination and detect tampering during transmission.

(Values [Off]/[On])

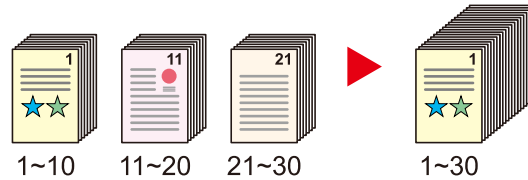

NOTE

To use this function, configure the certificate, protocol and email function in Command Center RX.

➔ [Configuring S/MIME in Command Center RX \(page 340\)](#)

Configuring S/MIME in Command Center RX

When using the Email Encrypted TX and Digital Signature to Email functions, make the following settings in Command Center RX.

1 Access to Command Center RX.

➔ [Accessing Command Center RX \(page 113\)](#)

2 Register the device certificate which is used for S/MIME.

- 1 From the [Security Settings] menu, click [Certificates].
- 2 Click "Device Certificate" of [Settings] (1 to 5) to create or import the device certificate.
➔ **Command Center RX User Guide**
- 3 Click [Restart/Reset] > [Restart entire device] to restart the device.

3 Configure the protocol settings

- 1 From the [Network Settings] menu, click [Protocols].
- 2 Set "Send Protocol" and [SMTP (E-mail TX)] of [S/MIME] to [On].
- 3 Click [Submit].

4 Configure the E-mail function.

- 1 From the [Functions] menu, click [E-mail].
- 2 Configure the settings in "S/MIME Settings" as necessary.
➔ **Command Center RX User Guide**
- 3 Click [Submit].

5 Link the E-mail address with S/MIME certificates

- 1 From the [Address Book] menu, click [Machine Address Book].
- 2 Click the contact's [Number] or [Name] you want to edit.
- 3 Click "S/MIME Certificate" in [Settings].
- 4 Click [Import] on the required certificate to register it, and then click [Submit].
- 5 Click [OK].

Storing Size



Select size of image to be stored.

Value	Description
Same as original size, A4, A5, A6, B5, B6, Letter, Legal, Statement, Executive, Oficio II, Folio, 216 × 340 mm, 16K, ISO B5, Envelope #10, Envelope #9, Envelope #6, Envelope Monarch, Envelope DL, Envelope C5, Hagaki (Cardstock), Oufukuhagaki (Return postcard), Yougata 4, Yougata 2, Nagagata 3, Nagagata 4, Younaga 3	If you want to use a size different from the original size, select from the standard sizes.

Regarding the relationship among Original Size, Storing Size, and Zoom

Original Size, Storing Size, and Zoom are related. For details, see the table below.

- Original Size and the size you wish to store as are the same

Original Size

Specify as necessary.

➔ [Original Size \(page 286\)](#)

Storing Size

Select [Same as Orig. Size].

Zoom

Select [100%] (or [Auto]).

➔ [Zoom \(page 305\)](#)

- Original Size and the size you wish to store as are different

Original Size

Specify as necessary.

➔ [Original Size \(page 286\)](#)

Storing Size

Select the desired size.

Zoom

Select [Auto].

➔ [Zoom \(page 305\)](#)



NOTE

When you select Storing Size that is different from Original Size, and select the Zoom [100%], you can store the image as the actual size (No Zoom).

Encrypted PDF



Enter the password you set to print the PDF data.

Enter the password and select [OK].



For details on entering the password, refer to the following:

➔ [Character Entry \(page 761\)](#)

JPEG/TIFF Print



Select the image size when printing JPEG or TIFF files.

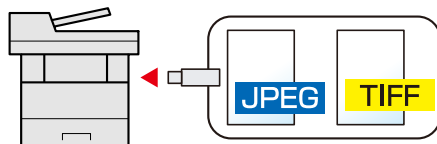

Item	Description
[Paper Size]	Fits the image size to the selected paper size.
[Image Resolution]	Prints at resolution of the actual image.
[Print Resolution]	Fits the image size to the print resolution.

XPS FitTo Page



Reduces or enlarges the image size to fit to the selected paper size when printing XPS file.

(Values: [Off], [On])

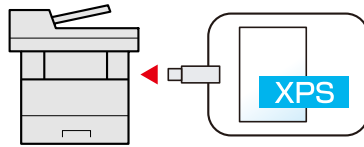

7 Status/Job Cancel

Checking Job Status

Check the status of jobs being processed or waiting to be printed.

Available Status Screens

The processing and waiting statuses of jobs are displayed as a list on the touch panel in four different screens - Printing Jobs, Sending Jobs, Storing Jobs, and Scheduled Jobs.

The following job statuses are available.

Status Screens	Job status to be displayed
Print Job Status	<ul style="list-style-type: none"> • Copy • Printer • Fax reception • Email reception • Printing data from USB Drive • Application • Printing Report/List
Send Job Status	<ul style="list-style-type: none"> • Email • Sending Job Folder • Fax transmission • Sending Job - Fax Server • Sending Job Application • Multiple destination
Store Job Status	<ul style="list-style-type: none"> • Scan • Fax • Printer
Scheduled Job	Sending Job FAX using Delayed transmission

Displaying Status Screens

1 Display the screen

[Status/Job Cancel] key > [Delete][▲][▼] keys > [Print Job Status] > [Send Job Status], [Store Job Status]
or > [Scheduled Job] > [OK] key

2 Select the job you want to check.

- 1 Select the job to confirm, and select [Menu].
- 2 [▲][▼] keys > [Detail] > [OK] key
- 3 The status of the jobs is displayed.
 - ➔ [Print Job Status \(page 349\)](#)
 - ➔ [Send Job Status \(page 351\)](#)
 - ➔ [Store Job Status \(page 353\)](#)
 - ➔ [Scheduled Job Status \(page 354\)](#)



NOTE

- If you select a fax job on the [Send Job Status] screen, [PriorityOverride] will be displayed. Select [PriorityOverride] and select the [OK] key to pause the current job and give priority to the selected job.
 - In [Scheduled Job], [Start Now] is displayed. Select [Start Now] and select the [OK] key to submit the selected job immediately.
-

3 Check the information.

Select the [▶] key to display the next page. Select the [◀] key to return to the previous page. Select the [OK] key.

- ➔ [Print Job Status \(page 349\)](#)
- ➔ [Send Job Status \(page 351\)](#)
- ➔ [Store Job Status \(page 353\)](#)
- ➔ [Scheduled Job Status \(page 354\)](#)

Details of the Status Screens

NOTE

- You can show the job statuses of all users, or only the statuses of your own jobs.
→ [\[Disp. Status/Log\] \(page 455\)](#)
- This setting can also be changed from Command Center RX. For details, refer to the following:
→ [Command Center RX User Guide](#)



Print Job Status

Item	Description
Status	Status of job [Processing]: The status before starting to print [Pause]: Pausing print job or error [Canceling]: Canceling the job [-----]: The job has finished.
Accepted Time	Accepted time of job
Job Name	When the job name cannot be displayed because the job name is too long, selecting Detail will display the entire job name. Selecting the [OK] key will return to the original screen.
Job Type	[Copy]: Print copy [FAX] Fax reception and print [Box]: Printing from a document box [Printer]: Printer job [Report]: Printing report/list [E-mail]: Email reception and print [USB]: Printing data from USB drive
User Name	User Name for the executed job [-----] is displayed when user login administration is disabled.
Page and Copy	<ul style="list-style-type: none"> Number of printed pages Number of printed pages/Total number of printed pages
Original Pages	Original pages

Item	Description
Sender Info.	<p>Displays information about the sender.</p> <p>For fax reception</p> <p>If a sender name is set when receiving a fax, the sender name will be displayed. If only the sender number is set, only the number will be displayed.</p> <p>If there is no sender information, or if fax has not been received, [-----]---- is displayed.</p> <p>For email</p> <p>The email address appears.</p> <p>Otherwise, [---- -] is displayed.</p> <hr/> <p> NOTE</p> <p>When the sender information is too long to be displayed, selecting [Detail] will display the entire sender information. Selecting the [OK] key will return to the original screen.</p> <hr/>

Send Job Status

Item	Description
Status	Job status [Processing]: The status before starting to send, such as during scanning originals [Pause]: Pausing the job [Canceling]: Canceling the job
Accepted Time	Accepted time of job
Job Name	When the job name cannot be displayed because the job name is too long, selecting [Detail] will display the entire job name. Selecting the [OK] key will return to the original screen.
Job Type	[FAX]: Fax transmission [E-mail]: Email transmission [Folder] Sending job folder [Application]: Application transmission [Multi]: Multiple destination [FAX Server]: Fax server transmission
User Name	User Name for the executed job [-----] is displayed when user login administration is disabled.
Original Pages	Original pages
Color/B & W	Color mode [Color/B & W] [Full Color] [Black & White] [Grayscale] [Mixed] [Auto (Color/Gray)] [Auto (Color/B & W)]

Item	Description
Destination	<p>Destination is displayed. When there is only one destination Destination (any of destination name, FAX number, email address, or server name)</p> <hr/> <p> NOTE</p> <p>When the sender information is too long to be displayed, selecting [Detail] will display the entire sender information. Selecting the [OK] key will return to the original screen.</p> <hr/> <p>When there are multiple destinations [Broadcast] is displayed. Selecting [List] will display all destinations. Selecting the [Exit] key will return to the original screen.</p> <hr/> <p> NOTE</p> <p>If the sender information is too long to be displayed, select the destination and select the [OK] key to return to the previous screen.</p> <hr/>

Store Job Status

Item	Description
Accepted Time	Accepted Time of job
Job Type	[Scan]: Save scan [FAX]: Save fax [Printer]: Save printer
Job Name	When the job name cannot be displayed because the job name is too long, selecting Detail will display the entire job name. Selecting the [OK] key will return to the original screen.
User Name	[-----] is displayed when user login administration is disabled.
Status	Status of job [Processing]: The status before starting to save, such as during scanning originals [Canceling]: Canceling the job
Original Pages	Original pages
Color/B & W	Color mode [Color/B & W] [Full Color] [Black & White] [Grayscale] [Mixed] [Auto (Color/Gray)] [Auto (Color/B & W)]
Sender Info.	<p>Displays information about the sender. For fax reception</p> <p>If a sender name is set when receiving a fax, the sender name will be displayed. If only the sender number is set, only the number will be displayed. If there is no sender information, or if fax has not been received, [-----]---- is displayed.</p> <hr/> <p> NOTE</p> <p>When the sender information is too long to be displayed, selecting [Detail] will display the entire sender information. Selecting the [OK] key will return to the original screen.</p> <hr/>

Scheduled Job Status

Item	Description
Status	Job status [Waiting]: Waiting sending
DestinationAccepted Time	Destination is displayed. ➔ Send Job Status (page 351)
User Name	User Name for the executed job [-----] is displayed when user login administration is disabled.
[Start Time]	Time to start the scheduled job
Original Pages	Original pages
Color/B & W	Color mode [Black & White]
Job Name	When the sender information is too long to be displayed, selecting [Detail] will display the entire sender information. Selecting the [OK] key will return to the original screen.
Job Type	[FAX] is displayed.

Checking Job History

 **NOTE**

- Job history is also available by Command Center RX or KYOCERA Net Viewer from the computer. For details, refer to the following:
 - ➔ **Command Center RX User Guide**
 - ➔ **KYOCERA Net Viewer User Guide**
- You can show the job log of all users, or only your own job log.
 - ➔ [\[Disp. Status/Log\] \(page 455\)](#)
- This setting can also be changed from Command Center RX. For details, refer to the following:
 - ➔ **Command Center RX User Guide**

Available Job History Screens

The job histories are displayed separately in three screens - Printing Jobs, Sending Jobs, and Storing Jobs. The following job histories are available.

Screen	Job histories to be displayed
Print job	<ul style="list-style-type: none"> • Copy • Printer • Fax reception • Email reception • Printing data from USB Drive • Application • Printing Report/List
SSend job	<ul style="list-style-type: none"> • Email • Sending Job Folder • Fax transmission • Sending Job - Fax Server • Sending Job Application • Multiple destination
Store job	<ul style="list-style-type: none"> • Scan • Fax • Printer
Fax job	➔ FAX Operation Guide

Displaying Job History Screen

1 Display the screen

- 1 [Status/Job Cancel] key > [**▲**] [**▼**] keys > [Print Job Log] > [Send Job Log], [Store Job Log] or [FAX Job Log] > [OK] key

→ **FAX Operation Guide**

2 Select the job you want to check.

- 1 Select the job to confirm, and select [Detail].

An icon showing the result of the job is displayed to the right of each job.

OK: The job finished normally.

 : Job error

 : Job cancelled



NOTE

You can show the job log of all users, or only your own job log.

→ [\[Disp. Status/Log\] \(page 455\)](#)

This setting can also be changed from Command Center RX.

→ **Command Center RX User Guide**

3 Checking Job History

- 1 Select the [**▶**] key to display the next page. Select the [**◀**] key to return to the previous page.

Print Job History

Results

Job results

[OK]: The Job is completed.

[Error]: Error has occurred.

[Cancel]: The job has been canceled.

Accepted time

Accepted time of job

End time

Job end time

Job Name

When the job name cannot be displayed because the job name is too long, selecting [Detail] will display the entire job name. Selecting the [OK] key will return to the original screen.

Job Type

[Copy]: Print copy

[FAX] Fax reception and print

- [Box]: Printer job
- [Printer]: Print copy
- [Report]: Printing report/list
- [E-mail]: Email reception and print
- [USB]: Data printing from external media

User Name

- User Name for the executed job
- [-----] is displayed when user login administration is disabled.

Pages and number of copies

- Number of printed pages
- Number of printed pages/Total number of printed pages

Original pages

- Original pages

Sender Information

- Displays information about the sender.

➔ [Send Job Status \(page 351\)](#)

Send Job Log

Results

- Job results
- [OK]: The Job is completed.
- [Error]: Error has occurred.
- [Cancel]: The job has been canceled.

Accepted time

- Accepted time of job

End time

- Job end time

Job Name

- When the job name cannot be displayed because the job name is too long, selecting [Detail] will display the entire job name. Selecting the [OK] key will return to the original screen.

Job Type

- [E-mail]: Email transmission
- [Folder]: PC (SMB/FTP) transmission
- [FAX]: Fax transmission
- [Application]: Application transmission
- [Multi]: Multi transmission
- [FAX Server]: Fax server transmission

User Name

- User Name for the executed job
- [-----] is displayed when user login administration is disabled.

Original pages

Original pages

Color/Black & White

Color mode

[Color/B & W]

[Full Color]

[Black & White]

[Grayscale]

[Mixed]

Destination

Destination is displayed.

➔ [Send Job Status \(page 351\)](#)



NOTE

If the login user name entry screen appears during operations, log in.

Store Job Log

Results

Job results

[OK]: The Job is completed.

[Error]: Error has occurred.

[Cancel]: The job has been canceled.

Accepted time

Accepted time of job

End time

Job end time

Job Name

When the job name cannot be displayed because the job name is too long, selecting [Detail] will display the entire job name. Selecting the [OK] key will return to the original screen.

Job Type

[FAX]: Save fax

[Scan]: Save scan

[Printer]: Save printer

User Name

User Name for the executed job

[----] is displayed when user login administration is disabled.

Original pages

Original pages

Color/Black & White

Color mode

[Color/B & W]

[Full Color]

[Black & White]

[Grayscale]

[Mixed]

Sender Information

Displays information about the sender.

➔ [Send Job Status \(page 351\)](#)

Sending the Log History

You can send the log history by E-mail. You can either send it manually as needed or have it sent automatically whenever a set number of jobs is reached.

Job Operation

Pause and Resumption of Jobs

Pause/resume all printing jobs in printing/waiting.

1 Display the screen

- 1 Select the [Status/Job Cancel] key.

2 Select [Pause].

Printing is paused.

When resuming the printing of jobs that have been paused, select [Resume].



NOTE

Selecting a function key such as the [Back] key or the [Copy] key while the job is paused will [Resume paused jobs. Are you sure?] is displayed. Select [Yes] and select the [OK] key to restart the job and display the following screen. If you select [No] and select the [OK] key, the job remains paused and the following screen appears.

Canceling of Jobs

A job in printing/waiting status can be canceled.

1 Display the screen

[Status/Job Cancel] key > [▲] [▼] keys > [Print Job Status] > [Send Job Status] > [Store Job Status] or > [Scheduled Job] > [OK] key

2 Cancel a job.

For a print job

- 1 Select the job to cancel, and select the [Menu] key.
- 2 [▲] [▼] keys > [Cancel Job] > [OK] key > [Yes][Yes]

 **NOTE**

If you select a fax-in job, [Cannot cancel FAX reception jobs.] is displayed, and the job cannot be canceled.

For send job status, save job status, or reserve job

- 1 Select the job to cancel, and select the [Cancel] key.

 **NOTE**

To cancel the job, select [Menu], [Cancel], and then the [OK] key.

- 2 Select [Yes].

Check the device information

Configure the devices/lines installed or connected to this machine or check their status.

1 Display the screen

- 1 Select the [Status/Job Cancel] key.
- 2 Select the item to check. Select the [OK] key to display the status of the selected device.

2 Check the information.

Select the item to check. Select the [OK] key to display the status of the selected device.

[Rmt. Op. Status]

You can check the situation of remote operation. To end remote operation, select [Disconnect].

[Scanner]

Statuses such as document scanning status and standby status are displayed.

[Printer]

Status such as waiting and printing are displayed.

[FAX]

Information such as sending/receiving or dialing is displayed.

Select [Line Off] cancel the fax being sent/received.



NOTE

Displays only for fax models.

➔ [FAX Operation Guide](#)

[Unit Condition]

You can check the remaining life of the drum unit and the cassette.

[USB]

The usage/total capacity/free space of the USB drive connected to this machine is displayed. Select [Remove] to safely remove the USB drive.

[USB Keyboard]

Displays the status of the USB keyboard.

[Network]

Displays the state of the network connection.

[Wi-Fi]

You can check the status of Wi-Fi connection, such as the connection status, IP address, and the network name (SSID address) of the machine.

[Wi-Fi Direct]

Displays the Wi-Fi direct connection status and the network name (SSID) of the machine.

[Security]

You can check the security information on the machine.

Checking the Remaining Amount of Toner and Paper, and the Condition of the Unit

On the message display, you can check the presence of toner and paper, as well as the remaining life of the unit.

1 Display the screen

- 1 Select the [Status/Job Cancel] key.

2 Check the information.

[▲] [▼] keys > [Toner Status] or [Paper Status] > [OK] key

The items you can check are described below.

[Toner Status]

The amount of toner remaining is shown in levels.

[Paper Status]

Displays the status of the paper source. Select the [▶] key to display the next paper source. Select the [◀] key to return to the previous page.

[Unit Condition]

Displays the time remaining on the Developer Unit, the Document Processor, and the Cassette.

Select the [▶] key to display the next page. Select the [◀] key to return to the previous page.

8 System Menu

Operation Method

Configure settings related to overall machine operation. System Menu is operated as follows:

1 Display the screen

Selecting the [System Menu/Counter] key will display the setting screen in the message display. Select the displayed setting.

→ [Using the Operation Panel \(page 57\)](#)

Refer to the following system items and configure the necessary settings.

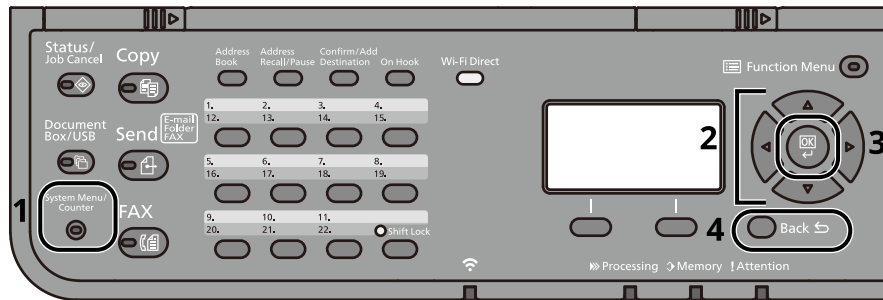

- 1 Displays the System Menu items.
- 2 Select the displayed item or change the value.
- 3 Confirm the selected settings.
- 4 Cancels the current settings and returns to the next level up.



NOTE

- When setting functions that require administrator privileges, you must log in with administrator privileges. If you do not know your login user name or password, please contact your administrator.
- If function default settings have been changed, the [Reset] key can be selected in each function screen to immediately change the settings.

System Menu Settings

This section explains the functions that can be configured in System Menu. To configure the settings, select the item in System Menu and select the setting item.

For details on each function, see the table below.

[Report]

Print reports to check the machine settings and status.

➔ [\[Report\] \(page 369\)](#)

[Counter]

Check the number of pages printed.

➔ [\[Counter\] \(page 374\)](#)

[System/Network]

Explains about this machine's system.

➔ [\[Network Setting\] \(page 375\)](#)

[User/Job Account]

Configures settings related to machine management.

➔ [\[User/Job Account\] \(page 422\)](#)

[Common Settings]

Configure each setting.

➔ [\[Common Settings\] \(page 425\)](#)

[Copy]

Configures settings for copying functions.

➔ [\[Copy\] \(page 466\)](#)

[Printer]

Change the printer's initial settings to suit your environment.

➔ [\[Printer\] \(page 467\)](#)

[Send]

Configures settings for sending functions.

➔ [\[Send\] \(page 470\)](#)

[FAX]

Configures settings for fax functions.

➔ [\[FAX\] \(page 473\)](#)

[Document Box]

Configure settings for F Code Box, Job Box and Polling Box.

➔ [\[Document Box\] \(page 474\)](#)

[Application]

Configure the application settings.

➔ [\[Application\] \(page 475\)](#)

[Edit Destination]

Configure settings for address book.

➔ [\[Edit Destination\] \(page 476\)](#)

[Adjust/Maint.]

Adjust printing quality and conduct machine maintenance.

➔ [\[Adjust/Maint.\] \(page 478\)](#)

[Report]

Print reports to check the machine settings, status, and history. Settings for printing reports can also be configured.

[Report Print]

[System Menu/Counter] key > [▲][▼] keys > [Report] > [OK] key > [▲][▼] keys > [Report Print] > [OK] key

Item	Description
[Menu Map]	Prints the Menu Map. The machine's settings can be checked.
[Config. List]	Print the system settings as the list.
[Status Page]	<p>Prints the status page. You can check information such as the current settings, available memory, and installed optional equipment.</p> <div data-bbox="703 766 1361 1061" data-label="Image"> </div>
[Service Status]	Prints the service status. More detailed information is available than on the Status Page. Service personnel usually print the service status pages for maintenance purpose.
[Account. Report]	If job accounting is enabled, the total pages counted of all relevant accounts can be printed as an accounting report.
[Font List]	<p>Prints the font list. You can check the fonts installed in this machine with a sample.</p> <div data-bbox="791 1422 1264 1709" data-label="Image"> </div>
[DataSanitization]	Prints the data sanitization report.

[Admin Rpt Set.]

[System Menu/Counter] key > [▲] [▼] keys > [Report] > [OK] key > [▲] [▼] keys > [Admin Rpt Set.] > [OK] key

This item is displayed for fax-compatible machines.

Configure settings for Outgoing Fax report and Incoming Fax report.

➔ **FAX Operation Guide**

[Result Rpt Set.]

[System Menu/Counter] key > [▲] [▼] keys > [Report] > [OK] key > [▲] [▼] keys > [Result Rpt Set.] > [OK] key

Configure settings for notices for sending and receiving.

[Send Result]

Automatically print a report of transmission result when a transmission is complete.

Item	Description
[E-mail/Folder]	Automatically print a report of transmission result when Email or SMB/FTP transmission is complete. Value: [Off], [On], [Error Only]
[FAX]	➔ FAX Operation Guide
[Attached NW FAX]	➔ FAX Operation Guide
[CancelBeforeSend]	Print a send result report if the job is canceled before being sent. Value: [Off], [On] (Not displayed when both [E-mail/Folder] and [FAX] are [Off].)
[Dest. Info.]	Select the Recipient Format for the send result report. Value: [Dest. or Name] (Not displayed when both [E-mail/Folder] and [FAX] are [Off].)

[FAX RX Result]

Displays only for fax models.

➔ **FAX Operation Guide**

[JobFinish Notice]

This item is displayed for fax-compatible machines.

For details, refer to the following:

➔ **Fax Operation Guide**

[Jobs Log]

[System Menu/Counter] key > [▲] [▼] keys > [Report] > [OK] key > [▲] [▼] keys > [Jobs Log] > [OK] key

Item	Description
[Auto Sending]	<p>This function automatically sends the log history to the specified destinations whenever a set number of jobs has been logged.</p> <p>Value: [Off], [On]</p> <hr/> <p> NOTE</p> <p>If [On] is selected, specify the number of job histories to be sent automatically. The setting range is 1 to 16.</p> <hr/>
[Send History]	<p>You can also send the log history to the specified destinations manually. You must have already specified the destination in [Destination].</p>
[Destination]	<p>Set the destination to which log histories are sent. Only E-mail address can be set.</p> <p>Value: [Confirmation], [Register]</p> <p>If you select [Confirmation], you can confirm the destination specified in [Destination].</p> <p>If you select [Register], you can specify the destination as [Address Book] or [Address Entry].</p>
[Subject]	<p>Set the subject automatically entered when sending log histories by E-mail.</p> <p>Value: Up to 60 characters</p>
[Personal Info.]	<p>Select whether to include personal information in the job log.</p> <p>Value: ,</p>

History Management

It is possible to perform Log Management for the following logs on this machine.

Jobs Log

Log subject

Copy/Fax/Scan/Send/Print job completion

Checking job status/Changing of jobs/Canceling of jobs

Log information

Event occurrence date and time

Event type

Information on users logged in (or users who attempted to log in)



If the user authentication screen appears, log in with a user who has the privilege to configure this setting. If you do not know your login user name or password, please contact your administrator.

[Counter]

[System Menu/Counter] key > [▲] [▼] keys > [Counter] > [OK] key

Item	Description
[Printed Pages]	You can check the number of pages printed. Value: [by Function], [by Paper Size], [by Duplex], [by Combine]
[Scanned Pages]	You can check the total number of pages loaded for copy, fax, etc.

[System/Network]

[Network Setting]

Configure the machine system.

[System Menu/Counter] key > [▲] [▼] keys > [System/Network] > [OK] key > [▲] [▼] keys > [Network Setting] > [OK] key

Configures network settings.

[Host Name]

[System Menu/Counter] key > [▲] [▼] keys > [System/Network] > [OK] key > [▲] [▼] keys > [Network Setting] > [OK] key > [Host Name] > [OK] key

Item	Description
[Host Name]	Check the host name of the machine. Host name can be changed from Command Center RX. ➔ Changing Device Information (page 115)

[Wi-Fi Easy Setup]

[System Menu/Counter] key > [▲] [▼] keys > [System/Network] > [OK] key > [▲] [▼] keys > [Network Setting] > [OK] key > [▲] [▼] keys > [Wi-Fi Easy Setup] > [OK] key





Set up Wi-Fi using your computer or mobile device.

Select [Yes] and follow the instructions on the screen.

[Wi-Fi Direct Set]

[System Menu/Counter] key > [▲] [▼] keys > [System/Network] > [OK] key > [▲] [▼] keys > [Network Setting] > [OK] key > [Wi-Fi Direct Set] > [OK] key > [Wi-Fi Direct] > [OK] key

Set Wi-Fi Direct.

Item	Description
[Wi-Fi Direct]	Select whether to use Wi-Fi Direct. Value: [Off], [On]
[Device Name]	Specify the device name. <hr/>  NOTE <ul style="list-style-type: none"> • Up to 32 characters can be entered. • This function is displayed when [Wi-Fi Direct] is set to [On]. <hr/>
[IP Address]	Check the IP address of the machine. → [TCP/IP Settings] (page 385) <hr/>  NOTE <p>This function is displayed when [Wi-Fi Direct] is set to [On].</p> <hr/>
[Auto Disconnect]	Automatically disconnect devices connected through Wi-Fi Direct. Value: [Off], [On] <hr/>  NOTE <ul style="list-style-type: none"> • If you select [On], set the waiting time for automatic disconnection. • This function is displayed when [Wi-Fi Direct] is set to [On]. <hr/>
[Persistent Group]	Set whether Wi-Fi Direct connection as Persistent Group (information for the connection is kept even if the power is turned off). Value: [Off], [On] <hr/>  NOTE <p>This function is displayed when [Wi-Fi Direct] is set to [On].</p> <hr/>

Item	Description
[Password]	<p>Select whether the Wi-Fi Direct password is automatically generated or created manually.</p> <p>When [Auto] is selected, the Persistent Group setting changes to [On].</p> <p>When [Auto] is selected, the Persistent Group setting changes to [On].</p> <p>Value: [Auto], [Manual]</p> <hr/> <p> NOTE</p> <p>If [Manual] is selected, set a password (8 or more characters).</p> <hr/>
[Frequency Band]	<p>Set the frequency band to be used.</p> <p>Value: [2.4GHz], [5GHz]</p>

[Wi-Fi Settings]

[System Menu/Counter] key > [▲] [▼] keys > [System/Network] > [OK] key > [▲] [▼] keys > [Network Setting] > [OK] key > [Wi-Fi Settings] > [OK] key > [Wi-Fi]

Set Wi-Fi Direct.

[Wi-Fi]

Item	Description
[Wi-Fi]	<p>Select whether to use Wi-Fi. Value: [Off], [On]</p> <hr/> <p> NOTE</p> <p>If you select [On], restart your network for the setting to take effect.</p> <hr/>

[Setup]

Item	Description
[ConnectionStatus]	You can check the status of wireless LAN.

[Quick Setup]

If you want to connect to an access point that supports automatic wireless network configuration, you can configure the connection using a simple setup.

 **NOTE**

When connecting to an access point configured for WEP, select [WEP Key Index] and select WEP Key Index.

Item	Description
[Available Net.]	<p>Select connectable access points, select the [OK] key, and enter the WEP key or the pre-shared key to connect.</p> <hr/> <p> NOTE</p> <ul style="list-style-type: none"> • Select [Reload] and the computer list will be reloaded. • If the access point security setting is WEP, select [Menu] and set WEP Key Index in the range of 0 to 3. <hr/>

Item	Description
[Push Button]	<p>If the access point supports the push button method, wireless settings can be configured using the push button. This setting executes push button, and the connection is started by pressing the push button on the access point.</p> <hr/> <p> NOTE</p> <p>The push button method supports only the WPS.</p> <hr/>
[PIN (Device)]	<p>Starts connection using the machine's PIN code. Enter the PIN code into the access point. The PIN code of the machine is automatically generated.</p>

[Custom Setup]

The detailed settings for wireless LAN can be changed.

Item	Description
[NetwkName(SSID)]	<p>Set the SSID (Service Set Identifier) of the wireless LAN to which the machine connects.</p> <hr/> <p> NOTE</p> <p>Up to 32 characters can be entered.</p> <hr/>
[Netwk Authentic.]	<p>Select network authentication type.</p> <p>Value: [Open], [WPA2/WPA-PSK], [WPA2-PSK], [WPA2/WPA-EAP], [WPA2-EAP], [WPA3SAE/WPA2PSK], [WPA3-SAE], [WPA3/WPA2-EAP], [WPA3-EAP]</p>

Item	Description
[Encryption]	<p>Select encryption method. The setting values vary depending on the Network Authentication setting.</p> <p>Open Value: [Disabled], [WEP]</p> <hr/> <p> NOTE</p> <p>If you selected [WEP], set the WEP key (up to 26 characters) and WEP Key Index (0 to 3).</p> <hr/> <p>WPA2/WPA-PSK Value: [AES], [Auto], [Preshared Key] (up to 64 characters)</p> <p>WPA2-PSK Value: [Preshared Key] (up to 64 characters)</p> <p>WPA2/WPA-EAP Value: [AES], [Auto]</p> <p>WPA2-EAP Value: -----</p> <p>WPA3-SAE/WPA2-PSK Value: [Preshared Key]</p> <p>WPA3-SAE Value: [Preshared Key]</p> <p>WPA3/WPA2-EAP Value: -----</p> <p>WPA3-EAP Value: -----</p>

[Auto CH Control]

Item	Description
[Auto CH Control]	<p>Select [On] to use the best channel by checking the radio wave conditions around you.</p> <p>Value: [Off], [On]</p>





[TCP/IP Settings]

Item	Description
[TCP/IP]	<p>Select whether to use TCP/IP Protocol.</p> <p>Value: [Off], [On]</p>

[IPv4 Setting]

Set up TCP/IP (IPv4) to connect to the network.

Displayed when TCP/IP is set to [On].

Item	Description
[DHCP]	Select whether to use the DHCP (IPv4) server. Value: [Off], [On]
[Auto-IP]	Select whether to use Auto-IP. Value: [Off], [On]
[IP Address]	Set the IP address. Value: ###.###.###.### <hr/>  NOTE When DHCP is set to [On], the value cannot be entered.
[Subnet Mask]	Set the IP subnet mask. Value: ###.###.###.### <hr/>  NOTE When DHCP is set to [On], the value cannot be entered.
[Default Gateway]	Set the Default gateway. Value: ###.###.###.### <hr/>  NOTE When DHCP is set to [On], the value cannot be entered.
[DNS Server]	Set the IP address of DNS (Domain Name System) server. Value: [Auto (DHCP)], [Manual] <hr/>  NOTE When [Manual] is selected, enter the DNS server IP address into [DNS Server] and [DNS Server].
[DNS over TLS]	Set whether to connect to a SNS server during communication protected by TLS. Value: [Off], [On], [Auto]



 **IMPORTANT**



- When setting the Auto-IP, enter "0.0.0.0" in IP Address.
- After changing the setting, restart the network or turn the machine OFF and then ON.

[IPv6 Setting]

Set up TCP/IP (IPv6) to connect to the network.

Displayed when TCP/IP is set to [On].

Item	Description
[IPv6 Setting]	<p>Select whether to use IPv6. Value: [Off], [On]</p> <hr/> <p> NOTE</p> <p>Selecting [On] displays IP Address in [Link Local] after restarting the network.</p> <hr/>
[Manual Settings]	<p>Manually specify the IP address, prefix length, and gateway address of TCP/IP (IPv6). Value [IP Address] 128-bits address is expressed in eight groups consisting of four-digit hexadecimal digits. The groups are separated by colon (:). [Prefix Length] 0 to 128 [Default Gateway] 128-bits address is expressed in eight groups consisting of four-digit hexadecimal digits. The groups are separated by colon (:).</p> <hr/> <p> NOTE</p> <ul style="list-style-type: none"> • This function is displayed when [IPv6 Setting] is set to [Off]. • To enter [Default Gateway], set [RA(Stateless)] to [Off]. <hr/>
[RA(Stateless)]	<p>Select whether to use RA (Stateless). Value: [Off], [On]</p> <hr/> <p> NOTE</p> <ul style="list-style-type: none"> • This function is displayed when [IPv6 Setting] is set to [On]. • Selecting [On] displays [IP Address 1] - [IP Address 5] to after restarting the network. <hr/>

Item	Description
[DHCPv6 Settings]	<p>Select whether to use the DHCP (IPv6) server. Value: [Off], [On]</p> <hr/> <p> NOTE</p> <ul style="list-style-type: none"> • This function is displayed when [IPv6 Setting] is set to [On]. • Selecting [On] displays IP address in [IP Address] after restarting the network. <hr/>
[DNS Server]	<p>Set the IP address of DNS (Domain Name System) server. Value: [Auto (DHCP)], [Manual]</p> <hr/> <p> NOTE</p> <p>When [Manual] is selected, enter the DNS server IP address into [DNS Server] and [DNS Server].</p> <hr/>
[DNS over TLS]	<p>Set whether to connect to a DNS server during communication protected by TLS. Value: [Off], [On], [Auto]</p>

 **IMPORTANT**

After changing the setting, restart the network or turn the machine OFF and then ON.

[Restart Network]

Item	Description
[Restart Network]	Restarts the network.

[Wired Netwk. Set]

[System Menu/Counter] key > [▲] [▼] keys > [System/Network] > [OK] key > [▲] [▼] keys > [Network Setting] > [OK] key > [Wired Netwk. Set] > [OK] key

Configure wired network settings.

[TCP/IP Settings]

[TCP/IP]



Select whether to use TCP/IP Protocol.

Value: [Off], [On]

[IPv4 Setting]

Set up TCP/IP (IPv4) to connect to the network.

This setting is available when [TCP/IP] is [On].

Item	Description
[DHCP]	Select whether to use the DHCP (IPv4) server. Value: [Off], [On]
[Auto-IP]	Select whether to use Auto-IP. Value: [Off], [On]
[IP Address]	Set the IP address. Value: ###.###.###.### <hr/>  NOTE When DHCP is set to [On], the value cannot be entered. <hr/>
[Subnet Mask]	Set the IP subnet mask. Value: ###.###.###.### <hr/>  NOTE When DHCP is set to [On], the value cannot be entered. <hr/>
[Default Gateway]	Set the IP gateway address. Value: ###.###.###.### <hr/>  NOTE When DHCP is set to [On], the value cannot be entered. <hr/>

Item	Description
[DNS Server]	Set the IP address of DNS (Domain Name System) server. Value: [Auto (DHCP)], [Manual] <hr/>  NOTE When [Manual] is selected, enter the DNS server IP address into [Primary Server] and [Secondary Server]. <hr/>
[DNS over TLS]	Set whether to connect to a DNS server during communication protected by TLS. Value: [Off], [On], [Auto]

 **IMPORTANT**



- When setting the Auto-IP, enter "0.0.0.0" in IP Address.
- After changing the setting, restart the network or turn the machine OFF and then ON.

[IPv6 Setting]

Set up TCP/IP (IPv6) to connect to the network.

This setting is available when [TCP/IP] is [On].

Item	Description
[IPv6 SettingIPv6 Setting]	Select whether to use IPv6. Value: [Off], [On] <hr/>  NOTE Selecting [On] displays IP address in [Link LocalLink Local] after restarting the network. <hr/>

Item	Description
[Manual Settings]	<p>Manually specify the IP address, prefix length, and gateway address of TCP/IP (IPv6).</p> <p>Value</p> <p>[IP AddressIP Address]</p> <p>128-bits address is expressed in eight groups consisting of four-digit hexadecimal digits. The groups are separated by colon (:).</p> <p>[Prefix Length]</p> <p>0 to 128</p> <p>[Default Gateway]</p> <p>128-bits address is expressed in eight groups consisting of four-digit hexadecimal digits. The groups are separated by colon (:).</p> <hr/> <p> NOTE</p> <ul style="list-style-type: none"> • This function is displayed when [IPv6 Setting] is set to [On]. • To enter [Default GatewayDefault Gateway], set [RA(Stateless)] to [Off].
[RA (Stateless)]	<p>Select whether to use RA (Stateless).</p> <p>Value: [Off], [On]</p> <hr/> <p> NOTE</p> <ul style="list-style-type: none"> • This function is displayed when [IPv6 Setting] is set to [On]. • Selecting [On] displays [IP Address 1] - [IP Address 5] to after restarting the network.
[DHCPv6 Settings]	<p>Select whether to use the DHCP (IPv6) server.</p> <p>Value: [Off], [On]</p> <hr/> <p> NOTE</p> <ul style="list-style-type: none"> • This function is displayed when [IPv6] is set to [On]. • Selecting [On] displays IP address in [IP Address] after restarting the network.

Item	Description
[DNS Server]	<p>Set the IP address of DNS (Domain Name System) server. Value: [Auto (DHCP)], [Manual]</p> <hr/> <p> NOTE</p> <p>When [Manual] is selected, enter the DNS server IP address into [Primary Server] and [Secondary Server].</p> <hr/>
[DNS over TLS]	<p>Set whether to connect to a DNS server during communication protected by TLS. Value: [Off] , [On] , [Auto]</p>

 **IMPORTANT**

After changing the setting, restart the network or turn the machine OFF and then ON.

[LAN Interface]

Item	Description
[LAN Interface]	Specify the settings for the LAN interface to be used. Value: [Auto], [10Base-Half], [10Base-Full], [100Base-Half], [100Base-Full], [1000Base-T]

 **IMPORTANT**

After changing the setting, restart the network or turn the machine OFF and then ON.

[Bonjour]

[System Menu/Counter] key > [▲] [▼] keys > [System] > [OK] key > [▲] [▼] keys > [Network] > [OK] key > [▲] [▼] keys > [Bonjour] > [OK] key

Item	Description
[Bonjour]	Select whether to use [Bonjour]. Value: [Off], [On]

[IP Filter (IPv4)]

[System Menu/Counter] key > [▲] [▼] keys > [System] > [OK] key > [▲] [▼] keys > [Network] > [OK] key > [▲] [▼] keys > [IP Filter (IPv4)] > [OK] key

Item	Description
[IP Filter (IPv4)]	<p>Configure the IP Filter Setting. IP filter is a function used to restrict the access to the machine by setting the IP address and protocol.</p> <p>The IP address or network address of permitted hosts is set from Command Center RX. Not setting the IP Filter will allow access from all hosts.</p> <p>Value: [OffOff], [OnOn]</p> <p>➔ Command Center RX User Guide</p>

IP Filter (IPv6)

[System Menu/Counter] key > [▲] [▼] keys > [System] > [OK] key > [▲] [▼] keys > [Network] > [OK] key > [▲] [▼] keys > [IP Filter (IPv6)] > [OK] key

Item	Description
[IP Filter (IPv4)]	<p>Configure the IP Filter Setting. IP filter is a function used to restrict the access to the machine by setting the IP address and protocol.</p> <p>The IP address or network address of permitted hosts is set from Command Center RX. Not setting the IP Filter will allow access from all hosts.</p> <p>Value: [OffOff], [OnOn]</p> <p>➔ Command Center RX User Guide</p>

[IPSec]

[System Menu/Counter] key > [▲] [▼] keys > [System] > [OK] key > [▲] [▼] keys > [Network] > [OK] key > [▲] [▼] keys > [IPSec] > [OK] key

Item	Description
[IPSec]	Set whether or not to use the IPSec. Value: [OffOff], [OnOn]

[ProtocolSettings]

[System Menu/Counter] key > [▲] [▼] keys > [System/Network] > [OK] key > [▲] [▼] keys > [Network Setting] > [OK] key > [▲] [▼] keys > [ProtocolSettings] > [OK] key

Configures protocol settings.

[SNMPv3]

Item	Description
[SNMPv3]	Set whether to communicate using SNMPv3. The setting will be changed after restarting the device or network. Value: [Off], [On]

[FTP(Server)]

Item	Description
[FTP(Server)]	Set whether to send documents using FTP. The setting will be changed after restarting the device or network. Value: [Off], [On]

[FTP(Client)]

Item	Description
[FTP(Server)]	Set whether to send documents using FTP. If the setting is [On], you can specify the port number used by FTP. Typically, use 21. Value: [Off], [On] (Port Number: 1 to 65535)

[SMB(Server)]

Item	Description
[SMB(Server)]	Set whether to send documents using SMB. If the setting is [On], you can specify the port number used by SMB. Typically, use 445. Value: [Off], [On] (Port Number: 1 to 65535)
[SMBv1]	Set whether to send documents using SMBv1. Value: [Off], [On]
	 NOTE This setting is available when [SMB(Server)] is [On].

[SMB(Client)]

Item	Description
[SMB(Client)]	Select whether to send documents using SMB. Value: [Off], [On]

[SNMP]

Item	Description
[SNMP]	Select whether to communicate using SNMP. The setting will be changed after restarting the device or network. Value: [Off], [On]

[SMTP]

Item	Description
[SMTP]	Select whether to send Email using SMTP. The setting will be changed after restarting the device or network. Value: [Off], [On]

[POP3]

Item	Description
[POP3]	Select whether to send Email using POP3. Value: [Off], [On]

[RAW Port]

Item	Description
[RAW Port]	Set whether to receive documents using the Raw Port. The setting will be changed after restarting the device or network. Value: [Off], [On]

[LPD]

Item	Description
[LPD]	Set whether to send documents using LPD. The setting will be changed after restarting the device or network. Value: [Off], [On]

[IPP]

Item	Description
[IPP]	<p>Set whether to send documents using IPP. To use this, select [On] for this setting, and select [Off] for in the . Then select [Secure Only (IPPS)] in the security settings from Command Center RX. The factory default port number is 631.</p> <p>Value: [Off], [On], 1 to 32767 (Port Number)</p>

[IPP over TLS]

Item	Settings
[IPP over TLS]	<p>Sets whether to receive documents using TLS-protected IPP. To use this, select [On] in these settings, and select [On] for in the . The factory default port number is 443.</p> <p>In [Security] set [TLS Setting] to [On].</p> <p>The setting will be changed after restarting the device or network.</p> <p>Value: [Off], [On], 1 to 32767 (Port Number)</p> <hr/> <p> NOTE</p> <p>If the setting is [On], a TLS certificate is required. The factory certificate is the certificate owned by the machine.</p> <hr/>

[HTTP]

Item	Description
[HTTP]	<p>Select whether to communicate using HTTP.</p> <p>The setting will be changed after restarting the device or network.</p> <p>Value: [Off], [On]</p>

[HTTPS]



Item	Description
[HTTPS]	<p>Set whether to communicate using HTTPS.</p> <p>In [Security] set [TLS Setting] to [On].</p> <p>The setting will be changed after restarting the device or network.</p> <p>Value: [Off], [On]</p>

[LDAP]

Select whether to use LDAP.

Item	Description
[LDAP]	Set whether to communicate using HTTPS. The setting will be changed after restarting the device or network. Value: [Off], [On]

[ThinPrint]

Item	Settings
[ThinPrint]	Set whether to use ThinPrint. To use this, select [On] in these settings. The factory default port number is 4000. The setting will be changed after restarting the device or network. Value: [Off], [On] <hr/>  NOTE This feature does not appear if the optional ThinPrint Option is not running.
[ThinPrintOverTLS]	To use ThinPrint over TLS, select [On] for this setting, and for in the , select [On]. Value: [Off], [On] <hr/>  NOTE If the setting is [On], a TLS certificate is required. The factory certificate is the certificate owned by the machine.
[Available Net.]	Set whether to enable this function for each network of Wi-Fi Direct, Wi-Fi and wired by selecting [Detail]. Value: [Disabled], [Enabled]

[WSD-SCAN]

Item	Description
[WSD-SCAN]	Select whether to use WSD-SCAN. The setting will be changed after restarting the device or network. Value: [Off], [On]

[WSD-PRINT]

Item	Description
[WSD-PRINT]	Select whether to communicate using WSD-PRINT. The setting will be changed after restarting the device or network. Value: [Off], [On]

[Enhanced WSD]

Item	Description
[Enhanced WSD]	Set whether to use our proprietary web services. The setting will be changed after restarting the device or network. Value: [Off], [On]

[EnhancedWSD(TLS)]

Item	Description
[EnhancedWSD(TLS)]	Set whether to use our proprietary Web service on TLS. In [Security] set [TLS Setting] to [On]. The setting will be changed after restarting the device or network. Value: [Off], [On]

[eSCL]

Item	Description
[eSCL]	Sets whether to receive scanned documents using eSCL. The setting will be changed after restarting the device or network. Value: [Off], [On]

[eSCL over TLS]

Item	Description
[eSCL over TLS]	Sets whether to receive scanned documents using TLS-protected eSCL. The setting will be changed after restarting the device or network. In [Secure Settings] set [TLS] to [On]. Value: [Off], [On]

[REST]

Item	Description
[REST]	Set whether to send documents using REST. To use this, select [On] in these settings. The factory default port number is 9080. The setting will be changed after restarting the device or network. Value: [Off], [On] 1 to 32767 (Port Number)

[REST over TLS]

Item	Description
[REST over TLS]	<p>Select whether to communicate using REST protected by TLS. To use this, select [On] in these settings. The factory default port number is 9081.</p> <p>The setting will be changed after restarting the device or network.</p> <p>Value: [Off], [On], 1 to 32767 (Port Number)</p>

[VNC(RFB)overTLS]

Item	Description
[VNC(RFB)overTLS]	<p>Set when using a remote operation protected by TLS by starting up a VNC Viewer other than ours (example: Real VNC). The factory default port number is 9063.</p> <p>In [Security] set [TLS Setting] to [On].</p> <p>The setting will be changed after restarting the device or network.</p> <p>Value: [Off], [On], 1 to 32767 (Port Number)</p> <hr/> <p> NOTE</p> <p>If the setting is [On], a TLS certificate is required. The factory certificate is the certificate owned by the machine.</p> <p>➔ Accessing Command Center RX (page 113)</p> <hr/>

[VNC (RFB)]

Item	Description
[VNC (RFB)]	<p>Set when using a remote operation by starting up a VNC Viewer other than ours (example: Real VNC). The factory default port number is 9062.</p> <p>The setting will be changed after restarting the device or network.</p> <p>Value: [Off], [On], 1 to 32767 (Port Number)</p>

[EnhncdVNC ov TLS]

Item	Description
[EnhncdVNC ov TLS]	<p>Start Command Center RX and set for using TLS-protected remote operation. The factory default port number is 9061.</p> <p>In [Security] set [TLS Setting] to [On].</p> <p>The setting will be changed after restarting the device or network.</p> <p>Value: [Off], [On], 1 to 32767 (Port Number)</p> <hr/> <p> NOTE</p> <p>If the setting is [On], a TLS certificate is required. The factory certificate is the certificate owned by the machine.</p> <p>➔ Accessing Command Center RX (page 113)</p> <hr/>

[Secure Settings]

[System Menu/Counter] key > [▲] [▼] keys > [System/Network] > [OK] key > [▲] [▼] keys > [Network Setting] > [OK] key > [Secure Settings] > [OK] key > [TLS] > [OK] key

Set whether to use TLS for communication.

Value: [Off], [Off]

[Ping]

[System Menu/Counter] key > [▲] [▼] keys > [System] > [OK] key > [▲] [▼] keys > [Network] > [OK] key > [▲] [▼] keys > [Ping] > [OK] key

Item	Description
[Ping]	Check if you can communicate with the destination by entering the host name or IP address of the destination.

[Restart Network]

Item	Description
[Restart Network]	Restarts the network.

[Primary Network]

[System Menu/Counter] key > [▲] [▼] keys > [System/Network] > [OK] key > [▲] [▼] keys > [Primary Network] > [OK] key

Configure the network to use when connecting for sending function, network authentication, and extended address books.

Value: [Wi-Fi], [Wired Network]

[I/F Block Set.]

[System Menu/Counter] key > [▲] [▼] keys > [System/Network] > [OK] key > [▲] [▼] keys > [I/F Block Set.] > [OK] key

This allows you to protect this machine by blocking the interface with external devices such as USB hosts or optional interfaces.

Item	Description
[USB Host]	Block and protect the USB port and USB port (USB Host).
[USB Device]	Block and protect the USB interface connector (USB Device).
[USB Storage]	Block and protect the USB memory slot. Value: [Unblock], [Block] <hr/>  NOTE This function can be configured when the USB host is set to [Block]. <hr/>

 **IMPORTANT**

After changing the setting, restart the system or turn the machine OFF and then ON.

[SecurityQuickSet]

[System Menu/Counter] key > [▲] [▼] keys > [System] > [OK] key > [▲] [▼] keys > [SecurityQuickSet] > [OK] key

Item	Description
[SecurityQuickSet]	<p>Select security settings from levels 1 to 3 that are close to your environment, and change (customize) the functions as needed.</p> <p>Value</p> <p>[Level 1] The factory default setting.</p> <p>[Level 2] The security function of the network will change.</p> <p>[Level 3] All functions that protect the machine are enabled, and functions that do not protect the machine are disabled.</p> <hr/> <p> NOTE</p> <ul style="list-style-type: none"> • This function can be set only when logged in with administrator privileges. <ul style="list-style-type: none"> ➔ Log in as Machine Administrator or Administrator (page 109) • Restart the device or network after selecting a level for the settings to take effect. <ul style="list-style-type: none"> ➔ [Restart Network] (page 384) ➔ [Restart] (page 409) • If you change the security settings after selecting a level, the security quick setups will show as "Custom". • For more information on each security level setting, refer to the following: <ul style="list-style-type: none"> ➔ Security Quick Setup Function List (page 792)

[Data Security]

[System Menu/Counter] key > [▲] [▼] keys > [System] > [OK] key > [▲] [▼] keys > [Data Security] > [OK] key
Configure settings related to data stored in memory.

[DataSanitization]

This function returns the following information stored in the machine to the factory default.

- Address Book
- System Settings
- Fax Send/Receive/Transfer Data
- Outgoing and Incoming Fax Log
- Local Fax Station Name
- Local Fax Station Number
- Optional applications

IMPORTANT

Job box data saved in applications or SD cards cannot be deleted. If you want to erase this, you need to format the SD card.

NOTE

- Print [DataSanitization] and check that security data has definitely been erased.
➔ [\[Report Print\] \(page 369\)](#)
- You cannot cancel a process in the middle.
- Disconnect any modular or network cables before performing this operation.
- Before executing this function, set all to .
➔ [\[I/F Block Set.\] \(page 405\)](#)
- Do not turn off the power during data sanitization. If the power is turned off during erasing, erasing will be performed automatically after the power is turned on, but complete operation cannot be guaranteed.

Item	Settings
[Run Immediately]	Execute security data sanitization.
[Schedule]	The address information and image data in the machine will be completely erased at the specified time. Value: > Set [Off], [On] > the date and time If you select [OnOn], set the date and time for complete erasure. Year (2000 to 2035), Month (1 to 12), Day (1 to 31), and Hour (0 to 23).
[Device use]	After data sanitization, the usage of this machine will be restricted. Value: [Permit], [Prohibit] If [Prohibit] is selected, machine operation is disabled.

[SW Verification]

Verify the software in the machine.

Select [Start] to run the verification. If you experience any abnormalities in software verification, contact your service representative.

[Restart]

[System Menu/Counter] key > [▲] [▼] keys > [System] > [OK] key > [▲] [▼] keys > [Restart] > [OK] key

Item	Description
[Restart]	Restart the machine without turning the power switch off. Use this to deal with any unstable operation by the machine.

[Op Functions]

[System Menu/Counter] key > [▲] [▼] keys > [System] > [OK] key > [▲] [▼] keys > [Op Functions] > [OK] key

Item	Description
[Op Functions]	You can use the optional applications installed on this machine. Value: [UG-33], [ID Card] ➔ Overview of the Applications (page 759)

[Remote Serv.Set.]

[System Menu/Counter] key > [▲] [▼] keys > [System] > [OK] key > [▲] [▼] keys > [Remote Serv.Set.] > [OK] key > [Remote Services] > [OK] key

When the trouble occurs on this product, it is possible to explain the operational procedure and the troubleshooting method through the internet from our sales office by accessing the operation panel screen of this product while operating the screen.

 **NOTE**

When using the remote service settings, it is necessary to make a contract with our company. Please contact our sales office or our authorized dealer (purchase source) for the details.



[Software Version]

[System Menu/Counter] key > [▲] [▼] keys > [System] > [OK] key > [▲] [▼] keys > [Software Version] > [OK] key

Item	Description
[System]	You can check the version of the system software installed on this machine.
[Engine]	You can check the version of the engine software installed on this machine.

[FAX Server Set.]

[System Menu/Counter] key > [▲] [▼] keys > [System] > [OK] key > [▲] [▼] keys > [FAX Server Set.] > [OK] key > [FAX] > [OK] key

Item	Description
[FAX]	Select whether to use the Fax Server. Value: [Off], [OnOn]
[Address Settings]	Set the prefix, suffix and domain name to attach to the destination. <hr/>  NOTE For information about the fax server, contact the fax server administrator. <hr/>
[File Format]	Set the default type of the files. Value: [PDF], [TIFF], [XPS]
[AddrBookDefaults]	Set an Address Book to use. Value: [Address Book], [Ext Address Book] <hr/>  NOTE <ul style="list-style-type: none"> • Displayed when [OnOn] is set on the fax server. • If the extended address book is not set, [Ext Address Book] is not displayed. <p>➔ Command Center RX User Guide</p> <hr/>

[Managed by Admin]

[System Menu/Counter] key > [▲] [▼] keys > [System] > [OK] key > [▲] [▼] keys > [Managed by Admin] > [OK] key

Item	Description
[Managed by Admin]	If you are the same user of this machine as the administrator, such as at home or in a small office, you will be able to use functions that require logging in as an administrator without logging in. Value: [Yes], [No]

[Remote Operation]

[System Menu/Counter] key > [▲] [▼] keys > [System] > [OK] key > [▲] [▼] keys > [Remote Operation] > [OK] key > [Remote Ope. Set.] > [OK] key

Item	Description
[Remote Ope. Set.]	Set whether to use Remote Operation. Value: [Off], [On]
[Use Restriction]	Set usage authority. Set value: [Off] Users with no administrator privileges can perform remote operation. [Use Password] Enter the password for remote operation. [Admin. Only] Only administrators can perform remote operations.
[VNC Comp. Soft]	Display whether VNC compatible software can be used.

**NOTE**

- This setting is available when [Remote Ope. Set.] is [On].
- If you selected [Admin. Only], remote operation from VNC software is not possible.

[Admin FW Update]

[System Menu/Counter] key > [▲] [▼] keys > [System] > [OK] key > [▲] [▼] keys > [Admin FW Update] > [OK] key

Item	Description
[FW Update Tool]	Set whether to allow firmware updates using the firmware update tool. Value: [Permit], [Prohibit]

[FW Update Tool]

[System Menu/Counter] key > [▲] [▼] keys > [System] > [OK] key > [▲] [▼] keys > [FW Update Tool] > [OK] key

Value: [Permit], [Prohibit]

[Allowlisting]

[System Menu/Counter] key > [▲] [▼] keys > [System] > [OK] key > [▲] [▼] keys > [Allowlisting] > [OK] key

Item	Description
[Allowlisting]	<p>In case if the unauthorized program or the program that has tampered are installed, the stored data or the contents of the communication in this program might be stolen. Once this function is activated, execution of the unauthorized software or the tampering of the software can be prevented, and possible to maintain the reliability of the system.</p> <p>Value: [On], [Off]</p> <hr/> <p> NOTE</p> <ul style="list-style-type: none"> • After setting it to [On], you need to shutdown and restart the machine. • Enabling this feature slows the machine start-up. • If malware is detected, an event report can be used as a way to understand its content. The Event reports can be enable by the Command Center RX > "Notification/Report" > [Recipient 1 E-mail Address] to [Recipient 3 E-mail Address] and [Notify when Malicious Program is Detected] is set to [On]. <hr/>

Rem. Print Jobs

[System Menu/Counter] key > [▲] [▼] keys > [System] > [OK] key > [▲] [▼] keys > [Rem. Print Jobs] > [OK] key

Item	Description
[Rem. Print Jobs]	These settings are for print jobs that require security considerations, such as passwords. If you select [Cancel], any user attempts to log out will be aborted, including any jobs waiting to print. Value: [Cancel], [Continue]

[Secure Boot]

[System Menu/Counter] key > [▲] [▼] keys > [System] > [OK] key > [▲] [▼] keys > [Secure Boot] > [OK] key

Item	Description
[Secure Boot]	Secure Boot is a function that detects tampering with the BIOS or firmware when starting the machine. It verifies the electronic signature given to the BIOS or firmware, and stops the execution of the BIOS or firmware if tampering is detected. Value: [BIOS + Firmware], [BIOS]

[Import/Export]

[System Menu/Counter] key > [▲] [▼] keys > [System] > [OK] key > [▲] [▼] keys > [Import/Export] > [OK] key

Item	Description
[Import/Export]	Request approval from the administrator when importing/exporting data. Value: [OffOff], [OnOn]

[User/Job Account]

[System Menu/Counter] key > [▲] [▼] keys > [User/Job Account] > [OK] key >

Value: [User Login Set.], [Job Account.Set.]

Configures settings related to machine management.

[User Login Set.]

Item	Description
[User Login]	Value: [Off], [Local Authentic.], [Netwk Authentic.] [Netwk Authentic.] Value: [NTLM] > [Use default host] > host name, [for each domain] > host name [Kerberos] > [Use default host] > host name, [for each domain] > host name, [Ext.] > host name
[Local User List]	Value: [Admin], [DeviceAdmin] [Menu] Value: [Detail/Edit] > [Edit] Edit user name [Delete] > [Yes], [No] [Add User] > Add user name
[Local Authoriz.]	Value: [Off], [On]
[Account Lockout]	Value: [Lockout], [Lockout Policy] [Lockout] Value: [Off], [On] [Lockout Policy] Value: [Number ofRetries] > 1 - 10 times, [Lockout Duration] > 1 - 60 minutes, [Lockout Duration] > [All], [Remote Only]
[Password Policy]	Value: [Password Policy] > [Off], [On]
[ID Card Settings]	Value: [Key Login], [Additional Auth.] [Key Login] Value: [Permit], [Prohibit] [Additional Auth.] Value: [Off], [On]
[Guest Auth. Set.]	Value: [Guest Auth.], [Guest Property] [Guest Auth.] Value: [Off], [On] [Guest Property] > [Edit] > Edit user name
[QuickJobPrinting]	[DispListOnLogin] Value: [Off], [On]

[Job Account.Set.]

Item	Description
[Job Accounting]	Value: [Off], [On]
[AccountingAccess]	Value: [Local], [Network]
[Account. Report]	Value: [Yes], [No]

Item	Description
[Total JobAccounting]	Value: [Printed Pages], [Scanned Pages], [FAX TX Pages], [FAX TX Time], [Counter Reset] [Printed Pages] Value: [Copy/Print Pages], [FAX RX Pages], [Total PrintPages], [Duplex Pages], [Combine Pages] [Counter Reset] > [Yes], [No]
[Each Job Account]	[Others] Value: [Printed Pages], [Scanned Pages], [FAX TX Pages], [FAX TX Time], [Counter Reset] [Printed Pages] Value: [Copy/Print Pages], [FAX RX Pages], [Total PrintPages], [Duplex Pages], [Combine Pages]
[Account. List]	[Menu] Value: [Detail/Edit], [Delete], [Add Account] > Add department name
[Default Setting]	Value: [Apply Limit], [Copy/Print Count], [Counter Limit] [Apply Limit] Value: [Immediately], [Subsequently], [Alert Only] [Copy/Print Count] Value: [Total], [Individual] [Counter Limit] Value: [Copy Restrict.] > 1 - 9999999 , [Print Restrict.] > 1 - 9999999, [ScanRest.(Other)] > 1 - 9999999, [FAX Restrict.] > 1 - 9999999

[Unknown User]

Item	Description
[Unknown ID Job]	Value: [Reject], [Permit]

➔ [Overview of User Login Administration \(page 482\)](#)

➔ [Overview of Job Accounting \(page 515\)](#)

➔ [Unknown User Settings \(page 537\)](#)

[User Property]

[System Menu/Counter] key > [▲] [▼] keys > [User Property] > [OK] key

View information about the currently logged-in user and modify some information.

➔ [Enable User Login Administration \(page 484\)](#)

[Common Settings]

Configure overall machine operation.

Details are below.

Item	Description
[Language]	Set the language to use for the message display, and select inch or metric for the unit for paper dimensions. ➔ [Language] (page 426)
[Default Screen]	Select the screen appearing right after start-up (default screen). ➔ Default Screen (page 427)
[Sound]	Set options for buzzer sound during the machine operations. ➔ [Sound] (page 428)
[Display Bright.]	Set the brightness of the message display. ➔ Display Bright. (page 429)
[Orig./Paper Set.]	Configure the original and paper settings. ➔ [Orig./Paper Set.] (page 432)
[Preset Limit]	Restrict the number of copies that can be made at one time. ➔ Preset Limit (page 438)
[Measurement]	Select inch or metric for the unit for paper dimensions. ➔ Measurement (page 439)
[Error Handling]	Select whether to cancel or continue the job when error has occurred. ➔ [Error Handling] (page 440)
[Date/Time]	Configures settings related to the date and time. ➔ [Date/Time] (page 441)
[Timer Setting]	Configures settings related to the time. ➔ [Timer Setting] (page 442)
[Function Default]	Set the defaults for functions for this machine. ➔ [Function Default] (page 445)
[Login Operation]	Select the login user name/login password entry screen to be used during login. ➔ Login Operation (page 452)
[RAM Disk Mode]	Create a RAM disk and set its capacity. ➔ [RAM Disk Mode] (page 453)
[Format SD Card]	Format the SD card. ➔ Format SD Card (page 454)
[Disp. Status/Log]	Set the display of Job Status/Jobs History. ➔ [Disp. Status/Log] (page 455)
[Keyboard Lang.]	Select the keyboard input language. ➔ Keyboard Lang. (page 456)

Item	Description
[Keyboard Type]	Select the keyboard input language. ➔ [Keyboard Type] (page 457)
[Low Toner Alert]	Set the amount of remaining toner to notify the administrator when to order a toner when the toner is running low. ➔ Low Toner Alert (page 458)
[MaintenanceAlert]	Set the timing at which the administrator will be notified of the period remaining before the upcoming scheduled inspection when it is near. ➔ [MaintenanceAlert] (page 459)
[Remote Printing]	Select whether to prohibit printing that is performed without operating the machine. ➔ [Remote Printing] (page 460)
[Direct PRN (Web)]	Set whether to allow Direct Printing from Command Center RX. ➔ [Direct PRN (Web)] (page 461)
[Show PowerOffMsg]	Set the mode whether display a confirmation message in power supply off. ➔ Show PowerOffMsg (page 462)
[EnergySaver Set.]	Configure the Energy Saver settings. ➔ EnergySaver Set. (page 463)
[Pause/Resume Set]	Select whether to permit for the pausing or resuming of all printing. ➔ [Pause/Resume Set] (page 464)
[CloudConnectSet.]	Select whether to permit for coordination between this product and our company's cloud service. ➔ CloudConnectSet. (page 465)

[Language]

[System Menu/Counter] key > [▲] [▼] keys > [Common Settings] > [OK] key [▲] [▼] keys > [Language] > [OK] key

Value: [English], [German], [French], [Spanish], [Italian], [Dutch], [Russian], [English]

[Default Screen]

[System Menu/Counter] key > [▲] [▼] keys > [Common Settings] > [OK] key > [▲] [▼] keys > [Default Screen] > [OK] key

Value: [Status], [Copy], [Send], [FAX], [Document Box]

[Sound]

[System Menu/Counter] key > [▲] [▼] keys > [Common Settings] > [OK] key > [▲] [▼] keys > [Sound] > [OK] key

Value: [Buzzer], [FAX Speaker], [FAX]

[Display Bright.]

[System Menu/Counter] key > [▲] [▼] keys > [Common Settings] > [OK] key > [▲] [▼] keys > [Image Quality] > [OK] key

Value: [Darker -3], [Darker -2], [Darker -1], [Normal 0], [Lighter +1], [Lighter +2], [Lighter +3]

[Media Type Set.]

[System Menu/Counter] key > [▲] [▼] keys > [Common Settings] > [▲] [▼] keys > [Orig./Paper Set.] > [▲] [▼] keys > [Media Type Set.] [OK] keys

Select weight for each media type.

The following media type and paper weight combinations are available.

Paper Weight	Weight (g/m ²) and Media Type
Light	52 g/m ² to 59 g/m ²
Normal 1	60 g/m ² to 74 g/m ²
Normal 2	75 g/m ² to 90 g/m ²
Normal 3	91 g/m ² to 105 g/m ²
Heavy 1*1	106 g/m ² to 135 g/m ²
Heavy 2*1	136 g/m ² to 163 g/m ²
Heavy 3*1	164 g/m ² to 220 g/m ²

*1 The processing speed will be slower than normal.

Each media type's default weight is indicated.

Media Type	Default
[Plain]	[Normal 1]
[Vellum]	[Normal 1]
[Labels]	[Heavy 1]
[Recycled]	[Normal 1]
[Preprinted]	[Normal 2]
[Bond]	[Normal 3]
[Cardstock]	[Heavy 3]
[Color]	[Normal 1]
[Prepunched]	[Normal 1]
[Letterhead]	[Normal 2]
[Envelope]	[Heavy 2]
[Thick]	[Heavy 2]
[Coated]	[Normal 3]
[High Quality]	[Normal 1]
[Custom 1] to [Custom 8]	[Normal 1]

For [Custom 1] to [Custom 8], settings for duplex printing and media type name can be changed.

[Duplex Printing]

Item	Description
[Permit]	Duplex printing allowed.
[Prohibit]	Duplex printing not allowed.

[Name]

Change names for Custom 1-8. Names should be not more than 16 characters. Selecting media type at multipurpose tray, the name after change will be displayed.

➔ [Character Entry \(page 761\)](#)

[Orig./Paper Set.]

Custom Orig.Size

Configure settings for originals. Set up frequently-used custom original size. The custom size option is displayed on the screen to select original size.

[System Menu/Counter] key > [▲][▼] keys > [Common Settings] > [OK] key > [▲][▼] keys > [Orig./Paper Set.] > [OK] key > [▲][▼] > [Custom Orig.Size] > [OK] key

Value

Metric

X: 50 to 356 mm (in 1 mm increments)

Y: 50 to 216 mm (in 1 mm increments)

Inch

X: 1.97 to 14.02" (in 0.01" increments)

Y: 1.97 to 8.50" (in 0.01" increments)

X=Length, Y=Width

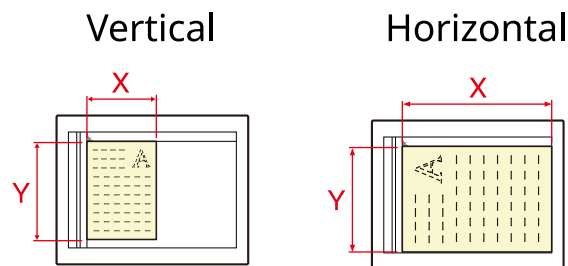

Detect Orig.(DP)

Set whether to use the document processor to detect the original size. Platen cannot automatically detect the original size.

[System Menu/Counter] key > [▲][▼] keys > [Common Settings] > [OK] key > [▲][▼] keys > [Orig./Paper Set.] > [OK] key > [▲][▼] keys > [Detect Orig.(DP)] > [OK] key

Item	Description
[Auto Detect]	<p>[Detect Std.Size]</p> <p>Select whether to enable automatic detection of the Standard Size. The size that can be detected is A6, B6, A5, B5, A4, and Folio in the case of centimeter size. For inch size, Statement, Letter, and only one of Legal, Officio II, or 216mm x 340mm.</p> <p>Value: [OffOff], [OnOn]</p> <p>[Non-Std.(Copy)]</p> <p>Set whether to detect non-standard size documents in the copy function. This setting takes precedence over the automatic (standard size) setting.</p> <p>Value: [OffOff], [OnOn]</p> <p>[Non-Std.(Send)]</p> <p>Set whether to detect non-standard size documents in the send or save function. This setting takes precedence over the automatic (standard size) setting.</p> <p>Value: [OffOff], [OnOn]</p>
[System of Units]	<p>Select [Metric]Metric when automatically detecting the originals in centimeter sizes. Select [Inch] when detecting the originals in inch sizes.</p> <p>Value: [Metric], [Inch]</p>
[LGL / OFII / 216 x 340]	<p>Since the third item options to be auto detected in inch are similar in size, set which size to use.</p> <p>This function is displayed when [Inch] is set to "System of Units".</p> <p>Value: [Legal], [OficioII], [216 x 340 mm]</p>

[Def. Orig. Size]

Set the default value for the original size.

[System Menu/Counter] key > [▲][▼] keys > [Common Settings] > [OK] key > [▲][▼] keys > [Orig./Paper Set.] > [OK] key > [▲][▼] keys > [Def. Orig. Size] > [OK] key

Value

[OffOff]^{*1}, [A4],[A5], [A6], [B5], [B6],[Folio], [16 × 340 mm], [letter], [Legal], [Statement], [Executive], [OficioII], [16K], [ISO B5], [Envelope #10], [Envelope #9], [Envelope #6], [Envelope Monarch], [Envelope DL], [Envelope C5], [Cardstock], [Oufuku], [Youkei 4], [Youkei 2], [Nagagata 3], [Nagagata 4], [Younaga 3]

*1: It is displayed when [Auto Detect] > [Detect Std.Size] of [Detect Orig.(DP)] is set to [OnOn].

[Custom PaperSize]

[System Menu/Counter] key > [▲][▼] keys > [Common Settings] > [OK] key > [▲][▼] keys > [OK] key > [▲][▼] keys > [Custom PaperSize] > [OK] key

Set up frequently-used custom paper size. Register one custom size for each paper source. The registered size is displayed when the paper size is selected.

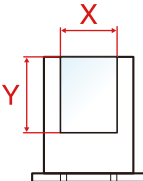
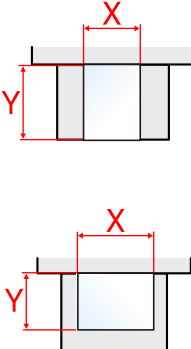
Item	Description
[Cassette 1 Size] to [Cassette 3 Size]	<p>Register the custom size to be used in Cassette 1 to Cassette 3.</p> <p>Value:</p> <p>Metric</p> <p>X: 105 to 216 mm (in 1 mm increments)</p> <p>Y: 148 to 356 mm (in 1 mm increments)</p> <p>Inch</p> <p>X: 4.13 to 8.50" (in 0.01" increments)</p> <p>Y: 5.83 to 14.02" (in 0.01" increments)</p> <p>X=Length, Y=Width</p> 
[MF Tray Size]	<p>Register the custom size to be used in MP Tray.</p> <p>Value:</p> <p>Metric</p> <p>X: 70 to 216 mm (in 1 mm increments)</p> <p>Y: 148 to 356 mm (in 1 mm increments)</p> <p>Inch</p> <p>X: 2.76 to 8.50" (in 0.01" increments)</p> <p>Y: 5.83 to 14.02" (in 0.01" increments)</p> <p>X=Length, Y=Width</p> 

[Cassette 1 Set.] to [Cassette 3 Set.]

[System Menu/Counter] key > [▲][▼] key > [Common Settings] > [OK] key > [▲][▼] key > [Orig./Paper Set.] > [OK] key > [▲][▼] key > [Cassette 1 Set.] [Cassette 3 Set.] > [OK] key

Set the size of paper used in cassettes 1 to 3.

Item	Description
[Cassette 1 Size] to [Cassette 3 Size]	Select the paper size. [A4], [A5-R], [A5], [A6], [B5], [letter], [Legal], [Statement], [Executive], [Oficio II], [Folio] [216 x 340 mm], [16K], [ISO B5] [Custom]
[Cassette 1 Type] to [Cassette 3 Type]	Select the media type. Value: [Plain], [Vellum], [Recycled], [Preprinted], [Bond], [Color], [Prepunched], [Letterhead], [Thick], [High Quality], [Custom 1] to [Custom 8] <ul style="list-style-type: none"> • To change to a media type other than "Plain" refer to the following. ➔ [Media Type Set.] (page 430) • When a paper weight that cannot be loaded in the cassette is set for a media type, that media type does not appear. • To print on Preprinted, Prepunched or Letterhead, refer to the following: ➔ SpecialPaper Act. (page 436)

[MF Tray Set.]

[System Menu/Counter] key > [▲][▼] keys > [Common Settings] > [OK] key > [▲][▼] keys > [Orig./Paper Set.] > [OK] key > [▲][▼] keys > [MF Tray Set.] > [OK] key

Value

[MF Tray Size]: A4, A5, A5-R, A6, B5, B6, Folio, 216 x 340 mm, Letter, Legal, Statement, Executive, Oficio II, 6K, ISO B5, Envelope #10, Envelope #9, Envelope #6, Envelope Monarch, Envelope DL, Envelope C5, Cardstock, Oufuku, youkei 4, youkei 2, Youkei 3, nagagata 3, nagagata 4, Custom

[MF Tray Type]: Plain, Transparency (OHP film), Vellum, lLabels, Recycled, Preprinted Bond, Hagaki, Color, Prepunched, Letterhead, Envelope, Thick, High Quality, Custom 1 Custom 8

[Media Type Set.]

The following media type and paper weight combinations are available.

For Custom 1 to 8, settings for duplex printing and media type name can be changed.

➔ [\[Media Type Set.\] \(page 430\)](#)

[Media for Auto]

When Auto is selected for Paper Selection, you can limit the paper that is automatically selected by paper type. For example, if [Plain] is selected, the paper source with plain paper loaded in the specified size is selected. Select [All Media Types] for the paper source with any kind of paper loaded in the specified size.

Value: All Media Types, Plain, Transparency (OHP film), [Vellum], Labels, Recycled, Preprinted, Bond, Cardstock, Color, Prepunched, Letterhead, Envelope, Thick, High Quality, Custom 1 to 8

[Def. PaperSource]

Select the default paper source.

Value: Cassette 1 to Cassette 3, MP Tray

NOTE

[Cassette 2] to [Cassette 3] are displayed when the optional paper feeder is installed.

[SpecialPaper Act.]

When printing on Prepunched, Preprinted, and Letterhead, punch-holes might not be aligned or the print direction might be upside-down due to a combination of copying functions and the way originals are set. In such a case, select [Adj. PrintDirect] to adjust the print direction. When paper orientation is not important, select [Speed Priority]. If [Adj. PrintDirect] is selected, load paper according to the steps below.

Example: copying on Letterhead

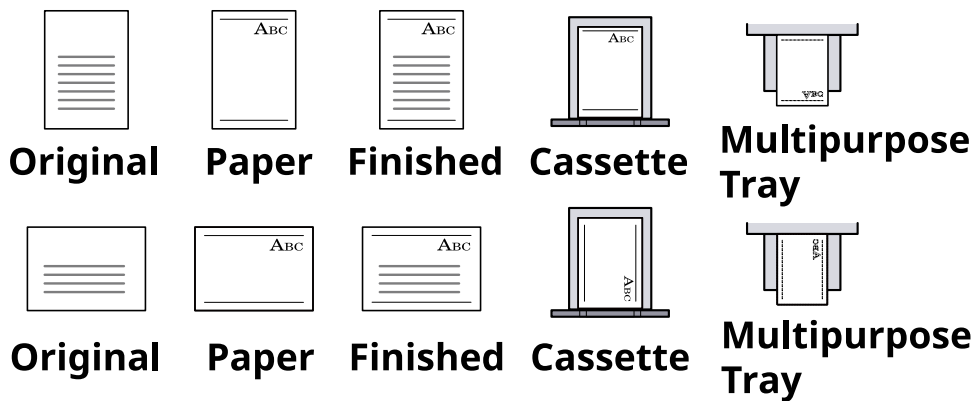

[Paper Setup Msg]

[System Menu/Counter] key > [▲] [▼] keys > [Paper Settings] > [OK] key > [Paper Setup Msg] > [OK] key

Set whether to display the confirmation screen for the paper setting when a new paper is set for each cassette.

Item	Description
[Cassette 1] to [Cassette 3] [MP Tray]	Value: [Off], [On] <hr/>  NOTE [Cassette 2] to [Cassette 3] are displayed when the following optional paper feeder is installed. [Cassette 2]: Paper Feeder (250-sheet) [Cassette 3]: Paper Feeder (250-sheet)

[Preset Limit]

Restrict the number of copies that can be made at one time.

[System Menu/Counter] key > [▲] [▼] keys > [Common Settings] > [OK] key [▲] [▼] keys > [Preset Limit] > [OK] key

Value: 1 to 999 copies

[Measurement]

Select inch or millimeter for the unit for paper dimensions.

[System Menu/Counter] key > [▲] [▼] keys > [Common Settings] > [OK] key [▲] [▼] keys > [Measurement] > [OK] key

Setting value: Inch, mm

[Error Handling]

[System Menu/Counter] key > [▲][▼] keys > [Common Settings] > [OK] key [▲][▼] keys > [Error Handling] > [OK] key

Item	Description
[DuplexPaperError]	Set what to do when duplex printing is not possible for the selected paper sizes and media types. Value [1-sided]: Printed in 1-sided. [Display Error]: Message to cancel printing is displayed.
[PaperMismatchErr]	Set what to do when the selected paper size or type does not match paper size or type loaded in the specified paper source while printing from the computer by specifying the cassette or multipurpose tray. Value [Ignore]: The setting is ignored and the job is printed. [Display Error]: Message to cancel printing is displayed.
[Permission]JobErr]	Set which users can cancel or continue operations for jobs which were paused due to an error. Value: [All Users], [Job Owner Only] <hr/>  NOTE Administrator can cancel all jobs regardless of this setting. <hr/>

[Date/Time]

[System Menu/Counter] key > [▲] [▼] keys > [Common Settings] > [OK] key [▲] [▼] keys > [Date Setting] > [OK] key

Configures settings related to the date and time.

Item	Description
[Date/Time]	<p>Set the date and time for the location where you use the machine. If you perform Send as Email, the date and time set on the machine will be displayed on the header.</p> <p>Value: [Year] (2000 to 2035), [Month] (1 to 12), [Day] (1 to 31), [Hour] (00 to 23), [min.] (00 to 59), [sec.] (00 to 59)</p> <p>➔ Setting Date and Time (page 67)</p> <hr/> <p> NOTE</p> <p>If you change the date/time while using the trial version of an application, you will no longer be able to use the application.</p>
[Date Format]	<p>Select the display format of year, month, and date. The year is displayed in Western notation.</p> <p>Value: [Month/Day/Year], [Day/Month/Year], [Year/Month/Day]</p>
[Time Zone]	<p>Set the time difference from GMT. Choose the nearest listed location from the list.</p> <p>If you select a region that utilizes summer time, configure settings for summer time.</p> <p>➔ Setting Date and Time (page 67)</p>

[Timer Setting]

[System Menu/Counter] key > [▲][▼] keys > [Common Settings] > [OK] key [▲][▼] keys > [Timer Setting] > [OK] key

Configures settings related to the time.

[Auto Panel Reset]

If no jobs are run for a certain period of time, automatically reset settings and return to the default setting. Select to use Auto Panel Reset or not.

Value: [Off], [On]

NOTE

For setting the time until the panel is automatically reset, refer to [PanelReset Timer].

→ [PanelReset Timer \(page 442\)](#)

[PanelReset Timer]

If you select On for Auto Panel Reset, you can set the amount of time to wait before Auto Panel Reset.

Value: 5 to 495 seconds (in 5 second increments)

NOTE

This function is displayed when is set to On.

[Sleep Level]

You can set the sleep level.

Item	Description
[Energy Saver][Quick Recovery]	<p>Set the Energy Saver mode to reduce power consumption even more than normal Sleep mode.</p> <hr/> <p> NOTE</p> <p>Use the Quick Recovery mode only when the computer does not recognize USB-connected devices. Note that this will consume more power.</p> <hr/>

Item	Description
[Sleep Rules]	<p>Select whether to use the Energy Saver mode for the following functions individually:</p> <ul style="list-style-type: none"> • When connecting IC Card Reader. Displayed when the optional Card Authentication Kit is activated. Value: [Off], [On] • Application • When connected by fax Value: [Off], [On] <hr/> <p> NOTE</p> <p>When the machine has entered sleep mode with Energy Saver setting, the ID card cannot be recognized.</p> <hr/>

[Sleep Timer]

Set amount of time before entering Sleep.

Value: 1 to 60 minutes (1 minute increments)

➔ [Sleep \(page 81\)](#)

Power Off Timer

Select whether to turn off the power automatically after a period of inactivity.

Value: [1 hour], [2 hours], [3 hours], [4 hours], [5 hours], [6 hours], [9 hours], [12 hours], [1 day], [2 days], [3 days], [4 days], [5 days], [6 days], [1 week]

[Auto Err. Clear]

If an error occurs during processing, processing stops to wait for the next step to be taken by the user. In the Auto Error Clear mode, automatically clear the error after a set amount of time elapses.

Value: [Off], [On]

[Err. Clear Timer]

If you selected Auto Error Clear, set the amount of time to wait before automatically resuming printing.

Value: 5 to 495 seconds (in 5 second increments)

NOTE

This setting is available when [Err. Clear Timer] is [On].

[Unusable Time]

Set a time period during which the machine will not print received faxes.

➔ **FAX Operation Guide**

[Ping Timeout]

Set the time until timeout occurs when "Network Setting" is executed in [Ping].

Value: 1 to 30 seconds (in 1 second increments)

[Function Default]

[System Menu/Counter] key > [▲][▼] > [Common Settings] > [OK] key > [▲][▼] > [Function Default] > [OK] key

[Def.Orig.(Copy)]

Item	Description
[Def.Orig.(Copy)]	<p>Set the default value for the original size when copying.</p> <p>If [Auto(Non-Std.)] in [Common Settings] > [Orig./Paper Set.] > [Detect Orig.(DP)] > [Auto Detect] is [OffOff], the size set in the default document size is displayed as a selection.</p> <p>Value: [Auto(Non-Std.)], [A4]</p>

[Def.Orig.(Send)]

Item	Description
[Def.Orig.(Send)]	<p>Set the default value for the original size when sending.</p> <p>If [Detect Std.Size] in [Common Settings] > [Orig./Paper Set.] > [Detect Orig.(DP)] > [Auto Detect] is [OffOff], the size set in the default document size is displayed as a selection.</p>

[DuplexOrg(Copy)]

Item	Description
[DuplexOrg(Copy)]	<p>Set the default value for the original size when copying.</p> <p>Value: [1-sided], [Duplex]</p>

[DuplexOrg(Send)]

Item	Description
[DuplexOrg(Send)]	<p>Set the default value for double-sided originals when sending.</p> <p>Value: [1-sided], [Duplex]</p>

[Duplex Printing]

Item	Description
[Duplex Printing]	<p>Sets the default value for printing (single-sided or double-sided printing).</p> <p>Value: [1-sided], [Duplex]</p>

[Color Selection]

Item	Description
[Color Selection]	Select the default color mode for scanning documents. Value: [Auto (Color/Gray)], [Auto (Color/B & W)], [Full Color], [Grayscale], [Black & White]

[Scan Resolution]

Item	Description
[Scan Resolution]	Select the default scanning resolution for scanning documents. Value: [200x100dpi Normal], [200x200dpi Fine], [200x400dpi S.Fin], [300x300dpi], [400x400dpi U.Fin], [600x600dpi]

[FAX Resolution]

→ **FAX Operation Guide**

[Orig.Image(Copy)]

Item	Description
[Orig.Image(Copy)]	Set the default original document type for copying. Value: [Text+Photo], [Photo], [Text], [Graphic/Map]

[Orig.Image(Send)]

Item	Description
[Orig.Image(Send)]	Set the default original document type(when sending). Value: [Text+Photo], [Photo], [Text], [for OCR], [Light Text/Line]
	 NOTE [for OCR] is a color selection and is only available when [Auto (Color/B & W)] or [Black & White] is selected.

[Zoom]

Item	Description
[Zoom]	Select the enlarged/reduced default when paper size/sending size changed after the originals set. Value: [100%], [Auto]

[Collate]

Item	Description
[Collate]	Set the defaults for Collate. Value: [OffOff], [OnOn]

[Orig.Orientation]

Item	Description
[Orig.Orientation]	Set the original orientation defaults. Value: [Top Edge on Top], [Top Edge on Left]

[Backgrnd(Copy)]

Item	Description
[Backgrnd(Copy)]	Set the default Background Density (Copy). Value: [OffOff], [Auto], [Manual(Darker 5)]

[Backgrnd(Send)]

Item	Description
[Backgrnd(Send)]	Set the default Background Density (when sending). Value: [OffOff], [Auto], [Manual(Darker 5)]

[EcoPrint]

Item	Description
[EcoPrint]	Select the EcoPrint default. Value: [OffOff], [OnOn]

[Prevent B-t Copy]

Item	Description
[Prevent B-t Copy]	Set the default value for preventing bleed-through (Copy). Value: [OffOff], [OnOn]

[Prevent B-t Send]

Item	Description
[Prevent B-t Send]	Set the default value for preventing bleed-through (when sending). Value: [OffOff], [OnOn]

[Border Erase def]

[System Menu/Counter] key > [▲] [▼] > [Common Settings] > [OK] key > [▲] [▼] > [Function Default] > [OK] key > [▲] [▼] > [Border Erase def] > [OK] key

Item	Description
[B Erase Copy]	Set the defaults for B Erase Copy. Value: [Standard], [Collate], [Book], [Individual]
[B Erase Send]	Set the defaults for B Erase Send. Value: [Standard], [Full Scan], [Collate], [Book], [Individual]
[B Erase FAX]	Set the defaults for B Erase FAX. [Standard], [Full Scan], [Collate], [Book], [Individual]
[Border]	To specify border erase widths around original, set the defaults for the border erase width of the outer frame. Value: [Centimeter]: 0 to 50 mm (in 1 mm increments) [Inch]: 0 to 2" (in 0.01" increments)
[Gutter]	To specify border erase widths in the center of the original, set the defaults for the border erase width of the middle frame. Value: [Centimeter]: 0 to 50 mm (in 1 mm increments) [Inch]: 0 to 2" (in 0.01" increments)
[Back Page]	Select the Border Erase Method for Back Page of a sheet. Value: [Same as Front], [Do Not Erase]

[Skip Blank(Copy)]

Item	Description
[Skip Blank(Copy)]	Select the default Skip Blank(Copy) setting. Value: [OffOff], [OnOn]

[Skip Blank(Send)]

Item	Description
[Skip Blank(Send)]	Select the default Skip Blank(Send) setting. Value: [OffOff], [OnOn]

[File Name Entry]

Item	Description
[File Name Entry]	Set an automatically entered name (default) for jobs. Additional information such as Date and Time and Job No. can also be set. Value: [FileName]: Up to 32 characters can be entered. [Additional Info.], [None], [Date], [Job No.], [Job No. + Date], [Date + Job No.]

[Subject/Body]

Item	Description
[Subject/Body]	Set the subject and body automatically entered (default subject and body) when sending the scanned originals by E-mail. Value: [Subject]: Up to 60 characters can be entered. [Body]: Up to 500 characters can be entered.

[Con.scan-Copy]

Item	Description
[Con.scan-Copy]	Select the default Continuous Scan (Copy) setting. Value: [OffOff], [OnOn]

[Con.scan-FAX]

➔ [FAX Operation Guide](#)

[Con.scan-Others]

Item	Description
[Con.scan-Others]	Set the default for continuous scanning other than copy and fax. Value: [OffOff], [OnOn]

[File Format]

Item	Description
[File Format]	Set the default type of the files. Value: [PDF] > [TIFF], [XPS], [JPEG], [OpenXPS], [High Comp.PDF]

[File Separation]

Item	Description
[File Separation]	Select the default file separation setting. Value: [OffOff], [Each Page]

[JPEG/TIFF Print]

Item	Description
[JPEG/TIFF Print]	Select the image size (resolution) when printing JPEG or TIFF file. Value: [Paper Size], [Image Resolution], [Print Resolution]

[XPS FitTo Page]

Item	Description
[XPS FitTo Page]	Set the default value for the XPS fit to page function. Value: [OffOff], [OnOn]

[FoldingDetection]

Item	Description
[FoldingDetection]	If you select [OnOn], when scanning a document from the document processor, scanning is automatically stopped when a document with a folded corner is detected. Value: [OffOff], [OnOn]

[Clarify Text]

Item	Description
[Clarify Text]	When scanning and sending a document in black and white, it eliminates background noise and improves the legibility of the text. Value: [OffOff], [OnOn]

[ID Card Copy]

Select the default ID Card Copy setting.

Item	Description
[ID Card Copy]	No card position specified or set it to top left. Value: [Free], [Upper Left]
Layout[Layout]	Sets the copy position on the paper to center or top right. Value: [Align UpperRight], [Align Center]

[Clear Job Set.]

Item	Description
[Clear Job Set.]	Set whether to reset function settings to their defaults after the job starts. Value: [Clear], [Do Not Clear]

[Detail Setting]

Item	Description
[2 in 1 Layout]	Sets the defaults when a 2-in-1 layout is selected for page aggregation. Value: [L to R], [T to B], [R to L], [B to T]
[4 in 1 Layout]	Sets the defaults when a 4-in-1 layout is selected for page aggregation. Value: [Right then Down], [Down then Right], [Left then Down], [Down then Left]
[Border Line]	Set the defaults for the page aggregation border. Value: [None], [Solid Line], [Dotted Line],
[Orig. Bind(Copy)]	Set the default binding orientation for double-sided scanning (copy). Value: [Left/Right], [Top]
[Orig. Bind(Send)]	Set the default binding orientation for double-sided scanning (Send). Value: [Left/Right], [Top]
[Finish. Binding]	Select default binding orientation for duplex mode. Value: [Left/Right], [Top]
[Image Quality]	Sets the default quality for PDF/TIFF/JPEG/XPS/OpenXPS files. Value: [1 Low(High Comp)] to [5 High(Low Comp)]
[Color TIFF Comp.]	Set the defaults for compression method for TIFF images. Value: [TIFF V6], [TTN2]
[PDF/A]	Select the default PDF/A setting. Value: [OffOff], [PDF/A-1a], [PDF/A-1b]
[High Comp.PDF]	Select the default PDF/A setting. Value: [Comp. Priority], [Normal], [Quality Priority]
[ItemsToSkip Copy]	Set the defaults for the blank page detection level (Copy). Value: [Blank+Ruled Line], [Blank Pages Only], [Blank+Some Text]
[ItemsToSkip Send]	Set the defaults for the blank page detection level (Send). Value: [Blank+Ruled Line], [Blank Pages Only], [Blank+Some Text]

[Login Operation]

[System Menu/Counter] key > [▲] [▼] keys > [Common Settings] > [OK] key [▲] [▼] keys > [Login Operation] > [OK] key

Select the login user name/login password entry screen to be used during login.

Value: [Use Numeric Key], [Select Character]

[RAM Disk Mode]

[System Menu/Counter] key > [▲] [▼] keys > [Common Settings] > [OK] key [▲] [▼] keys > [RAM Disk Mode] > [OK] key

Create a RAM disk and set its capacity.

You can print print data from the job box by creating a RAM disk.

Value: [Off], [On]

If you select [On], you can set the [RAM Disk Size]. Setting range varies depending on size of onboard memory.

IMPORTANT

After changing the setting, restart the system or turn the machine OFF and then ON.

[Format SD Card]

[System Menu/Counter] key > [▲] [▼] keys > [Common Settings] > [OK] key [▲] [▼] keys > [Format SD Card] > [OK] key

Format the SD card. Displayed when the SD card is installed into this machine. To use an SD memory card, you must first use the machine to format the SD memory card.

IMPORTANT

- Formatting an SD card will erase all of its data.
 - If installing an application, the application may be deleted so do not format the SD card.
-

[Disp. Status/Log]

[System Menu/Counter] key > [▲] [▼] keys > [Common Settings] > [OK] key [▲] [▼] keys > [Disp. Status/Log] > [OK] key

[Disp. Status/Log]

Set the display of Job Status/Jobs History.

Item	Description
[JobsDetailStatus]	Value: [Show All], [My Jobs Only], [Hide All]
[Jobs Log]	Value: [Show All], [My Jobs Only], [Hide All]
[FAX Log]	Value: [Show All], [Hide All]

[Keyboard Lang.]

[System Menu/Counter] key > [▲] [▼] keys > [Common Settings] > [OK] key [▲] [▼] keys > [Keyboard Lang.] > [OK] key

Select the keyboard input language.

Value: [FollowDisp.Lang.], [English]

[Keyboard Type]

[System Menu/Counter] key > [▲] [▼] keys > [Common Settings] > [OK] key [▲] [▼] keys > [Keyboard Type] > [OK] key

Select the optional keyboard type.

Value: [US-English], [US-English w/EUR], [French], [German], [UK-English]

[Low Toner Alert]

[System Menu/Counter] key > [▲] [▼] keys > [Common Settings] > [OK] key [▲] [▼] keys > [Low Toner Alert] > [OK] key

Set the amount of remaining toner to notify the administrator when to order a toner when the toner is running low.

Value: [Off], [On]

 **NOTE**

If [Off] is selected, you will be notified when the toner level reaches 5%. If [On] is selected, set the amount of remaining toner to alert. The setting range is 5 to 100% (in 1% increments).

[MaintenanceAlert]

[System Menu/Counter] key > [▲] [▼] keys > [Common Settings] > [OK] key [▲] [▼] keys > [MaintenanceAlert]

Item	Description
[Notify via Panel]	Set whether or not to display on the operation panel when a periodic inspection is near. Value: [Off], [Message]
[NotifyExternally]	Set the timing at which the administrator will be notified of the period remaining before the upcoming scheduled inspection when it is near. This notification is used for Event Reports, Status Monitors, and SNMPTraps (such as Printing Equipment Management Systems). Value: [Off], [On] <hr/> <div data-bbox="579 741 708 788">  NOTE </div> <p data-bbox="588 824 1437 887">If is selected, set the alert timing. The setting range is 5 to 100% (in 1% increments).</p> <hr/>

[Remote Printing]

[System Menu/Counter] key > [▲] [▼] keys > [Common Settings] > [OK] key [▲] [▼] keys > [Remote Printing]

Select whether to prohibit printing that is performed without operating the machine.

When [Prohibit] is selected, a document that has been stored in the document box from the printer driver can be printed from the machine. This prevents another person from seeing that document.

Value: [Permit], [Prohibit]

[Direct PRN (Web)]

[System Menu/Counter] key > [▲] [▼] keys > [Common Settings] > [OK] key [▲] [▼] keys > [Direct PRN (Web)]

Set whether to allow Direct Printing from Command Center RX.

Value: ,

➔ **Command Center RX User Guide**

[Show PowerOffMsg]

[System Menu/Counter] key > [▲] [▼] keys > [Common Settings] > [OK] key > [▲] [▼] keys > [Show PowerOffMsg] > [OK] key

Set the mode whether display a confirmation message in power supply off.

Value: [Off], [On]

[EnergySaver Set.]

[System Menu/Counter] key > [▲] [▼] keys > [Common Settings] > [OK] key [▲] [▼] keys > [EnergySaver Set.]

[Recovery Level]

Item	Description
[Recovery Level]	<p>Select the method of recovery from energy saver.</p> <p>Value</p> <p>[Full Recovery]: This mode enables the use of all functions immediately. However, this mode saves less energy.</p> <p>[Normal Recovery]: In this mode, you can select the method from the following: enabling the use of all functions immediately or enabling the use of desired functions only. If you want to use all functions immediately, select the [Energy Saver] key to execute recovery.</p> <p>[Power Saving]: This mode enables the use of the functions that you wish to use only. This is the most energy-efficient mode.</p>

[Pause/Resume Set]

[System Menu/Counter] key > [▲] [▼] keys > [Common Settings] > [OK] key [▲] [▼] keys > [Pause/Resume Set]

Select whether to permit for the pausing or resuming of all printing.

Value: [Permit], [Not Allowed]

[CloudConnectSet.]

[System Menu/Counter] key > [▲] [▼] keys > [Common Settings] > [OK] key > [▲] [▼] keys > [CloudConnectSet.] > [OK] key

Set connection and editing restrictions for Cloud Access.

➔ [Cloud Linkage Function \(page 269\)](#)

[Copy]

[System Menu/Counter] key > [▲] [▼] keys > [Copy] > [OK] key

Item	Description
[Orig./Paper Set.]	Set the default paper selection. Value: [Auto], [Def. PaperSource]
[AutoPaperSelect.]	If [Auto] is selected for Paper Selection, set the paper size selection method for when the zoom changes. Value: [MostSuitableSize]: Selects optimum paper size based on the current zoom level and the size of the original. [Same as Orig. Size]: Selects paper that matches the size of the original, regardless of the zoom level.
[Auto % Priority]	When a paper source of different size from the original is selected, select whether automatic zoom (reduce/zoom) is performed. Value: [Off], [On]
[DP Read Action]	Set the operation when a document is scanned from the document processor. Value: [Speed Priority]: Loading speed is prioritized. [Quality Priority]: Slightly slows down the loading speed and gives priority to the quality of the original.
[Select Key Set. Folio]	You can register frequently used copy functions for the selection key. You can easily set it by selecting the selection key. Value: [None], [Paper Selection], [Collate], [ID Card Copy] [Duplex], [Zoom], [Combine], [Border Erase], [Original Size], [Orig.Orientation], [Original Image], [Density], [EcoPrint], [Continuous Scan], [File Name Entry], [JobFinish Notice], [Print Override], [Sharpness], [Contrast], [Backgrnd Density], [Prevent Bleed-t], [Erase Colors], [Skip Blank Page]

[Printer]

[System Menu/Counter] key > [▲] [▼] key > [Printer] > [OK] key



Printing from computers, settings are generally made on the application software screen. However, the following settings are available for configuring the defaults to customize the machine.

[Emulation Set.]

Item	Description
[Emulation Set.]	<p>Select the emulation for operating this machine by commands oriented to other types of printers.</p> <p>Value: [NEC PC-PR201], [IBM 5577], [EPSON VP-1000], [PCL6], [KPD L], [KPD L(Auto)]</p> <hr/> <p> NOTE</p> <p>When you have selected [KPD L] or [KPD L(Auto)], set [KPD L Error Rpt], too.</p> <hr/>
[Alt. Emulation]	<p>If you select [KPD L(Auto)] as the emulation mode, you can automatically switch between KPD L and another emulation mode (alternative emulation) depending on the data to be printed.</p> <p>Value: [PCL6]</p>
[KPD L Error Rpt]	<p>When an error has occurred during printing in KPD L emulation mode, set whether or not the error report is output.</p> <p>Value: [OffOff], [OnOn]</p>

Item	Description
[EcoPrint]	<p>EcoPrint conserves toner when printing. This is recommended for test copies where faded printing is not a problem.</p> <p>Value: [OffOff], [OnOn]</p>
[Override A4/LTR]	<p>Select whether to treat A4 size and Letter, which are similar in size, as the same size when printing.</p> <p>Value: [OffOff], [OnOn]</p>
[Duplex]	<p>Select binding orientation for duplex mode.</p> <p>Value: [OffOff], [Bind Long Edge], [Bind Short Edge]</p>
[Copies]	<p>Set the default number of copies, from 1 to 999.</p> <p>Value: 1 to 999 copies</p>
[Orientation]	<p>Set the default orientation, [Portrait] or [Landscape].</p> <p>Value: [Portrait], [Landscape]</p>
[Wide A4]	<p>Turn this to On to increase the maximum number of characters that can be printed in a line for an A4 page (78 characters at 10 pitch) and Letter size page (80 characters at 10 pitch). This setting is only effective in PCL6 emulation.</p> <p>Value: [OffOff], [OnOn]</p>

Item	Description
[FormFeed TimeOut]	<p>Receiving print data from the computer, the machine may sometimes wait if there is no information signaling that the last page does not have any more data to be printed. When the preset timeout passes, the machine automatically prints paper. The options are between 5 and 495 seconds.</p> <p>Value: 5 to 495 seconds (in 5 second increments)</p>
[LF Action]	<p>Set the line feed action when the machine receives the line feed code (character code 0AH).</p> <p>Value: [LF Only], [LF and CR], [Ignore LF]</p>
[CR Action]	<p>Set the character return action when the machine receives the character return code (character code 0DH).</p> <p>Value: [CR Only], [LF and CR], [Ignore CR]</p>
[Job Name]	<p>Set whether the job name set in the printer driver is displayed.</p> <p>Value: [OffOff], [OnOn]</p> <hr/> <p> NOTE</p> <p>If you select [On], select from [Job Name], [Job No.+Job Name] or [Job Name+Job No.] to use as the job name.</p> <hr/>
[User Name]	<p>Set whether the user name set in the printer driver is displayed.</p> <p>Value: [Off], [On]</p>
[MP Tray Priority]	<p>If paper is set in the MP Tray then it is possible for priority to be given to that MP tray in the paper feed.</p> <p>Value</p> <p>[OffOff]: The printer driver settings are followed.</p> <p>[Auto Feed]: If Auto is selected in the printer driver and there is paper in the MP tray then the paper feed will be from the MP tray.</p> <p>[Always]: If there is paper in the MP tray then the paper feed will be from the MP tray regardless of what is set in the printer driver.</p>
[Paper Feed Mode]	<p>While printing from the computer, select how to feed paper when the paper source and type are specified.</p> <p>Value</p> <p>[Auto]</p> <p>Search the paper source that matches the selected paper size and type.</p> <p>[Fixed]</p> <p>Print on paper loaded in the specified paper source.</p>

Item	Description
[Auto Cass.Change]	<p>Select the following actions when the paper runs out in the paper source while printing. Value: [OffOff], [OnOn]</p> <hr/> <p> NOTE</p> <p>If you select [OffOff], when the printer runs out of paper, it displays "Load paper in cassette #." (where # is the cassette number) or "Load paper in MP tray." and stops printing. When you load the paper in the cassette displayed in the message, printing resumes. If you wish to print from another cassette, select [Paper]. Select the paper source, and select the [OK] key. When selecting [On], the machine continues printing automatically when the other cassette contains the same paper as the currently-used cassette.</p> <hr/>
[Resolution]	<p>Set the resolution used for printing. Value: [300dpi], [600dpi], [Fine1200], [Fast1200]</p> <hr/> <p> NOTE</p> <p>Settings that are received from the printer driver have priority over the operation panel settings.</p> <hr/>
[KIR]	<p>Select the default KIR (smoothing) setting. Value: [Off], [On]</p>
[Job Terminator]	<p>You can select the condition which is regarded as a job termination if the print job could not be processed until the end due to your environment and the other reason.</p> <p>Value</p> <p>[EOJ] The command recognized as a termination of the job data is regarded as one job until it is detected.</p> <p>[End of Session] The data included in a network session at network connection is regarded as one job.</p> <p>[UEL] The UEL included in the termination of the job data is regarded as one job until it is detected.</p>

[Send]

[System Menu/Counter] key > [▲] [▼] keys > [Send] > [OK] key

[Select Key Set. Folio]

Item	Description
[Select Key Set. Folio]	<p>You can register frequently used sending functions for the selection key. You can easily set it by selecting the selection key.</p> <p>Value: [None], [Color Selection], [Original Size], [Original Image], [Scan Resolution], [Sending Size], [Border Erase], [Zoom], [Orig.Orientation], [Continuous Scan], [File Format], [File Name Entry], [Subject/Body], [JobFinish Notice], [FAX Resolution], [FAX Direct TX], [FAX Delayed TX], [FAX RX Polling], [FAX TX Report], [Density], [Clarify Text], [FTP Encrypted TX], [File Separation][Sharpness], [Contrast], [Backgrnd Density], [Saturation], [Prevent Bleed-t], [Erase Colors], [Skip Blank Page]</p>

[DestinationCheck]

Select whether to display the confirmation screen of destinations.

It also applies when sending faxes.



Item	Description
[Check beforeSend]	<p>Select whether to display the confirmation screen of destinations after pressing the [Start] key when performing sending jobs.</p> <p>Value: [Off], [On]</p>
[Check New Dest.]	<p>When adding new destination, select whether to display the entry check screen to check the entered destination.</p> <p>Value: [Off], [On]</p>



Other Items

Item	Description
[New Dest. Entry]	<p>Value: [Permit], [Prohibit]</p> <p>Select whether to permit direct entry of destination.</p> <p>It also applies when sending faxes.</p>
[Recall Dest.]	<p>Value: [Permit], [Prohibit]</p> <p>Select whether to permit usage of [Redirect] on the Send screen.</p> <p>It also applies when sending faxes.</p>
[Broadcast]	<p>Value: [Permit], [Prohibit]</p> <p>Set whether to enable broadcast.</p>
[Dest.Hist. Usage]	<p>Value: [Permit], [Prohibit]</p> <p>Allow to use the destination history.</p>
[Del.Dest.History]	Delete the destination history.

Item	Description
[Default Screen]	Value: [Destination], [Address Book] Set the default screen displayed when you select the [Send] key.
[Send and Forward]	Value: [Forward], [Destination] [Forward] Value: [Off], [On] [Destination] Value: [Confirmation] > Destination Check, [Register] > [Address Book], [Address Entry] [Address Book] > Address Registration [Address Entry] Value: [E-mail], [Folder(SMB)], [Folder(FTP)]

[DigitalSignature]

Item	Value
[DigitalSignature]	<p>Select whether to add a digital signature.</p> <p>Value:</p> <p>[Off] Does not add a digital signature.</p> <p>[Specify Each Job] Whether to add a digital signature is selected each time of sending.</p> <p>[On] Always adds a digital signature when sending.</p> <hr/> <p> NOTE</p> <p>When [On] is selected, [PDF/A-1b] and [PDF/A-1a] cannot be selected in "PDF/A".</p> <p>➔ PDF/A (page 327)</p> <hr/>
[Format]	<p>Select an algorithm used for encryption of digital signature.</p> <p>Value: [SHA-1], [SHA-256], [SHA-384], [SHA-512]</p> <hr/> <p> NOTE</p> <p>This function is displayed when [DigitalSignature] is set to [Specify Each Job] or [On].</p> <hr/>

Item	Value
[Confirm Password]	<p>Select whether to confirm password when setting digital signature. Value: [Off], [On]</p> <hr/> <p> NOTE</p> <p>This function is displayed when [DigitalSignature] is set to [Specify Each Job].</p> <hr/>
[Password]	<p>Set a password required for setting digital signature. Enter a new security password 6 to 16 alphanumeric characters and symbols.</p> <hr/> <p> NOTE</p> <p>This function is displayed when [DigitalSignature] is set to [Specify Each Job].</p> <hr/>

[E-mail Settings]

Item	Description
[Sender Address]	<p>When the user login is set to ON, login user name, password and E-mail address of login user are used for SMTP authentication and e-mail sender address.</p> <p>Value:</p> <p>[Use Sys. Setting]</p> <p>SMTP sender address information set with Command Center RX is used for SMTP authentication and E-mail sender address information.</p> <p>[Use Login User]</p> <p>Login User information is used for SMTP authentication and E-mail sender address information.</p>

[FAX]

[System Menu/Counter] key > [▲] [▼] keys > [FAX] > [OK] key

Configures settings for fax functions.

For details, refer to the following:

➔ **FAX Operation Guide**

[Document Box]

[System Menu/Counter] key > [▲] [▼] keys > [Document Box] > [OK] key

[Sub Address Box]



→ FAX Operation Guide

[Job Box]

→ FAX Operation Guide

[System Menu/Counter] key > [▲] [▼] keys > [Document Box] > [OK] key > [▲] [▼] keys > [Job Box] > [OK] key

Configure settings for Job Box.

Item	Description
[Quick Copy Jobs]	<p>To maintain free space on the hard disk, you can set the maximum number of stored jobs. Value: number between 0 and 300</p> <hr/> <p> NOTE</p> <p>When [0] is set, Quick Copy cannot be used.</p> <hr/>
[JobRet. Deletion]	<p>This setting specifies that documents, such as Private Printing, Quick Copying, or Proof and Hold Printing, saved temporarily in the job box are automatically deleted after they have been saved for a set time. Value: [Off], [1 hour], [4 hours], [1 day], [1 week]</p> <hr/> <p> NOTE</p> <p>This function is valid for documents saved after the function is set. Regardless of this function setting, temporary documents are deleted when the power switch is turned off.</p> <hr/>

[Polling Box]

→ FAX Operation Guide

[Application]

[System Menu/Counter] key > [▲] [▼] keys > [Application] > [OK] key > [Menu] > [▲] [▼] keys

The functionality of the machine can be expanded by installing applications. Applications that help you perform your daily more efficiently such as a scan feature and an authentication feature are available. For details, contact your sales representative or dealer.

[Edit Destination]

[System Menu/Counter] key > [▲] [▼] keys > [Edit Destination] > [OK] key

[Address Book]

[Edit Destination] > [OK] key > [▲] [▼] keys > [Address Book] > [OK] key

Configure settings for address book.

→ [Adding a Destination \(Address Book\) \(page 161\)](#)

[Edit Restriction]

[System Menu/Counter] key > [▲] [▼] keys > [Edit Destination] > [OK] key > [▲] [▼] keys > [Edit Restriction] > [OK] key

Item	Description
[Address Book]	Restrict editing of the address book. If you select [Admin. Only], you can only edit the Address Book by logging in as administrator. Value: [Off], [Admin. Only]
[One Touch Key]	Restrict editing of the One Touch Key. If you selected [Admin. Only], you can only edit the One Touch Key by logging in with administrator privileges. Value: [Off], [Admin. Only]

[Print List]

[System Menu/Counter] key > [▲] [▼] keys > [Edit Destination] > [OK] key > [▲] [▼] keys > [Print List] > [OK] key

Item	Description
[Addr Book(Index)]	Sets the print content for the Address Book (header). Value: [All], [E-mail], [Folder], [FAX]
[Addr Book(No.)]	Sets the print settings for the address book (number). Value: [All], [E-mail], [Folder], [FAX]
[One Touch]	Sets the print settings for the One-touch list. Value: [All], [E-mail], [Folder], [FAX]

[AddrBookDefaults]

[Edit Destination] > [OK] key > [▲] [▼] keys > [AddrBookDefaults] > [OK] key

NOTE

This function is not displayed if Ext Address Book is not set.

Item	Description
[Address Book]	Configure what type of address book to display. Value: [Machine AddrBook], [Ext Address Book] For information on the Ext Address Book, see the following: ➔ Command Center RX User Guide

[Adjust/Maint.]

Adjust printing quality and conduct machine maintenance.

[System Menu/Counter] key > [▲] [▼] keys > [Adjust/Maint.] > [OK] key

[Copy Denst. Adj.]

Item	Description
[Copy Denst. Adj.]	Makes the overall density of the copy darker or lighter. [-3 Lighter], [-2], [-1], [0 Normal], [+1], [+2], [+3 Darker]

[Send/Box Density]

Item	Description
[Send/Box Density]	Makes the overall reading density darker or lighter when sending or storing the data in Document Box. Value: [-3 Lighter], [-2], [-1], [0 Normal], [+1], [+2], [+3 Darker]

[FAX Denst. Adj.]

Item	Description
[FAX Denst. Adj.]	Make the overall fax reading density darker or lighter. Value: [-3 Lighter], [-2], [-1], [0 Normal], [+1], [+2], [+3 Darker]

[Sharpness Adj.]

Adjusts the sharpness of image outlines.

Item	Description
[Copy]	Makes the outline of the image darker or lighter overall when copying. Value: [-3(Grayish)], [-2], [-1], [0], [1], [2], [3(Vivid)]
[Send/Box]	Darkens or lightens the overall outline of the image when sending it or saving it to the document box. Value: [-3(Grayish)], [-2], [-1], [0], [1], [2], [3(Vivid)]

[Contrast (Copy)]

Item	Description
[Contrast (Copy)]	Increases or decreases the overall contrast of copies. Value: [-3], [-2], [-1], [0], [1], [2], [3]

[Contrast (Send)]

Item	Description
[Contrast (Send)]	Increases or decreases the overall contrast when documents are sent or saved in a document box. Value: [-3], [-2], [-1], [0], [1], [2], [3]

[Backgrnd Density]

Make the overall background darker or lighter.

Item	Description
[Copy(Auto)]	Darkens or lightens overall background density adjustment during copying. Value: [-3 Lighter], [-2], [-1], [0 Normal], [+1], [+2], [+3 Darker]
[Send/Box(Auto)]	Darkens or lightens overall background density when sending images or storing them in the Document Box. Value: [-3 Lighter], [-2], [-1], [0 Normal], [+1], [+2], [+3 Darker]

[EcoPrint]

Select the default Toner Save Level (EcoPrint).

Item	Description
[Save Level(Copy)]	Select the default Toner Save Level (EcoPrint). Value: [5(Higher)], [4], [3], [2], [1(Lower)] Raising the level reduces toner consumption, but image quality falls.
[SaveLvl(Printer)]	Select the default Toner Save Level (EcoPrint). Value: [5(Higher)], [4], [3], [2], [1(Lower)] Raising the level reduces toner consumption, but image quality falls.

[Print Density]

Item	Description
[Print Density]	Make the overall print density darker or lighter. Value: [1 (Lighter)], [2], [3], [4], [5 (Darker)]

[AutoColorCorrect]

Item	Description
[AutoColorCorrect]	This setting allows you to adjust the detection level used by the machine to determine whether the original is color or black and white in Auto Color Selection Mode. Setting a lower value will result in more originals being identified as color, while a larger value will tend to increase the number of originals being identified as black and white. Value: [5], [4], [3], [2], [1]

[Correct. Bk Line]

Item	Description
[Correct. Bk Line]	Correct fine lines (streaks caused by contamination), which may appear on the image, when the document processor is used. Value: [Off], [On(Low)], [On(High)]

[Clarify Text]

Adjust the legibility of characters.

Item	Description
[Level]	Value: [Low], [Middle], [High] Increasing the level will increase the reproduction level of characters.
[Noise Removal]	Select whether to remove noise. [Off], [On]

[Service Setting]

Item	Description
[Service Setting]	Perform the maintenance and inspection of the machine. This menu is primarily used by service personnel for maintenance work.

9 User Authentication and Accounting (User Login, Job Accounting)

Overview of User Login Administration

User login administration specifies how the user access is administered on this machine. Enter a correct login user name and password for user authentication to login.

- 1 Enable User Login Administration
 - ➔ [Enable User Login Administration \(page 484\)](#)
- 2 Set the user
 - ➔ [Setting User Login Administration \(page 485\)](#)
- 3 Enter the login user name and password and execute the job
 - ➔ [Login \(page 63\)](#)

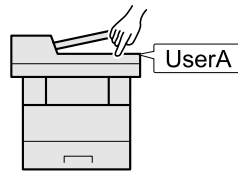

Managing the Job Account from PC

In addition to the above settings, the following are necessary to manage the job account from PC.

To Manage the Users to Print from PCs

Printer driver settings are necessary to manage the users that print on the machine from PCs.

- ➔ [Managing the Users that Print on This Machine from a PC \(page 494\)](#)

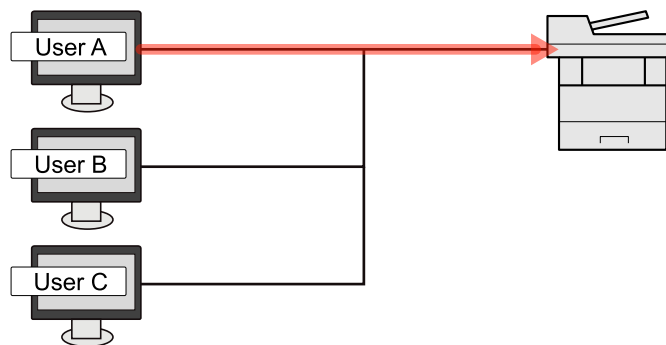

Managing the Users to Use TWAIN for Scanning

TWAIN driver settings on the PC are necessary to manage the users that use TWAIN for scanning.

- ➔ [Managing the Users to Scan Using TWAIN \(page 497\)](#)

Managing the Users to Use WIA for Scanning

WIA driver settings on the PC are necessary to manage the users that use WIA for scanning.

- ➔ [Managing the Users to Scan Using WIA \(page 498\)](#)

Managing the Users that Send Faxes from a PC

FAX driver settings on the PC are necessary to manage the users that send faxes from a PC.

➔ [Managing the Users that Send Faxes from a PC \(page 496\)](#)

The fax function can be used on products equipped with fax capability.

Enable User Login Administration

This enables user login administration.

Select one of the following authentication methods:

Item	Description
[Local Authentic.]	User authentication based on user properties on the local user list stored in the machine.
[Netwk Authentic.]	User authentication based on Authentication Server. Use a user property stored in Authentication Server to access the network authentication login page.

1 Display the screen

- [System Menu/Counter] key > [▲] [▼] keys > [User/Job Account] > [OK] key



NOTE

If the user authentication screen appears, log in with a user who has the privilege to configure this setting. If you do not know your login user name or password, please contact your administrator.

- [▲] [▼] keys > [User Login Set.] > [OK] key

2 Configure the settings

- [▲] [▼] keys > [User Login] > [OK] key > [▲] [▼] keys > [Local Authentic.] or [Netwk Authentic.] > [OK] key
 - Select [Off] to disable user login administration.
 - If [Local Authentic.] is selected, set [Local Authentic.]
 - ➔ [Local Authorization \(page 499\)](#)
 - If [Netwk Authentic.] is selected, set [Server Settings].
 - ➔ [Server Settings \(page 500\)](#)



NOTE

If you cannot login because of the setting of the machine, login with any administrator registered in the local user list and correct the settings.

Setting User Login Administration

This registers, alters and deletes users and configures the settings for User Login Administration.

Authentication Security

If user authentication is enabled, configure the user authentication settings.

User Account Lockout Setting

You can prohibit the use of a user account if an incorrect password is entered repeatedly to login with that account.

1 Display the screen

- 1 [System Menu/Counter] key > [▲] [▼] keys > [User/Job Account] > [OK] key



NOTE

If the user authentication screen appears, log in with a user who has the privilege to configure this setting. If you do not know your login user name or password, please contact your administrator.

- 2 [▲] [▼] keys > [User Login Set.] > [OK] key > [▲] [▼] keys > [Account Lockout] > [OK] key

2 Configure the settings.

Configurable items are as follows:

[Lockout]

Select whether or not account lockout policy is enabled.

Value: [Off], [On]

[Lockout Policy]

Specify the conditions and the extent to which the account lockout is applied.

Value

[Number ofRetries]: Specify how many login retries are allowed until the account is locked out. (1 to 10 times)

[Lockout Duration]: Specify how long the account is to be locked out until it is unlocked. (1 to 60 minutes)

[Lockout Target]: Specify the extent to which the account lockout is applied. Select from [Remote Only] and [All]. Remote Login Only locks out all operations from outside the operation panel.

[Locked out Users]

Displays a list of locked out users. You can unlock a user by selecting the user in the list, and selecting [Unlock].



NOTE

This function is displayed when account lockout policy is enabled.

Password Policy Settings

You can prohibit the setting and use of passwords that do not comply with the password policy. Setting the Password Policy makes it more difficult to break the password.

1 Display the screen

- 1 [System Menu/Counter] key > [▲] [▼] keys > [User/Job Account] > [OK] key



NOTE

If the user authentication screen appears, log in with a user who has the privilege to configure this setting. If you do not know your login user name or password, please contact your administrator.

- 2 [▲] [▼] keys > [User Login Set.] > [OK] key > [▲] [▼] keys > [Password Policy] > [OK] key

2 Configure the settings.

Configurable items are as follows:

[Password Policy]

Select whether or not password policy is enabled.

Value: [Off], [On]

[Min. PW Length]

Set the minimum password length of characters for password.

Value: [Off], [On] (1 to 64 characters)

[PW Complexity]

Set the password complexity.

Value

[Reject common PW]:Off, On

[Include uc ltr.]:Off, On

[Include lc ltr.]:Off, On

[Include number]:Off, On

[Include symbol]:Off, On

[Maximum PW Age]

Set the maximum password age.

Value: [Off], [On] (1 to 180 days)

[Violator List]

List of users who do not meet password policy requirements.

Adding a User (Local User List)

You can add 100 user (including the default login user name).

1 Display the screen

- 1 [System Menu/Counter] key > [▲] [▼] keys > [User/]Job Account] > [OK] key



NOTE

If the user authentication screen appears, log in with a user who has the privilege to configure this setting. If you do not know your login user name or password, please contact your administrator.

- 2 [▲] [▼] keys > [User Login] > [OK] key [▲] [▼] keys > [Local User List] > [OK] key > [Menu] key > [▲] [▼] keys > [User Login] > [OK] key

2 Enter the user information.

- 1 Enter the name to be displayed on the user list (up to 32 characters) and press the [OK] key.
- 2 Enter the reading (up to 32 characters) of the user name, and then enter the key [OK].



NOTE

For details on entering characters, refer to the following:

➔ [Character Entry \(page 761\)](#)

- 3 Enter the login username (up to 64 characters) that you enter when logging in, and select the key [OK].



NOTE

The same login user name cannot be registered.

- 4 To enter detailed user information, press the [▲] [▼] keys > [Detail] > [OK] key
- 5 To end the operation, press the [▲] [▼] keys > [Exit] > [OK] key
- 6 Enter the user information details. Select [Edit] [Change] or [Detail] for each item, enter the details, then select the [OK] key.

Select the [▶] key to display the next page.

Select the [◀] key to return to the previous page.

The following items can be set.

User Name

Enter the name displayed on the user list (up to 32 characters).

Furigana

Enter the reading of the user name up to 32 characters.

Login User Name

Enter the login user name to login (up to 64 characters). The same login user name cannot be registered.

Login Password

Enter the password to login (up to 64 characters).

E-mail Address

The user can register his/her E-mail address. Register if you wish to use E-mail sending. The registered address will be automatically selected for subsequent operations that need any E-mail function.

Access Level

Select [Administrator] or [User] for user access privileges.

Permit SysAdmin

If the user privileges level set in Access Level is [User], select the items for which the user has setting privileges from the following:

- Paper
- Address Book
- User/Job Account
- Basic Network
- Basic Device
- Dev/Net Application Settings

Account Name

Add an account where the user belongs. The user, who registered his/her account name, can login without entering the account ID.

➔ [Overview of Job Accounting \(page 515\)](#)

Cloud User Name

This is displayed when the cloud integration function is being used.

ID Card Info.

Register ID card information. Place the ID card on the ID card reader.



NOTE

This function is displayed when the optional ID Card Authentication Kit is activated.

➔ [Option configuration \(page 756\)](#)

Local Authoriz.

Set usage authority for each user.

Print Restrict.

Select whether or not use of the print function of the printer is prohibited. Applicable print functions are as follows:

Value: [Off], [Reject Usage]

- Print from USB Drive
- Print Report
- Print from PC

Select whether or not use of the copy print function is prohibited.

Value: [Off] , [Reject Usage]

Duplex Restrict.

Select whether only duplex printing is allowed.

Value: [Off], [2-sided Only]

CombineRestrict.

Specify whether only Combine is allowed.

Value: [Off], [2in1 & 4in1 Only], [4in1 Only]

EcoPrint Restr.

Specify whether only EcoPrint is allowed.

Value: [Off], [EcoPrint Only]

Send Restrict.

Select whether or not use of the send function is prohibited.

Value: [Off], [Reject Usage]

FAX Restrict.

Select whether or not use of the fax send function is prohibited.

Displays only for fax models.

Value: [Off], [Reject Usage]

Storing in Box

Select whether or not to reject usage of storing in the document boxes.

Value: [Off], [Reject Usage]

StoringIn USBDrv

Set whether or not to reject usage of storing in the USB drive.

Value: [Off], [Reject Usage]

*1 Be sure to enter the items.

*2 Displayed when Local Authorization is enabled.

➔ [Local Authorization \(page 499\)](#)



NOTE

- For details on entering characters, refer to the following:
➔ [Character Entry \(page 761\)](#)
 - If you selected or [Fax] in the Default Screen for My Panel, select , , or [External Address Book] as the screen to display.
-

3 Select the [OK] key.

A new user is added on the local user list.

Change the user properties

Types of user properties that could be changed may be different depending on user access privilege.

1 Display the screen

- 1 [System Menu/Counter] key > [▲] [▼] keys > [User/Job Account] > [OK] key > [User Login Set.] > [OK] key > [▲] [▼] keys > [Local User List] > [OK] key



NOTE

If the user authentication screen appears, log in with a user who has the privilege to configure this setting. If you do not know your login user name or password, please contact your administrator.

2 Change the user properties

- 1 Select the user whose properties you wish to change.
[Menu] > [▲] [▼] keys > [Detail/Edit] > [OK] key



IMPORTANT

Users with permissions [User] can register and modify user information only when [User/Job Account] is enabled in [Permit SysAdmin].

- 2 Configure the settings.
 - User Name
 - Login User Name^{*1}
 - Login Password
 - E-mail Address
 - Access Level^{*1}
 - Permit SysAdmin^{*1}
 - Account Name
 - Cloud User Name
 - ID Card Info. ^{*2}
 - Authoriz. RulesLocal Authoriz. ^{*3}
 - My Panel

- Domain name^{*4}

*1 You can change only when you log in with machine administrator authority.

*2 Displayed when the optional IC Card Authentication Kit is activated.

➔ [Overview of the Applications \(page 759\)](#)

*3 Displayed when Local Authorization is enabled.

➔ [Local Authorization \(page 499\)](#)

For details on each item, refer to step 3 of "Adding a User (Local User List)" to change a user property.

➔ [Adding a User \(Local User List\) \(page 487\)](#)

*4 If the user is a network user with local user privileges, the Domain Name is displayed.

➔ [Configure Network User Rights \(page 501\)](#)

3 Select the [Register] key.

The user information is changed.

Deleting a user.

1 Display the screen

- 1 [System Menu/Counter] key > [▲] [▼] keys > [User/Job Account] > [OK] key > [▲] [▼] keys > [User Login Set.] > [OK] key > [▲] [▼] keys > [Local User List] > [OK] key



NOTE

If the user authentication screen appears, log in with a user who has the privilege to configure this setting. If you do not know your login user name or password, please contact your administrator.

2 Deleting a user.

- 1 Select the user to delete.
- 2 [Menu] > [▲] [▼] keys > [Delete] > [OK] key
- 3 Select [Yes].
The selected user will be deleted.



NOTE

The default user with machine administrator rights cannot be deleted.

➔ [Administrator Privileges Overview \(page 108\)](#)

Managing the Users that Print on This Machine from a PC

To manage the users that print on this machine from a PC, the following settings are necessary in the printer driver. Instructions are based on interface elements as they appear in Windows 10.

1 Display the screen

- 1 Select the Windows [Start] button → [Windows System] → [Control Panel] → [Devices and Printers].



NOTE

For Windows 11, select the Windows [Start] button → [All apps] → [Windows Tools] → [Control Panel] → [Devices and Printers], in that order.

- 2 Right-click the printer driver icon of the machine, and click the [Printer Properties] menu of the printer driver.
- 3 Click [Administrator Settings] in the [Device Settings] tab.

2 Configure the settings

- 1 Select [User login] in the [User login] tab.

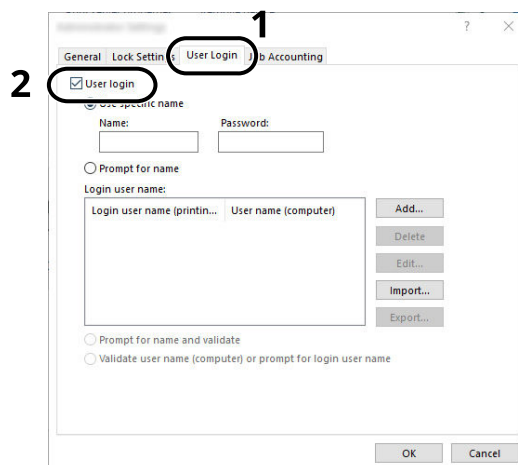

- 2 Set the User Login Administration.

[Use specific Login User Name]

This option can be used to specify a user name and password to use the same User login for every print job. If this option is selected, the user does not have to type the name and password for each print job.

[Prompt for name]

A screen for entering the user name and password will be displayed when attempting a printing. The user name and password must be entered each time a printing is attempted.

[Prompt for name and validate]

A screen for entering the user name and password will be displayed when attempting a printing. The user name and password stored in the "Login user name" needs to be entered. The user name and password must be entered each time a printing is attempted.

[Validate user name (computer) or prompt for login user name]

When printing, the Windows user name is searched in the "Login user names list" and printing is possible if the name is registered. If the name is not registered, the printing will be canceled for users with only user authority. If the user has administrator privileges, the screen to enter the user name and password will appear.

- 3 Click [OK].



NOTE

For other settings of job accounting, refer to the following:

➔ **Printer Driver User Guide**

Managing the Users that Send Faxes from a PC

To manage the users that send faxes from a PC, the following settings are necessary in the FAX driver. Instructions are based on interface elements as they appear in Windows 10.

1 Display the screen

- 1 Select the Windows [Start] button → [Windows Tools] → [Control Panel] → [Devices and Printers].

NOTE

For Windows 11, select the Windows [Start] button → [All apps] → [Windows Tools] → [Control Panel] → [Devices and Printers], in that order.

- 2 Right-click the Fax Driver icon of the machine, and then click the [Printing preferences] menu.
- 3 Click [FAX TX Setting] in the [Printing Preferences] tab.

2 Configure the settings

- 1 Select [User Login] in the [Authentication] tab.

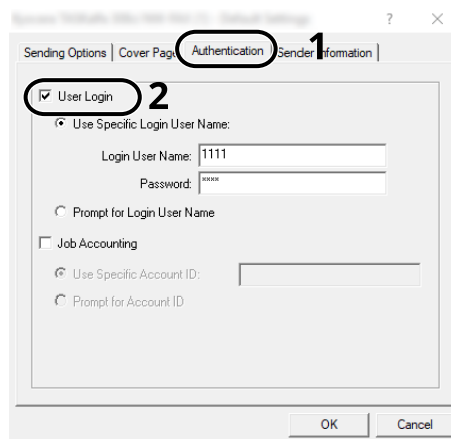

- 2 Set the User Login Administration.

[Use Specific Login User Name]

This option can be used to specify a user name and password to use the same User login for every FAX job. If this option is selected, the user does not have to type the name and password for each FAX job.

[Prompt for Login User Name]

A screen for entering the user name and password will be displayed when attempting a transmission. The user name and password must be entered each time a transmission is attempted.

- 3 Click [OK].

Managing the Users to Scan Using TWAIN

The following TWAIN driver settings are necessary to manage the users that use TWAIN for scanning. Instructions are based on interface elements as they appear in Windows 10.

1 Display the screen

- 1 Click the search box in the taskbar, and enter [TWAIN Driver Setting]. Select [TWAIN Driver Setting] in the search list. Displays the TWAIN Driver Settings screen.
- 2 Select the machine, and click [Edit].

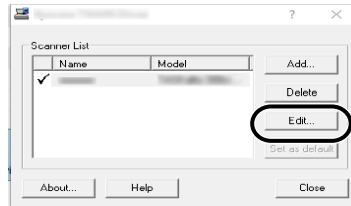

2 Configure the settings

- 1 Click [User Authentication Setting].
- 2 Select [Authentication], and enter Login User Name and Password.



- 3 Click [OK].

Managing the Users to Scan Using WIA

The following WIA driver settings are necessary to manage the users that use WIA for scanning. Instructions are based on interface elements as they appear in Windows 10.

1 Display the screen

- 1 Please select the Windows [Start] button → [Windows Tools] → [Control Panel]. Enter "Scanner" into the search field on the control panel. Select [View scanners and Cameras] in the search list, then the Scanners and Cameras screen appears.

NOTE

- For Windows 11, select the Windows [Start] button → [All apps] → [Windows Tools] → [Control Panel], in that order. Enter "Scanner" into the search field on the control panel. Select [View scanners and cameras] in the search list then the Scanners and Cameras screen appears.

- 2 Select the same name as this machine from WIA Drivers, and click the [Properties] button.

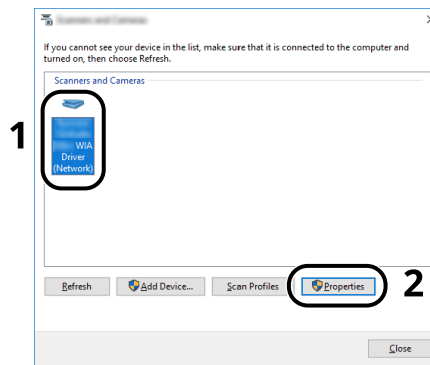

2 Configure the settings

- 1 Select [Authentication] on the [Settings] tab, and enter Login User Name and Password.

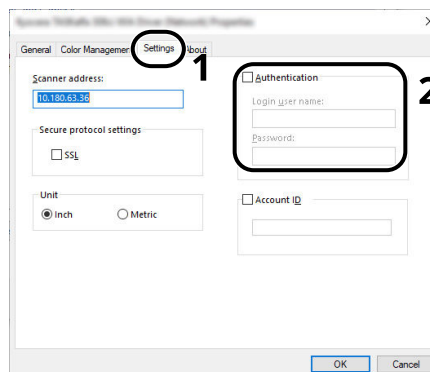

- 2 Click [OK].

Local Authorization

Select whether or not to use Local Authorization.

NOTE

When using Local Authorization, the user authentication type must be set to [Local Authentic.].

→ [Enable User Login Administration \(page 484\)](#)

1 Display the screen

- 1 [System Menu/Counter] key > [▲] [▼] keys > [User/]Job Account] > [OK] key
-

NOTE

If the user authentication screen appears, log in with a user who has the privilege to configure this setting. If you do not know your login user name or password, please contact your administrator.

- 2 [▲] [▼] keys > [User Login Set.] > [OK] key [▲] [▼] keys > [Local Authentic.] > [OK] key

2 Configure the settings

- 1 [▲] [▼] keys > Select [On] or [Off]

Server Settings

Set the server type when network authentication is enabled.

1 Display the screen

- 1 [System Menu/Counter] key > [▲] [▼] keys > [User/Job Account] > [OK] key



NOTE

If the user authentication screen appears, log in with a user who has the privilege to configure this setting. If you do not know your login user name or password, please contact your administrator.

- 2 [Menu] key > [▲] [▼] keys > [User Login Set.] > [OK] key > [User Login] > [OK] key > [Netwk Authentic.] > [OK] key > [▲] [▼] keys > [Server Type] > [OK] key

2 Configure the settings

- 1 Select , or as the and select the [OK] key.

When or is selected, you can configure multiple authentication servers.

Select [Use default host] or [for each domain].

- 2 Enter the host name (64 characters or less) for the Authentication Server, and select the [OK] key. When selecting [Ext.] as the server type, enter the port number.

- 3 Enter the domain name for the Authentication Server, and select the [OK] key.

If domain name is not set, select [-----] and select [Menu]. Select [Edit], select the [OK] key, and enter the domain name (up to 256 characters). Select the [OK] key to register the Default Domain Name. To edit or delete the registered domain, select the registered domain name, and then select [Menu].



NOTE

- Up to 10 domain names can be registered.
 - If the login user name and password are rejected, check the following settings.
 - 1 Network Authentication setting of the machine
 - 2 User property of the Authentication Server
 - 3 Date and time setting of the machine and the Authentication Server
-

Configure Network User Rights

Select whether or not to grant local user rights to network users. If this setting is applied, when a network user logs in, the logged in network user's information is registered as a local user. By setting the account name on the registered local user information, network users can coordinate with job accounting. Displays the "Domain Name" in the user information for local users with rights.

NOTE

- This setting is valid when the server type is [NTLM] .
- For local user information, refer to the following:

→ [Adding a User \(Local User List\) \(page 487\)](#)

1 Display the screen

- 1 [System Menu/Counter] key > [▲] [▼] keys > [User/Job Account] > [OK] key

NOTE

If the user authentication screen appears, log in with a user who has the privilege to configure this setting. If you do not know your login user name or password, please contact your administrator.

- 2 [▲] [▼] keys > [User Login] > [OK] key > [▲] [▼] keys > [NW User Auth.] > [OK] key

2 Configure the settings

Set [Give Authority] to [On] to configure the settings.

Select the [▶] key to display the next page. Select the [◀] key to return to the previous page.

[User Full Action]

Configure the action when the number of users is exceeded when granting local user rights.

Value: [Do Not Add New], [Delete Old User]

Set the expiration date for local user rights that have been granted and that do not require network authentication.

Value: [Always Enabled], [Enabled Period]

Select [Period selection], [Enabled Period] or [Period]the period. (1 to 180 days)

[Local Auth. Def.]

Set the default local user rights that are granted.

Group Authorization Settings

Set restrictions of the machine usage by each individual group registered in the authentication server.

NOTE

To use the group authorization settings, "User Login Set." must be selected for the authentication method in [Netwk Authentic.]. In addition, set "ProtocolSettings" to On in "LDAP".

→ [Enable User Login Administration \(page 484\)](#)

→ [\[ProtocolSettings\] \(page 394\)](#)

Settings to enable group authorization are made on the operation panel. Groups must be registered in Command Center RX.

→ [Command Center RX User Guide](#)

Group Authorization

1 Display the screen

- 1 [System Menu/Counter] key > [▲] [▼] keys > [User/Job Account] > [OK] key

NOTE

If the user authentication screen appears, log in with a user who has the privilege to configure this setting. If you do not know your login user name or password, please contact your administrator.

- 2 [▲] [▼] keys > [User Login Set.] > [OK] key

2 Configure the settings

- 1 [▲] [▼] keys > [Group Auth.] > [OK] key > [▲] [▼] keys > [Off] or [On] > [OK] key

Guest Authorization Settings

When User Login Administration is enabled, set the functions that guest users who cannot log in to the machine are allowed to use.

NOTE

To use Guest Authorization, must be enabled in .
→ [Enable User Login Administration \(page 484\)](#)

Enabling Guest Authorization

1 Display the screen

- 1 [System Menu/Counter] key > [▲] [▼] keys > [User/Job Account] > [OK] key
-

NOTE

If the user authentication screen appears, log in with a user who has the privilege to configure this setting. If you do not know your login user name or password, please contact your administrator.

- 2 [▲] [▼] keys > [User Login Set.] > [OK] key

2 Configure the settings

- 1 [▲] [▼] keys > [Guest Auth.] > [OK] key > [▲] [▼] keys > [Off] or [On] > [OK] key
-

NOTE

- If the guest authorization setting is enabled, the [Logout] must be selected when logging in.
 - In the guest user default settings, only monochrome copying can be used. If you wish to use a different function, log in as a user who can use that function, or change the settings in the guest properties.
-

Configuring Guest Property

Register guest user information and functions that are restricted.

1 Display the screen

- 1 [System Menu/Counter] key > [▲] [▼] keys > [User/Job Account] > [OK] key



NOTE

If the user authentication screen appears, log in with a user who has the privilege to configure this setting. If you do not know your login user name or password, please contact your administrator.

- 2 [▲] [▼] keys > [User/Job Account] > [OK] key

2 Configure the settings

- 1 [▲] [▼] keys > [Guest Auth. Set.] > [OK] key > [▲] [▼] keys > [Guest Property] > [OK] key

- 2 Register guest user information and functions that are restricted.

Select [Edit], [Change] or [Detail] for each item, enter the details, then select the [OK] key.

Select the [▶] key to display the next page. Select the [◀] key to return to the previous page.

User Name

Enter the name displayed on the user list (up to 32 characters). The default setting is "Guest User".

Access Level

The authority of the user appears. This cannot be changed.

Account Name

Add an account where the user belongs.

If the user does not belong to any account, select .

Authoriz. Rules

Set usage authority for each user.

The items you can restrict the access level with are as follows.

Print Restrict.

Select whether or not use of the print function of the printer is prohibited.

Applicable print functions are as follows:

- Print from USB Drive

Copy Restrict.

Select whether or not to prohibit use of copy print functions.

Duplex Restrict.

Select whether only duplex printing is allowed.

CombineRestrict.

Specify whether only Combine is allowed.

EcoPrint Restr.

Specify whether only EcoPrint is allowed.

Send Restrict.

Select whether or not use of the send function is prohibited.

FAX Restrict.

Select whether or not use of the fax send function is prohibited.

Displays only for fax models.

StoringIn USBDrv

Set whether or not to reject usage of storing in the USB drive.

3 Register the user.

- 1 Select the [OK] key.

Obtain NW User Property

Set the required information to obtain the network user property from the LDAP server.

NOTE

- To obtain the network user property from the LDAP server, [Netwk Authentic.] must be selected for the user authentication method in "User Login Set.". In addition, set "ProtocolSettings" to On in [LDAP].
- The settings for obtaining network user property are configured on the operation panel. Further details on the information to be obtained can be set in Command Center RX.

➔ **Command Center RX User Guide**

➔ [Enable User Login Administration \(page 484\)](#)

➔ [\[ProtocolSettings\] \(page 394\)](#)

1 Display the screen

- 1 [System Menu/Counter] key > [▲] [▼] keys > [User/Job Account] > [OK] key
-

NOTE

If the user authentication screen appears, log in with a user who has the privilege to configure this setting. If you do not know your login user name or password, please contact your administrator.

- 2 [▲] [▼] keys > [User Login Set.] > [OK] key

2 Configure the settings

- [▲] [▼] keys > [NW User Property] > [OK] key > [▲] [▼] keys > [Off] or [On] > [OK] key

IC Card Authentication Kit Settings

The IC card authentication kit allows user authentication using an IC card.

IMPORTANT

The deployment procedure requires a license key. The license key is issued when the "machine number" of the machine and the "product ID" written on the license certificate of this product are registered on the website specified by the distributor.

For instructions on how to read an IC card, refer to the instructions included with the card reader. In order to perform the local authentication with IC card, IC card information has to be registered to the local user list in advance.

To use an IC card for network authentication, you must install KYOCERA Net Manager on the network authentication server. Register a user from the server and enter the ID number of the IC card. For details, refer to KYOCERA Net Manager Install Manual.

CAUTION

This product is an inductive read/write communication equipment which has received the type designation from the Minister for Internal Affairs and Communications based on the Radio Law. Do not use in areas where radio wave usage is restricted. People with implantable medical devices (such as cardiac pacemakers) should use this device at a distance of at least 22 cm from the implanted site. (In general, studies have shown that wireless card "contactless IC card" systems and RFID "electronic tag" devices may have an effect on implantable medical devices.) For details, please visit the Ministry of Internal Affairs and Communications website.

Enabling the IC Card Authentication Kit

To perform user authentication using an IC card, you must enable the IC Card Authentication Kit.

➔ [Starting Application Use \(page 759\)](#)

Set the user login administration

If you enable user login administration on the machine itself, you must set up user login administration for the printer driver in order to print from the computer.

➔ **Printer Driver User Guide**

➔ [Managing the Job Account from PC \(page 482\)](#)

Register ID card information.

To log in by ID card, register your IC card information in user information.

NOTE

If the user authentication is displayed, refer to the login or keyboard login procedure and log in using an IC card or login user name registered with administrator authority.

- 1 [System Menu/Counter] key > [▲] [▼] keys > [User/Job Account] > [OK] key < [▲] [▼] keys > [User Login Set.] > [▲] [▼] keys > [Local User List] > [OK] key
- 2 [▲] [▼] keys > Select the user to register the IC card information > [OK] key
- 3 [◀] [▶] keys > [ID Card Info] > [Change] > [Read] > [OK] key
- 4 Hold the IC card you want to register over the card reader and select [Read]. If "Completed. " is displayed, select [Close].



NOTE

Depending on the card reader, [Read] may not be displayed.

5 Select [Yes]

The user information is changed, "Registered. " is displayed and the IC card information is deleted.

Delete the ID card information

Register ID card information from the user information.

NOTE

If the user authentication is displayed, refer to the login or keyboard login procedure and log in using an ID card or login user name registered with administrator authority.

- 1** [System Menu/Counter] key > [▲] [▼] keys > [User/Job Account] > [OK] key < [▲] [▼] keys > [User Login Set.] > [▲] [▼] keys > [Local User List] > [OK] key
- 2** [▲] [▼] keys > Select the user to register the ID card information > [OK] key
- 3** [◀] [▶] keys > [ID Card Info] > [Change] > [Delete] > [OK] key
- 4** Select [Yes]

The user information is changed, "Registered. " is displayed and the ID card information is deleted.

ID Card Settings

If ID card authentication is enabled, select the authentication type.

NOTE

This functions appears when the Card Authentication kit is activated.

→ [Option configuration \(page 756\)](#)

Key Login

When ID card authentication is enabled, select whether or not login by keyboard is allowed.

1 Display the screen

- 1 [System Menu/Counter] key > [▲] [▼] keys > [User/Job Account] > [OK] key > [User Login Set.] > [OK] key [▲] [▼] keys > [ID Card Settings] > [OK] key

NOTE

If the user authentication screen appears, log in with a user who has the privilege to configure this setting. If you do not know your login user name or password, please contact your administrator.

- 2 [Menu] key > [▲] [▼] keys > [Key Login] > [OK] key

2 Configure the settings

- 1 Select [Permit] or [Prohibit].

Additional Authentication

Select whether or not to require password entry after authenticating by ID card.

NOTE

This function is displayed when "User Login" is enabled.

1 Display the screen

- 1 [System Menu/Counter] key > [▲] [▼] keys > [User/Job Account] > [OK] key > [▲] [▼] keys > [User Login Set.] > [OK] key > [▲] [▼] keys [ID Card Settings] > [OK] key
-

NOTE

If the user authentication screen appears, log in with a user who has the privilege to configure this setting. If you do not know your login user name or password, please contact your administrator.

- 2 [▲] [▼] keys > [Additional Auth.] > [OK] key

2 Configure the settings

- 1 Select [Off], [Use Password], or .
-

NOTE

is displayed only when using PIN Code Authorization.

➔ [PIN Login \(page 513\)](#)

Simple Job Printing

Displays a list of print jobs saved to the Stored Job Box when logging in with an IC card via user login.

NOTE

For details on Simple Job Printing, refer to the following:

→ [Simple Job Printing \(page 197\)](#)

1 Display the screen

- 1 [System Menu/Counter] key > [▲] [▼] keys > [User/Job Account] > [OK] key > [▲] [▼] keys > [User Login Set.] > [OK] key
-

NOTE

If the user authentication screen appears, log in with a user who has the privilege to configure this setting. If you do not know your login user name or password, please contact your administrator.

- 2 [▲] [▼] keys > [QuickJobPrinting] > [OK] key

2 Configure the settings

Set "DispListOnLogin"[On] to configure the settings.

[LogoutAfterPrint]

Select whether or not to automatically log out after printing.

[Skip PIN&Copies]

Select whether or not to skip entering the PIN code and confirming the number of copies when printing when a PIN code is set.

PIN Login

NOTE

When using PIN Code Authorization, the network authentication must be enabled and must be selected for server type.

→ [Enable User Login Administration \(page 484\)](#)

→ [Server Settings \(page 500\)](#)

1 Display the screen

- 1 [System Menu/Counter] key > [▲] [▼] keys > [User/Job Account] > [OK] key > [▲] [▼] keys > [User Login Set.] > [OK] key

NOTE

If the user authentication screen appears, log in with a user who has the privilege to configure this setting. If you do not know your login user name or password, please contact your administrator.

- 2 [▲] [▼] keys [PIN Login] > [OK] key

2 Configure the settings

- 1 Select [Off] or [On].

Using User Login Administration

This section explains procedures while setting job accounting.

Login/Logout

If user login administration is enabled, the login user name and login password entry screen appears each time you use this machine. Use the procedure below to login and logout.

Login

If the login user name entry screen appears during operations, log in by referring to the following:

➔ [Login \(page 63\)](#)

Logout

When the operation is complete, select the [Logout] key. You will return to the login user name/login password entry screen.

Overview of Job Accounting

Job accounting manages the print count accumulated by individual accounts by assigning an ID to each account.

- 1 Enable job accounting
 - ➔ [Enable job accounting \(page 517\)](#)
- 2 Setting an account.
 - ➔ [Set the Job Accounting\(Local\) \(page 519\)](#)
- 3 Enter the assigned account ID when performing the job.
 - ➔ [Login \(page 533\)](#)
- 4 Count the number of pages printed.

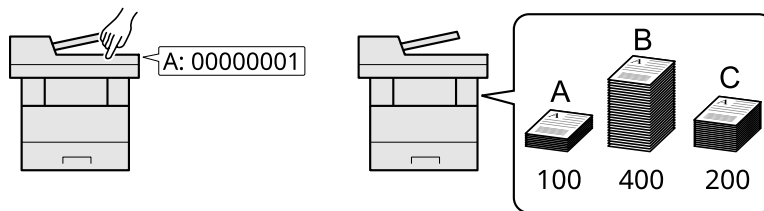

To Manage the Number of Sheets Used on Jobs Printed from a PC

To manage the number of jobs to be printed from the PC on the network, you need to configure settings by using the printer driver on the PC.

- 1 Set Job Accounting for the PC on the network by using the printer driver.
 - ➔ [Job Accounting for Printing \(page 523\)](#)
- 2 Execute printing.
- 3 Count the number of pages printed.

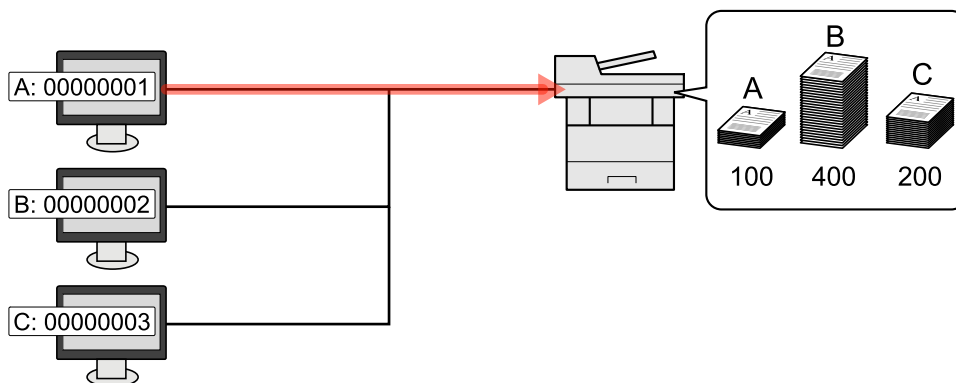

Managing the Scan Job Account by Using TWAIN

To manage the scan job account by using TWAIN, you need to configure the TWAIN driver settings on the computer connected to the machine.

- ➔ [Job Accounting for Scan Using TWAIN \(page 525\)](#)

Managing the Scan Job Account by Using WIA

To manage the scan job account by using WIA, you need to configure the WIA driver settings on the computer connected to the machine.

➔ [Job Accounting for Scan Using WIA \(page 526\)](#)

Managing the FAX Jobs Transmitted from a PC

To manage the number of FAX jobs transmitted from the PC, you need to configure the settings by using the FAX Driver on the PC.

➔ [Job Accounting for the FAX Transmitted from a Computer \(page 527\)](#)

Fax function is available for fax models.

Enable job accounting

1 Display the screen

- 1 [System Menu/Counter] key > [▲] [▼] keys > [User/Job Account] > [OK] key



NOTE

If the user authentication screen appears, log in with a user who has the privilege to configure this setting. If you do not know your login user name or password, please contact your administrator.

- 2 [▲] [▼] keys > [Job Account.Set.] > [OK] key > [▲] [▼] keys [Job Accounting] > [OK] key

2 Configure the settings

Select [On] to enable job accounting.



NOTE

When the display returns to System Menu default screen, logout is automatically executed and the screen to enter the Account ID appears. To continue the operation, enter the Account ID.

Job Accounting

Set the Job Accounting method.

1 Display the screen

- 1 [System Menu/Counter] key > [▲] [▼] keys > [User/Job Account] > [OK] key



NOTE

If the user authentication screen appears, log in with a user who has the privilege to configure this setting. If you do not know your login user name or password, please contact your administrator.

- 2 [▲] [▼] keys > [Job Account.Set.] > [OK] key > [▲] [▼] keys > [AccountingAccess] > [OK] key

2 Configure the settings

- 1 Select [Local], or [Network].

Set the Job Accounting(Local)

You can add, change and delete an account and set the restriction for each account.

Adding an Account

Up to 100100 individual accounts can be added.

1 Display the screen

- 1 [System Menu/Counter] key > [▲] [▼] keys > [User/Job Account] > [OK] key



NOTE

If the user authentication screen appears, log in with a user who has the privilege to configure this setting. If you do not know your login user name or password, please contact your administrator.

- 2 [▲] [▼] keys > [Job Account.Set.] > [OK] key [▲] [▼] keys > [Account. List] > [OK] key

2 Add an account.

- 1 [Menu] key > [▲] [▼] keys > [Add Account] > [OK] key

Account Name

Enter the account name (up to 32 characters).

Account ID

Enter the account ID as many as eight digits (between 0 and 99999999).



NOTE

Any [Account ID] that has already registered cannot be used. Enter any other account ID.

- 2 To apply usage authority, press the [▲] [▼] keys > [Detail] > [OK] key, to end operation, press the [▲] [▼] keys > [Exit] > [OK] key
- 3 Check Account Name and Account ID to set usage authority. To change a setting, select [Edit], enter the details, and select the [OK] key. Select the [▶] key to display the next page. Select the [◀] key to return to the previous page.
➔ [Restricting the Use of the Machine \(page 520\)](#)
- 4 Select the [OK] key.
A new account is added on the Account List.

Restricting the Use of the Machine

This section explains how to restrict the use of the machine by account or the number of sheets available.

Usage Restriction Items

"Copy/Printer Count Method" is "Individual"

Item	Description
[Print Restrict.]	Limits the number of sheets used for copying.
[Print Restrict.]	Limits the number of sheets used for printing.
[Scan Restrict.]	Limits the number of sheets scanned (excludes copying).
[FAX Restrict.]	Limits the number of sheets sent by fax.

"Copy/Printer Count Method" is "Total"

Item	Description
[Print Restrict.]	Limits the total number of sheets used for copying and printing.
[Scan Restrict.]	Limits the number of sheets scanned (excludes copying).
[FAX Restrict.]	Limits the number of sheets sent by fax.

Applying Usage Restriction

Usage restriction can be applied in the following modes:

Item	Description
[Off]	No restriction is applied.
[Counter Limit]	Restricts the print counter in one-page increments up to 9,999,999 copies. If you select [Counter Limit], the [Limit Pages] screen will be displayed after you select the [OK] key. Select the numeric keypad, enter the limit number of pages, and select the [OK] key.
[Reject Usage]	Restriction is applied.

Editing an Account

1 Display the screen

- 1 [System Menu/Counter] key > [▲] [▼] keys > [User/Job Account] > [OK] key



NOTE

If the user authentication screen appears, log in with a user who has the privilege to configure this setting. If you do not know your login user name or password, please contact your administrator.

- 2 [▲] [▼] keys > [Job Account.Set.] > [OK] key [▲] [▼] keys > [Account. List] > [OK] key

2 Edit an account

- 1 Select the account you want to change account information for and select the [OK].
- 2 [▲] [▼] keys > [Detail/Edit] > [OK] key
- 3 Select the item you wish to change, and select the [Edit] key.
Move items using the [▶][◀] keys.



NOTE

Change account information by referring to procedure 2 for followngs.

- ➔ [Adding an Account \(page 519\)](#)
 - ➔ [Restricting the Use of the Machine \(page 520\)](#)
-

- 4 Select the [OK] key.
The account information is changed.

Deleting an Account

1 Display the screen

2 Display the screen

- 1 [System Menu/Counter] key > [▲] [▼] keys > [User/Job Account] > [OK] key



NOTE

If the user authentication screen appears, log in with a user who has the privilege to configure this setting. If you do not know your login user name or password, please contact your administrator.

- 2 [▲] [▼] keys > [Job Account.Set.] > [OK] key [▲] [▼] keys > [Account. List] > [OK] key

3 Deleting

- 1 Select the account to delete and select [Menu].
- 2 [▲] [▼] keys > [Delete] > [OK] key > [Yes]

The account is deleted.

Job Accounting for Printing

To manage the number of pages used for jobs to be printed from the PC, you need to configure the following settings by using the printer driver. Instructions are based on interface elements as they appear in Windows 10.

1 Display the screen

- 1 Select the Windows [Start] button → [Windows Tools] → [Control Panel] → [Devices and Printers].

NOTE

For Windows 11, select the Windows [Start] button → [All apps] → [Windows Tools] → [Control Panel] → [Devices and Printers], in that order.

- 2 Right-click the printer driver icon of the machine, and click the [Printer Properties] menu of the printer driver.
- 3 Click [Administrator] in the [Device Settings] tab.

2 Configure the settings

- 1 Select [Job Accounting] in the [Job Accounting] tab.

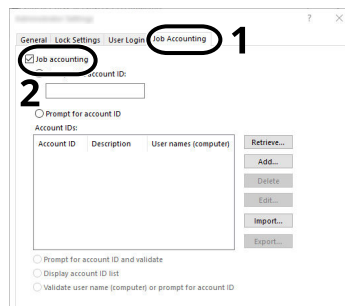

- 2 Set the Job Accounting.

[Use Specific Account ID]

Enter the Account ID. Printing will be performed using the entered Account ID. If this option is selected, the user does not have to enter the Account ID for each print job.

[Prompt for account ID]

A screen for entering the Account ID will be displayed when attempting a printing. The Account ID must be entered each time a printing is attempted.

[Prompt for account ID and validate]

A screen for entering the Account ID will be displayed when attempting a printing. The Account ID stored in the Account ID list needs to be entered. The Account ID must be entered each time a printing is attempted.

[Display account ID list]

The Account ID list is displayed when printing. The Account ID to be used needs to be selected from the list.

[Validate user name (computer) or prompt for account ID]

When printing, the Windows user name is searched in the "Account IDs" and printing is possible if the name is registered. If the Account ID is not registered, the screen for entering the Account ID will appear.

- 3 Click [OK].



NOTE

For other settings of job accounting, refer to the following:

➔ **Printer Driver User Guide**

Job Accounting for Scan Using TWAIN

To manage the number of jobs scanned by using TWAIN, you need to configure the following settings by using the TWAIN Driver on the computer. Instructions are based on interface elements as they appear in Windows 10.

1 Display the screen

- 1 Click the search box in the taskbar, and enter "TWAIN Driver Setting". Select [TWAIN Driver Setting] in the search list. Displays the TWAIN Driver Settings screen.
- 2 Select the machine, and click [Edit].

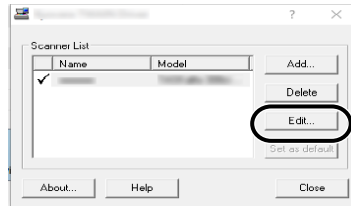

2 Configure the settings

- 1 Click [User Authentication Settings].
- 2 Select [Account], and enter the account ID.



- 3 Click [OK].

Job Accounting for Scan Using WIA

To manage the number of jobs scanned by using WIA, you need to configure the following settings by using the WIA Driver on the computer. Instructions are based on interface elements as they appear in Windows 10.

1 Display the screen

- 1 Please select the Windows [Start] button → [Windows System] → [Control Panel]. Enter "Scanner" into the search field on the control panel. Select [View scanners and cameras] in the search list, then the Scanners and Cameras screen appears.



NOTE

- For Windows 11, select the Windows [Start] button → [All apps] → [Windows Tools] → [Control Panel], in that order. Enter "Scanner" into the search field on the control panel. Select [View scanners and cameras] in the search list then the Scanners and Cameras screen appears.

- 2 Select the same name as this machine from WIA Drivers, and click the [Properties] button.

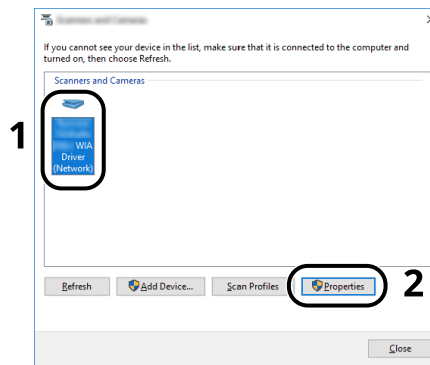

2 Configure the settings

- 1 Select [Account ID] on the [Settings] tab, and enter the Account ID.

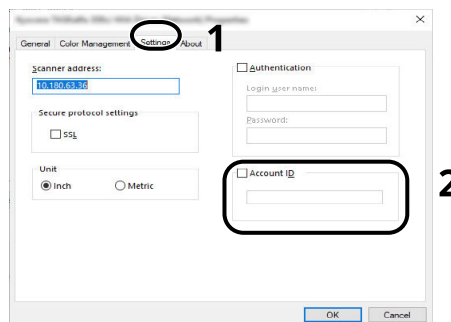

- 2 Click [OK].

Job Accounting for the FAX Transmitted from a Computer

To manage the number of FAX jobs transmitted from the computer, you need to configure the following settings by using the FAX Driver on the computer. Instructions are based on interface elements as they appear in Windows 10.

1 Display the screen

- 1 Select the Windows [Start] button > [→] > [Windows Tools] > [→] > [Control Panel] > [→] > [Devices and Printers].



NOTE

For Windows 11, select the Windows [Start] button → [All apps] → [Windows Tools] → [Control Panel] → [Devices and Printers], in that order.

- 2 Right-click the Fax Driver icon of the machine, and then click the [Printing preferences] menu.
- 3 Click [FAX TX Setting] in the [Printing Preferences] tab.

2 Configure the settings

- 1 Select [Job Accounting] in the [Authentication] tab.

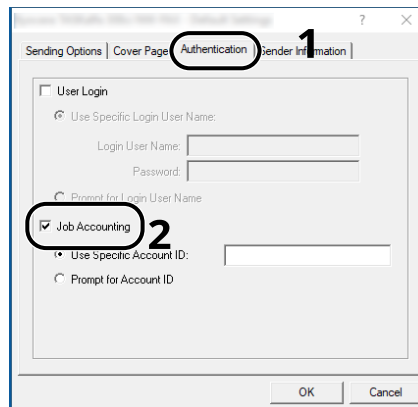

- 2 Set the Job Accounting.

[Use Specific Account ID]

This option can be used to specify an account ID to use the same Account ID for every FAX job. If this option is selected, the user does not have to enter the Account ID for each FAX job.

[Prompt for Account ID]

A screen for entering the Account ID will be displayed when attempting a transmission. The Account ID must be entered each time a transmission is attempted.

- 3 Click [OK].

Configuring Job Accounting

Default Counter Limit

When you add a new account, you can change the default restrictions on the number of sheets used. You can set any number from 1 to 9,999,999.

The items that can be set differ depending on whether or is selected for .

→ [Copier/Printer Count \(page 536\)](#)

1 Display the screen

- 1 [System Menu/Counter] key > [▲] [▼] keys > [User/Job Account] > [OK] key > [▲] [▼] keys > [Job Account.Set.] > [OK] key



NOTE

If the user authentication screen appears, log in with a user who has the privilege to configure this setting. If you do not know your login user name or password, please contact your administrator.

- 2 [▲] [▼] keys > [Default Setting] > [OK] key > [▲] [▼] keys > "Counter Limit" > [OK] key

2 Configure the settings

- 1 Select the item for > [+], [-], or the numeric keys to enter the default restriction on the number of sheets > [OK]

If [Copy/Print Count] is [Individual]

[Copy Restriction]

Sets the default restriction on the number of sheets used for copying.

[Print Restrict.]

Sets the default restriction on the number of sheets used for printing.

Applicable print functions are as follows:

- Print from USB Drive
- Print Report
- Print from PC

[ScanRest.(Other)]

Sets the default restriction on the number of sheets used for scanning (excludes copying).

[FAX Restrict.]

Sets the default restriction on the number of sheets used for sending faxes.

Displays only for fax models.

If [Copy/Print Count] is [Individual]

[Print Restrict.]

Sets the default restriction on the total number of sheets used for copying and printing.

Sets the default restriction on the number of sheets used for scanning (excludes copying).

Sets the default restriction on the number of sheets used for sending faxes.

Displays only for fax models.

Counting the Number of Pages Printed

This counts the number of pages printed. Counts are classified into Total Job Accounting and Each Job Accounting. A new count can also be started after resetting the count data which was stored for a certain period of time.

Total for all departments

This counts the number of pages for each account. In addition, you can reset the counts for all accounts at the same time.

Total by department

This counts the number of pages for each account and resets the counts by account. When checking Each Job Accounting, select the account for which you want to check the count.

The number of sheets used is counted according to the following items.

[Printed Pages]

The number of copies, printers and the total for both is displayed. You can also check the number of each used pages in [FAX RX Pages][Duplex Pages][Combine Pages].

Item	Description
[Copy/Print Pages]	The number of copies, printers and the total for both is displayed. Select the [▶] key to display the next page. Select the [◀] key to return to the previous page.
[FAX RX Pages]	Number of faxes received is displayed.
[Total PrintPages]	The total number of pages used is displayed.
[Duplex Pages]	[1-sided], [Duplex] and the total number of used pages can be checked. Select the [▶] key to display the next page. Select the [◀] key to return to the previous page.
[Combine Pages]	[None] (None combine) [2 in 1] [4 in 1] and the total number of used pages can be checked. Select the [▶] key to display the next page. Select the [◀] key to return to the previous page.

[Scanned Pages]

Displays the number of pages scanned for copying, for faxing, and for other functions, as well as the total number of pages used.

Select the [▶] key to display the next page. Select the [◀] key to return to the previous page.

[FAX TX Pages]

Number of pages faxed is displayed.

[FAX TX Time]

Total duration of FAX transmissions is displayed.

[Counter Reset]

Resets the counter. Select [Reset] on the confirmation screen.

Counting the Number of Pages for All Accounts

This counts the number of pages for each account. In addition, you can reset the counts for all accounts at the same time.

Counting the Number of Pages for Each Account

This counts the number of pages for each account and resets the counts by account. When checking Each Job Accounting, select the account for which you want to check the count.

1 Display the screen

- 1 [System Menu/Counter] key > [▲] [▼] keys > [User/Job Account] > [OK] key > [▲] [▼] keys > [Job Account.Set.] > [OK] key > [▲] [▼] keys > [Each Job Account] > [OK] key



NOTE

If the user authentication screen appears, log in with a user who has the privilege to configure this setting. If you do not know your login user name or password, please contact your administrator.

2 Check the number of pages.

- 1 Select the department to view the consolidation > [OK] key



NOTE

- Select [Account Name] or [Account ID] to sort the account list.
 - To display an account other than your own account, select [Others].
-

- 2 Check the count.

Select [Counter Reset] > [Yes] to reset the counter.

- 3 Confirm the count and select the [OK] key.

Print Accounting Report

The total pages counted of all relevant accounts can be printed as an accounting report.

1 Prepare paper.

Check that A4 or Letter paper is loaded in the cassette.

2 Display the screen

1 [System Menu/Counter] key > [▲] [▼] keys > [User/Job Account] > [OK] key



NOTE

If the user authentication screen appears, log in with a user who has the privilege to configure this setting. If you do not know your login user name or password, please contact your administrator.

2 [▲] [▼] keys > [Job Account.Set.] > [OK] key

3 Execute printing.

1 [▲] [▼] keys > [Account. Report] > [OK] key > [Yes]

Account. Report is printed.

Reports have different formats depending on how the count of printers is administered. If count by paper size is being performed, then the report will be printed per size.

Using Job Accounting

This section explains procedures while setting job accounting.

Login

If job accounting is enabled, an account ID entry screen appears each time you use this machine.

1 Enter the account ID using the numeric keys > [Login]



NOTE

- If you entered a wrong character, select [Clear] key and enter the account ID again.
 - If the entered account ID does not match the registered ID, a warning beep will sound and login will fail. Enter the correct account ID.
 - By selecting [Counter], you can refer to the number of pages printed and the number of pages scanned.
-

If user login administration is enabled, the screen to enter the login user name and password appears instead of the screen to enter the account ID. Enter a login user name and password to login. If the user has already registered the account information, the account ID entry would be skipped.

➔ [Adding a User \(Local User List\) \(page 487\)](#)

2 Proceed to complete the rest of the steps.

Logout

- 1** When the operation is complete, select the [Logout] key. Return to the Enter Account ID screen.

Apply Limit

This specifies how the machine behaves when the counter has reached the limit of restriction. The action is as follows:

Item	Description
[Immediately]	Job stops when the counter reaches its limit. If sending or storing in the box is already underway, prohibition will become effective from the next job.
[Subsequently]	The print or scan job currently underway will continue but the subsequent job will be rejected.
[Alert Only]	Job continues while displaying an alert message.

1 Display the screen

- 1 [System Menu/Counter] key > [▲] [▼] keys > [User/Job Account] > [OK] key



NOTE

If the user authentication screen appears, log in with a user who has the privilege to configure this setting. If you do not know your login user name or password, please contact your administrator.

- 2 [▲] [▼] keys > [Job Account.Set.] > [OK] key > [▲] [▼] keys > [Default Setting] > [OK] key > [▲] [▼] keys > [Apply Limit] > [OK] key

2 Configure the settings

- 1 Select, [Immediately], [Subsequently], or [Alert Only] > key [OK]

Copier/Printer Count

You can select how the copying and printing page counts are shown - either the total of both or each of copying and printing individually. The selection may influence restriction on the count and count method.

- ➔ [Restricting the Use of the Machine \(page 520\)](#)
- ➔ [Counting the Number of Pages Printed \(page 530\)](#)
- ➔ [Print Accounting Report \(page 532\)](#)

1 Display the screen

- 1 [System Menu/Counter] key > [▲] [▼] keys > [User/Job Account] > [OK] key > [▲] [▼] keys > [OK] key > [▲] [▼] keys > [Job Account.Set.] > [OK] key



NOTE

If the user authentication screen appears, log in with a user who has the privilege to configure this setting. If you do not know your login user name or password, please contact your administrator.

- 2 [▲] [▼] keys > [Default Setting] > [OK] key > [▲] [▼] keys > [Copy/Print Count] > [OK] key

2 Configure the settings

- 1 Select [Total] or [Individual].

Unknown User Settings

Unknown ID Job

This specifies the behavior for handling the jobs sent with unknown or unsend login user names or User ID. If the User Login is set to invalid and Job Accounting is set to valid, follow the procedure when the Account ID is unknown.

1 Display the screen

- 1 [System Menu/Counter] key > [▲] [▼] keys > [User/Job Account] > [OK] key



NOTE

If the user authentication screen appears, log in with a user who has the privilege to configure this setting. If you do not know your login user name or password, please contact your administrator.

- 2 [▲] [▼] keys > [Unknown User] > [OK] key > [▲] [▼] keys > [Unknown ID Job] > [OK] key

2 Configure the settings

Select [Reject] or [Permit].

[Permit]

The job is permitted to be printed.

[Reject]

The job is rejected (not printed).

Registering Information for a User whose ID is Unknown

If you register user information for a user whose ID is unknown, you can check information on the Job Status or Job History screens. In addition, you can restrict available functions.

NOTE

This function is displayed when [Unknown ID Job] is set to [Permit].

→ [Unknown ID Job \(page 537\)](#)

1 Display the screen

- 1 [System Menu/Counter] key > [▲] [▼] keys > [User/Job Account] > [OK] key

NOTE

If the user authentication screen appears, log in with a user who has the privilege to configure this setting. If you do not know your login user name or password, please contact your administrator.

- 2 [▲] [▼] keys > [Unknown User] > [OK] key [▲] [▼] keys > [User Property] > [OK] key

2 Enter the user information.

Select [Edit] or [Change], [Detail], enter each detail, then select [OK] key.

Select the [▶] key to display the next page. Select the [◀] key to return to the previous page.

[User Name]

Enter the name displayed on the user list (up to 32 characters).

[Furigana]

[Account Name]

Register an account ID for a user whose ID is unknown.

[Authoriz. Rules]

Set usage authority.

The following restriction items are available:

[Print Restrict.]

Select whether or not use of the print function of the printer is prohibited.

Applicable print functions are as follows:

- Print from PC

10 Troubleshooting

Regular Maintenance

Cleaning

Clean the machine regularly to ensure optimum printing quality.



CAUTION

For safety, always unplug the power cord before cleaning the machine.

Cleaning Platen

Wipe the inside of the document processor and the platen with a soft cloth dampened with alcohol or mild detergent.

 **IMPORTANT**

Do not use thinner or other organic solvents.

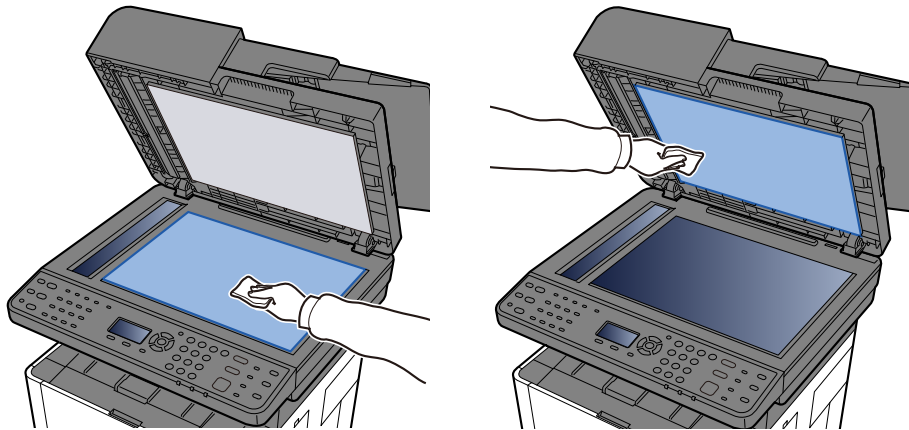

Cleaning Slit Glass

When using the document processor, clean the slit glass surface and the reading guide with the dry cloth.

✔ **IMPORTANT**

Do not use water, soap or solvents for cleaning.

💡 **NOTE**

Dirt on the slit glass or the reading guide may cause black streaks to appear in the output.

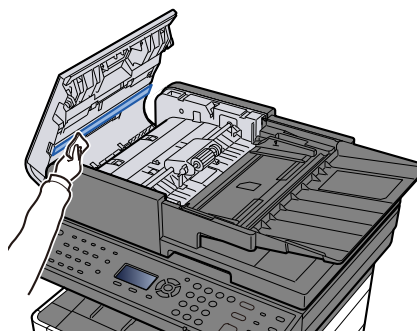
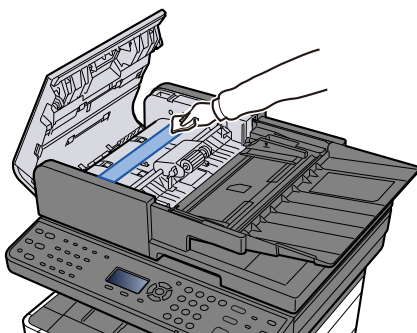
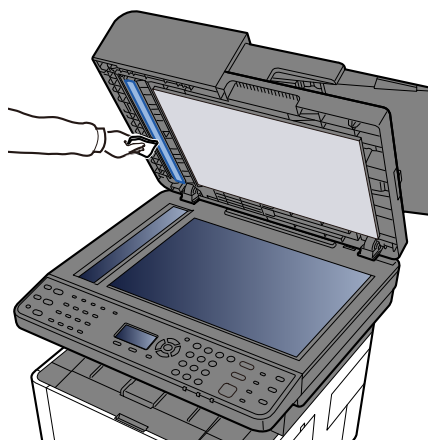
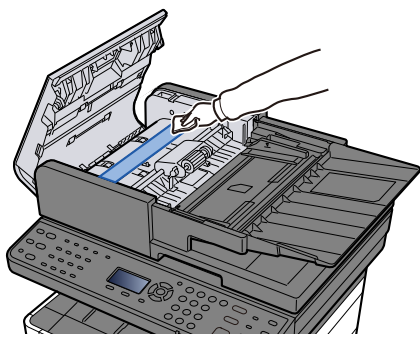

Clean the inside of the main unit

To maintain optimum print quality, it is also recommended that the inside of the machine be cleaned when the toner container is replaced and when vertical streaks appear.

1 Open the top cover.

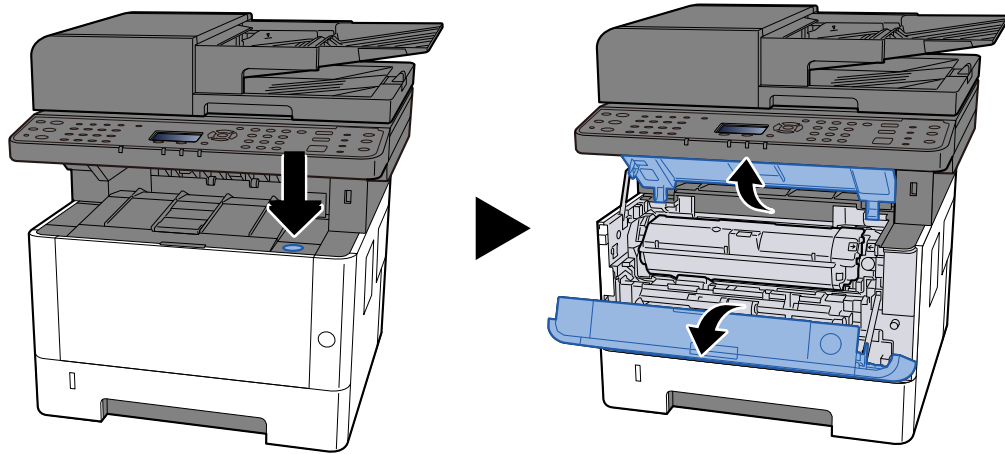

2 Remove the toner container and developer unit

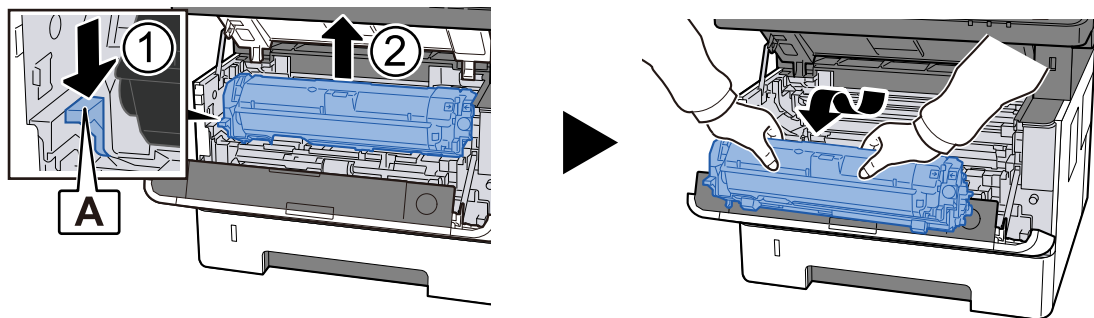

✔ **IMPORTANT**

Do not touch the developing roller or subject it to impact. Print quality will deteriorate.

3 Place the toner container and developer unit on a level, clean surface.

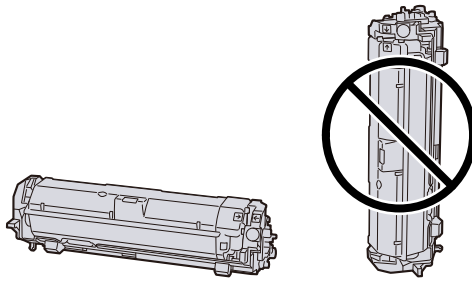

✔ **IMPORTANT**

Do not place the toner container and developer unit upright.

4 Remove the drum unit

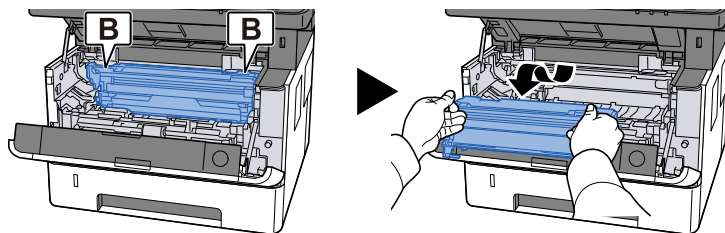

✔ **IMPORTANT**

Do not touch the drum part or subject it to impact. Also, if exposed to direct sunlight or strong light, print quality will deteriorate.

5 Place the removed drum unit on a level, clean surface.

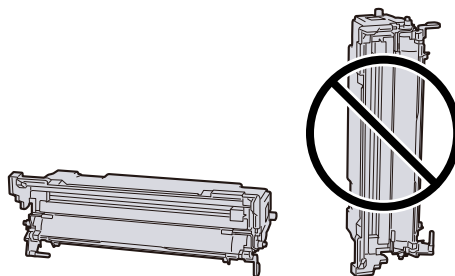

✔ **IMPORTANT**

Do not stand the drum unit upright.

- 6** Use a soft, dry cloth to wipe off any paper dust or dirt from the metal resist rollers.

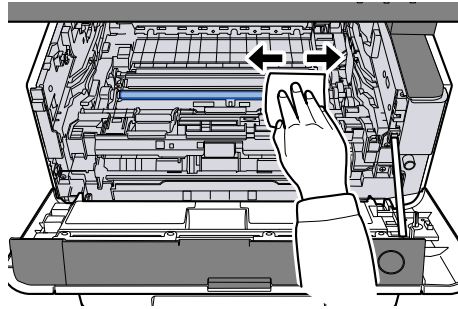

- 7** Slide the charger cleaner knob on the upper side of the drum unit left and right 2 or 3 times.

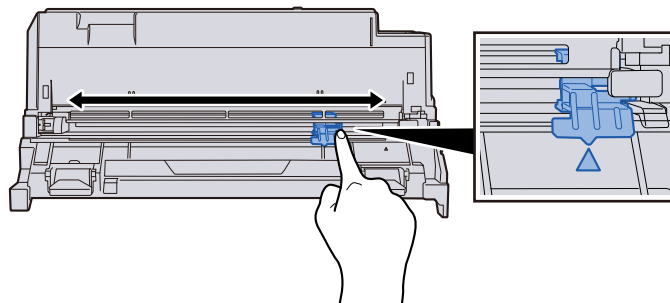

✓ IMPORTANT

When cleaning the charger wire for the first time, remove the tape that secures the charger cleaner knob.

After cleaning, return the charger cleaner knob to its original position (CLEANER HOME POSITION)

- 8** Return the drum unit

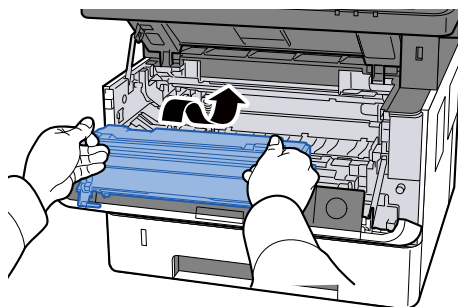

- 9** Return the toner container and drum unit

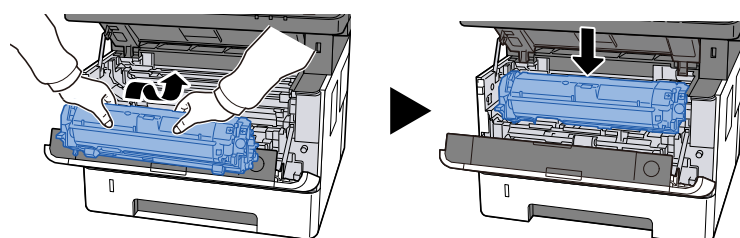

10 Close the top cover.

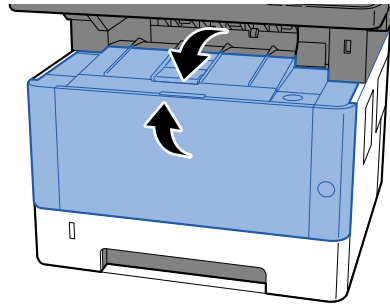

Replacing the Toner Container

When toner is empty, the following message will be displayed. Replace the toner container.

"Toner is empty."

When toner runs low, the following message will be displayed. Make sure you have a new toner container available for replacement.

"Toner %s is low. (Replace when empty.)"

Toner color	Toner container model number
Black	TK-1272

The number of sheets that can be printed with one toner container depends on the print data (how much toner is used). Compliant with JIS X 6932 (ISO/IEC 19798), when the EcoPrint mode is turned [Off], the average number of printable sheets of the toner container is as follows: (When printing with A4.)

Toner color	Toner container yield (number of prints)
Black	10,000-sheets

 **NOTE**

- The average number of printable sheets of the toner container that comes with this machine is 3,600 sheets.
- For the toner container, always use a genuine toner container. Using a toner container that is not genuine may cause image defects and product failure.
- The memory chip in the toner container of this product stores information necessary for improving customer convenience, operation of the recycling system for used toner containers, and planning and development of new products. The stored information does not include information that makes it possible to identify individuals, and is only used anonymously for the above purposes.

 **CAUTION**

Do not attempt to incinerate parts which contain toner. Dangerous sparks may cause burns.

1 Open the top cover.

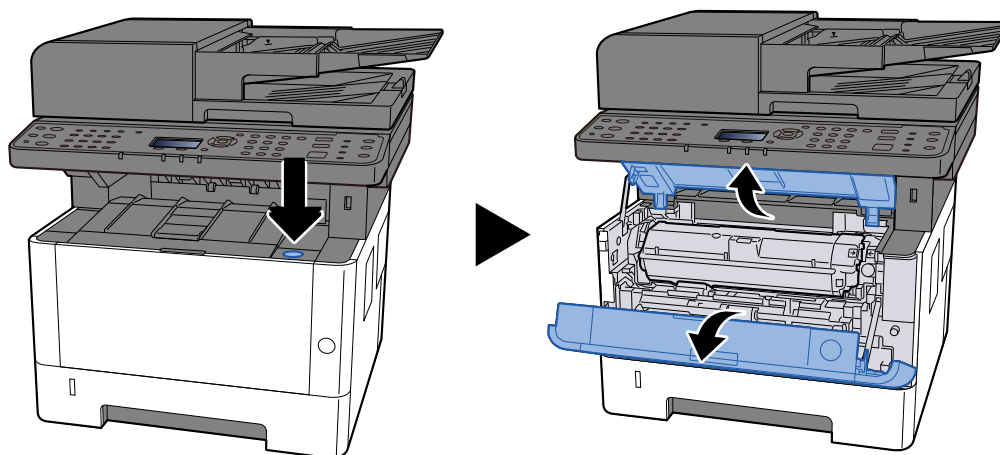

2 unlock

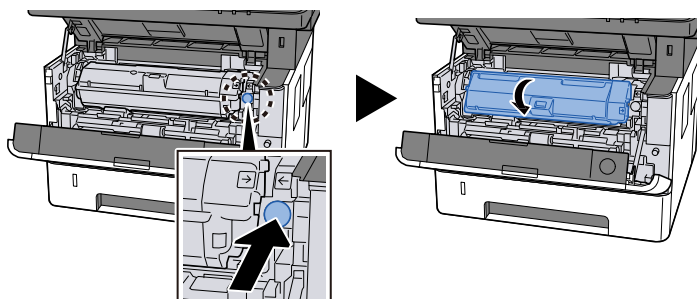

3 Remove the toner container.

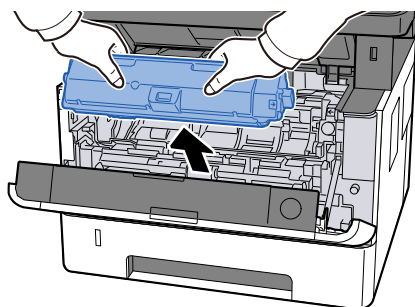

4 Put used toner container into the plastic waste bag.

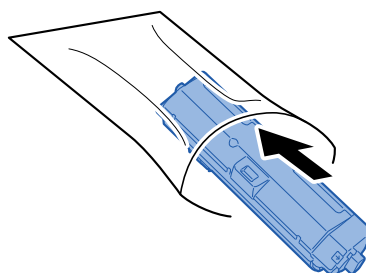

5 Remove the new toner container from the box.

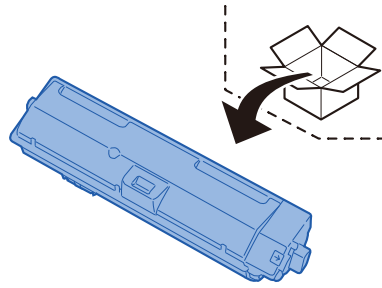

✓ IMPORTANT

Do not touch the points shown below.

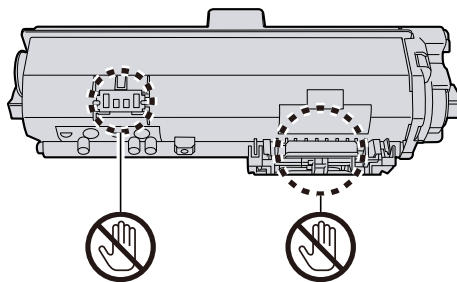

6 Shake the toner container.

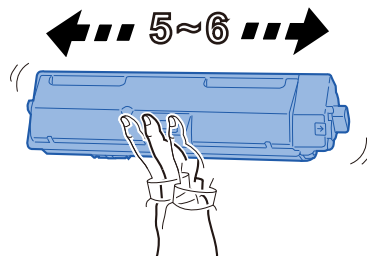

7 Install the toner container.

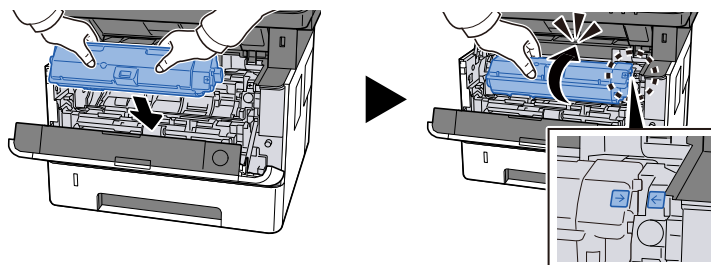

8 Close the top cover.

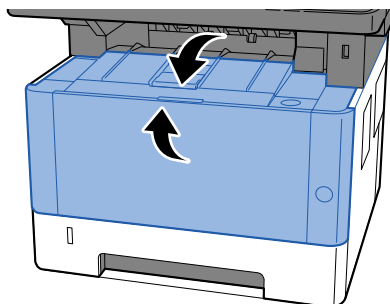

✔ IMPORTANT

- If the front cover does not close, check that the new toner container is installed correctly.
 - Return the exhausted toner container to your dealer or service representative. The collected toner container will be recycled or disposed in accordance with the relevant regulations.
-

Troubleshooting

Solving Malfunctions

If a problem occurs with your machine, look into the checkpoints and perform procedures indicated on the following pages. The table below provides general guidelines for problem solving. If the problem persists, contact your service representative.



When contacting us, the serial number will be necessary. To check the serial number, refer to the following:

➔ [Preface \(page 2\)](#)

Machine Operation Trouble

The application does not start up

Is the auto panel reset setting time set too short?

Check the set time for auto panel reset.

1 [System Menu/Counter] key > [▲] [▼] keys > [Common Settings] > [OK] key > [▲] [▼] keys > [Timer Setting] > [OK] key > [▲] [▼] keys > [PanelReset Timer] > [OK] key

2 **Set the panel reset time to 30 seconds or more**

It can be set in the range of 5 to 495 seconds (in 5 second increments).

The screen does not respond when the power switch is turned on

Is the machine plugged in?

- 1 Plug in the power cord that comes with this machine to an outlet.**
Make sure the power plug is securely plugged in.

Machine does not print even when [Start] is pressed

Is there a message displayed on the screen?

If a message is displayed on the screen, you may not be able to operate it depending on what is displayed.

Determine the appropriate response to the message and respond accordingly.

Is the machine in Sleep mode?

Operation can't be done when it is in sleep mode.

- 1 Press the [Energy Saver] key.**

Blank sheets are ejected



Is the original set correctly?

Placing Originals on the Platen

1 Put the scanning side facedown.

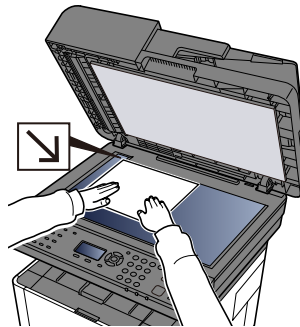

2 Align it flush against the original size indicator plates with the back left corner as the reference point.



NOTE

For details on Original Orientation, refer to the following:

➔ [Original Size \(page 286\)](#)

Placing Originals in the Document Processor

- 1 Open the document tray and adjust the document width guide to the document size.**

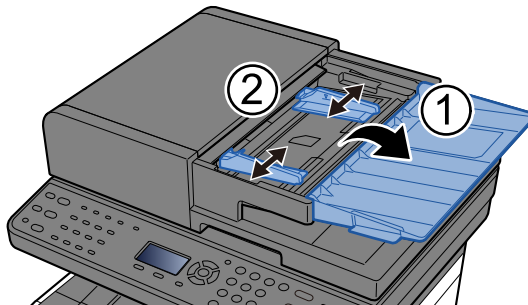

- 2 Load paper.**

- 1** Put the side to be scanned (or the first side of two-sided originals) face-up.

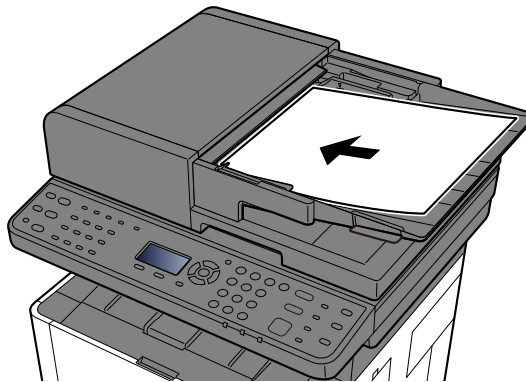

 **NOTE**

For details on Original Orientation, refer to the following:

➔ [Orig.Orientation \(page 291\)](#)

 **IMPORTANT**

Confirm that the original width guides exactly fit the originals. If there is a gap, readjust the original width guides. The gap may cause the originals to jam.

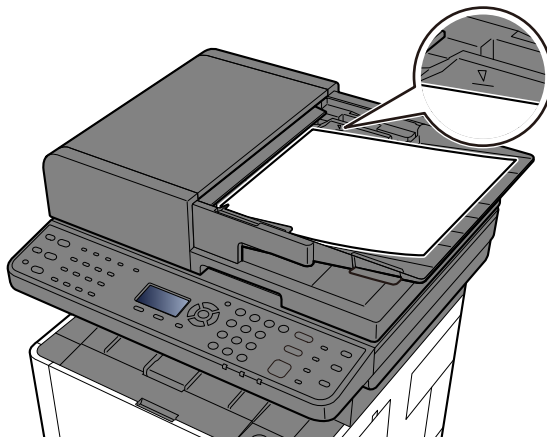

Ensure that loaded originals do not exceed the level indicator. Exceeding the maximum level may cause the originals to jam.

Originals with punched holes or perforated lines should be placed with the punched holes or perforated lines on the right side (so that they will be scanned last).

- 2 Open the original stopper. (If the original size is Folio/Legal)

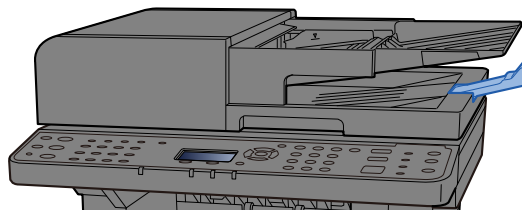

Is the application software set correctly?

Check the settings of the application software.

Paper often jams

Is the paper loaded correctly?

Load the paper correctly.

When loading paper in a cassette

- 1 Pull the cassette completely out of the machine.**

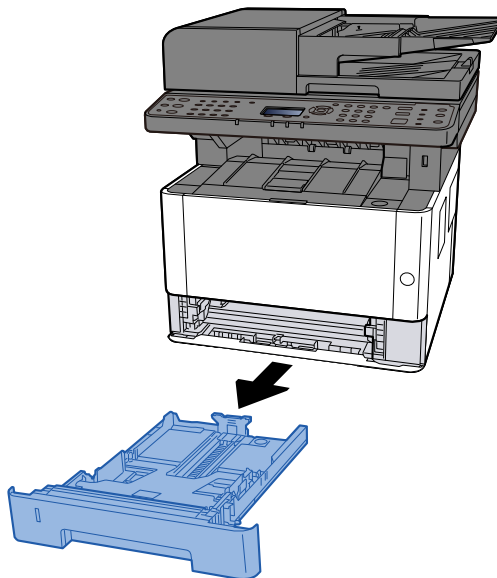

 **NOTE**

If the baseplate is rising, push the baseplate until it locks.

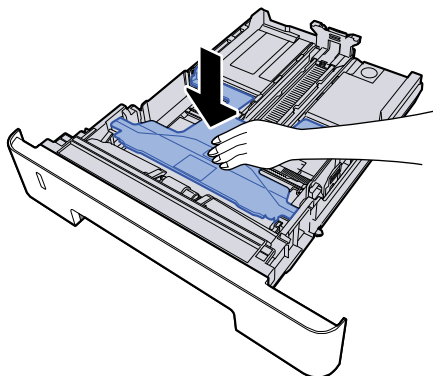

2 Adjust the cassette size.

- 1 Adjust the paper length guide to the paper size required. Press the paper length adjusting tab and slide the guides to the paper size required.

Paper sizes are marked on the cassette.

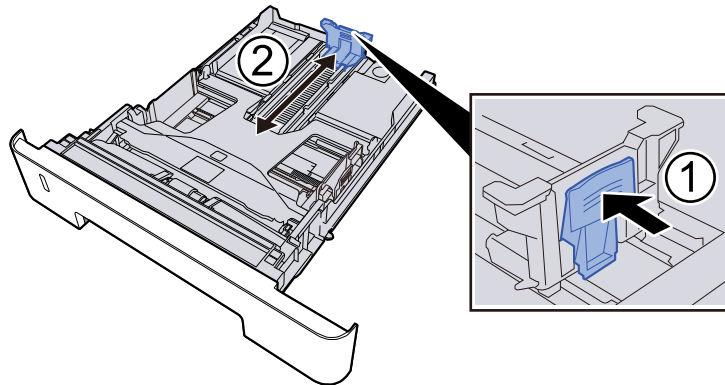

✔ IMPORTANT

When using Folio, Oficio II, or Legal

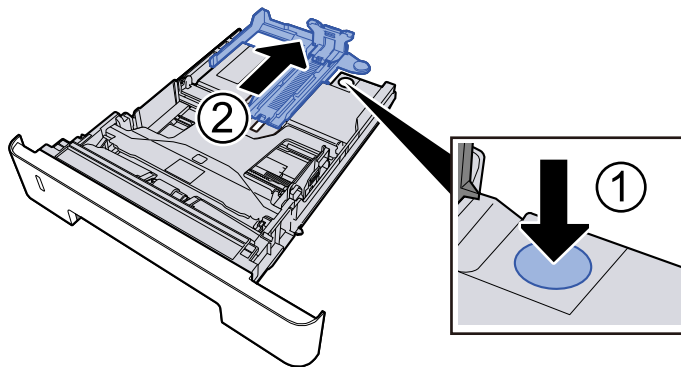

- 2 Adjust the position of the paper width guides located on the left and right sides of the cassette. Press the paper width adjusting tab and slide the guides to the paper size required.

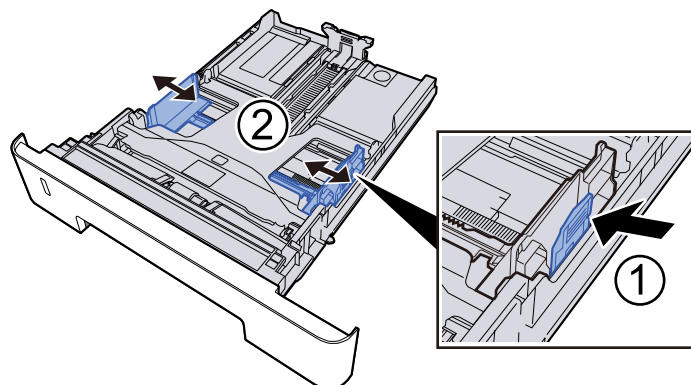

3 Load paper

- 1 Fan the paper, then tap it on a level surface to avoid paper jams or skewed printing.
- 2 Load the paper in the cassette.

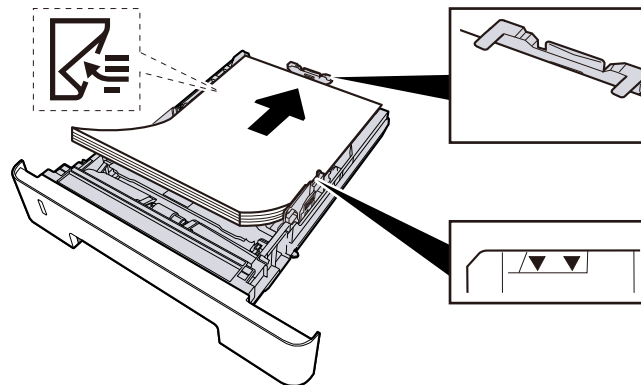

✔ IMPORTANT

- Load the paper with the print side facing down.
 - After removing new paper from its packaging, fan out the paper before loading it in the cassettes.
 - ➔ [Precaution for Loading Paper \(page 131\)](#)
 - Before loading the paper, be sure that it is not curled or folded. Paper that is curled or folded may cause paper jams.
 - Ensure that the loaded paper does not exceed the level indicator.
 - If paper is loaded without adjusting the paper length guide and paper width guide, the paper may skew or become jammed.
-

4 Gently push the cassette back in.

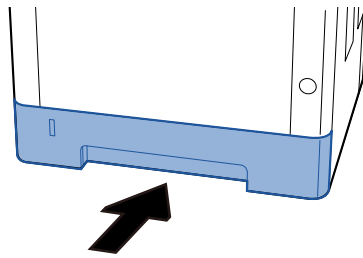

IMPORTANT

Push all cassettes all the way in. If they are not pushed all the way in, they may cause a jam.

NOTE

There is a paper gauge on the right side of the front of the cassette. The display changes up and down to match the remaining amount of paper.

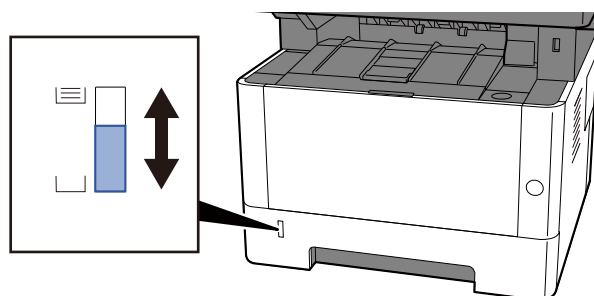

Remove the paper from the cassette once if there is no improvement, turn it over and reload it, or change the loading direction by rotating the paper 180 degrees.

➔ [Precaution for Loading Paper \(page 131\)](#)

When loading paper in the multipurpose tray

1 Open the multipurpose tray.

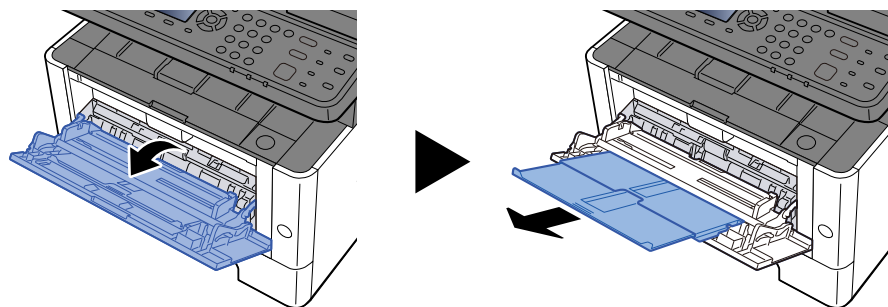

2 Adjust the multipurpose tray size.

Paper sizes are marked on the multipurpose tray.

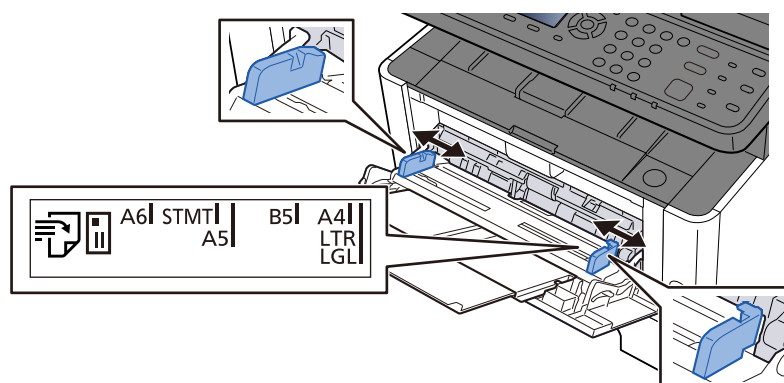

3 Load paper

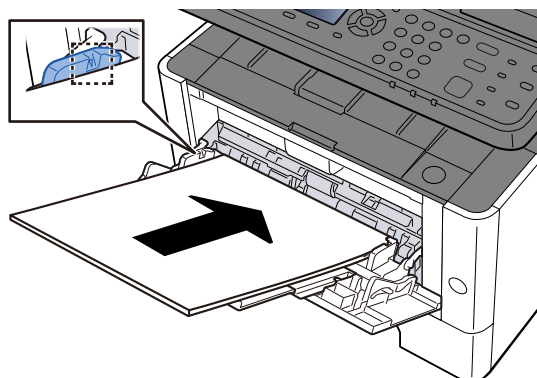

Insert the paper along the paper width guides into the tray until it stops.

After removing new paper from its packaging, fan the paper before loading it in the multipurpose tray.

➔ [Precaution for Loading Paper \(page 131\)](#)

✔ IMPORTANT

- When loading the paper, keep the print side facing up.
- Curled paper must be uncurled before use.
- When loading paper into the multipurpose tray, check that there is no paper left over in the tray from a previous job before loading the paper. If there is just a small amount of paper left over in

the multipurpose tray and you want to add more, first remove the left-over paper from the tray and include it with the new paper before loading the paper back into the tray.

- If there is a gap between the paper and the paper width guides, readjust the guides to fit the paper in order to prevent skewed feeding and paper jams.
- Ensure that the loaded paper does not exceed the load limits.

When you load envelopes or cardstock in the multipurpose tray, load the paper with the print side facing up. For the procedure for printing, refer to the Printer Driver User Guide.

➔ **Printer Driver User Guide**

Example: When printing the address.

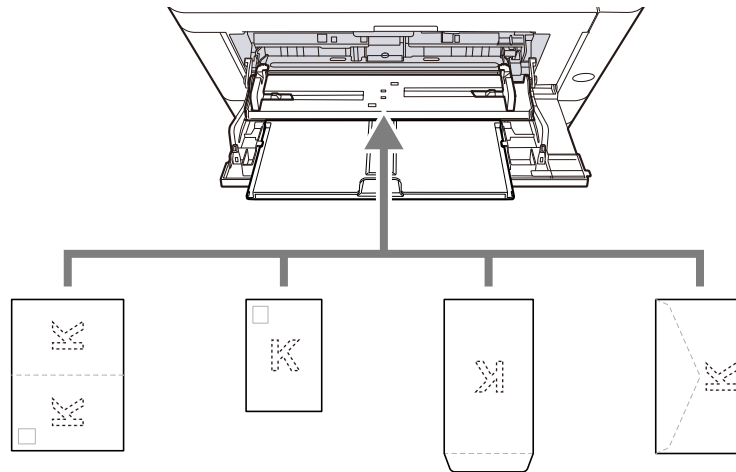

- Oufuku hagaki (Return postcard)
- Hagaki (Cardstock)
- Vertical envelope (open opening)
- Horizontal envelope (close opening)

✔ **IMPORTANT**

- Use unfolded Oufuku hagaki (Return postcard).
- How to load envelopes (orientation and facing) will differ depending on the type of envelope. Be sure to load it in correctly, otherwise printing may be done in the wrong direction or on the wrong face.

💡 **NOTE**

When you load envelopes in the multipurpose tray, select the envelope type by referring to the following:

➔ [\[MF Tray Set.\] \(page 435\)](#)

4 Specify the type of paper loaded in the multipurpose tray using the operation panel.

➔ [Specifying Paper Size and Media Type \(page 140\)](#)

Is the paper of the supported type? Is it in good condition?

Remove the paper from the cassette, turn it over, and then reload it.

➔ [Precaution for Loading Paper \(page 131\)](#)

Is the paper curled, folded or wrinkled?

Replace the paper with new paper.

➔ [Precaution for Loading Paper \(page 131\)](#)

Are there any loose scraps or jammed paper in the machine?

Remove the jammed paper.

➔ [Clearing Paper Jams \(page 740\)](#)

Two or more sheets are overlaps when ejected (multi feeding)

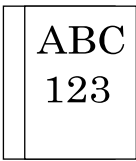

Is the paper loaded correctly?

Load the paper correctly.

When loading paper in a cassette

- 1 Pull the cassette completely out of the machine.**

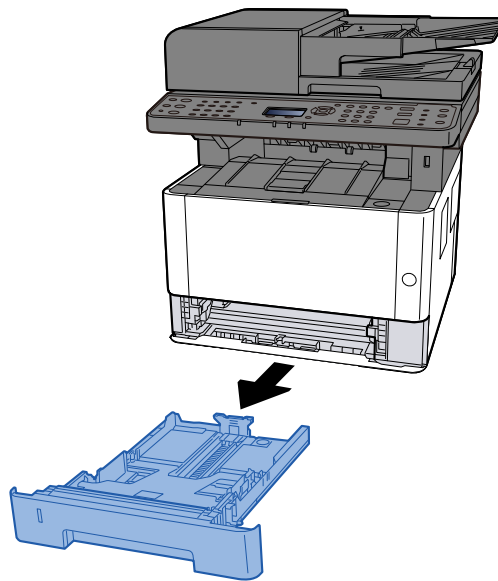

NOTE

If the baseplate is rising, push the baseplate until it locks.

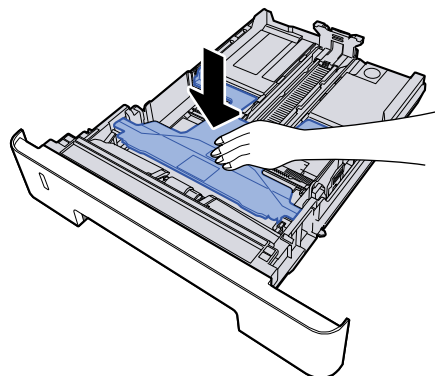

2 Adjust the cassette size.

- 1 Adjust the paper length guide to the paper size required. Press the paper length adjusting tab and slide the guides to the paper size required.

Paper sizes are marked on the cassette.

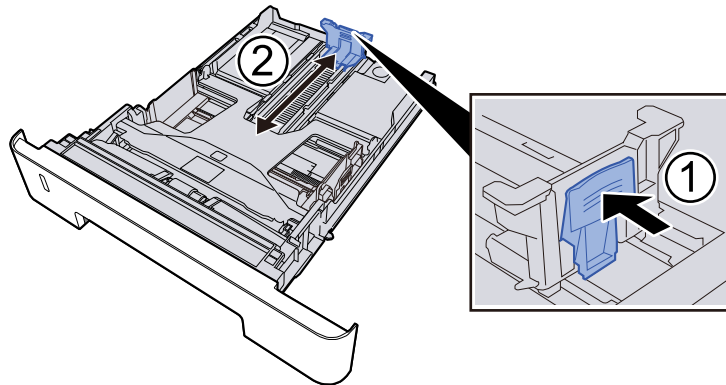

✔ IMPORTANT

When using Folio, Oficio II, or Legal

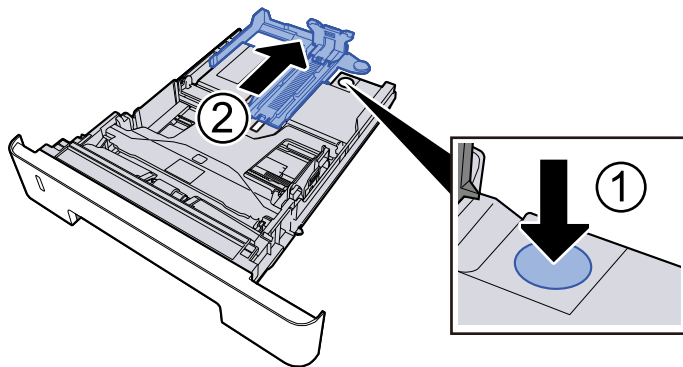

- 2 Adjust the position of the paper width guides located on the left and right sides of the cassette. Press the paper width adjusting tab and slide the guides to the paper size required.

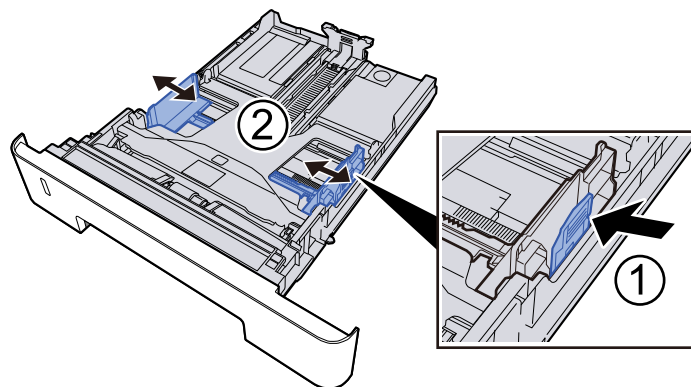

3 Load paper

- 1 Fan the paper, then tap it on a level surface to avoid paper jams or skewed printing.
- 2 Load the paper in the cassette.

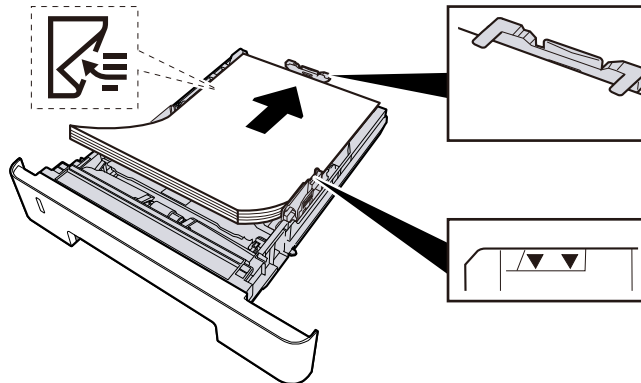

 **IMPORTANT**

- Load the paper with the print side facing down.
 - After removing new paper from its packaging, fan out the paper before loading it in the cassettes.
 - ➔ [Precaution for Loading Paper \(page 131\)](#)
 - Before loading the paper, be sure that it is not curled or folded. Paper that is curled or folded may cause paper jams.
 - Ensure that the loaded paper does not exceed the level indicator.
 - If paper is loaded without adjusting the paper length guide and paper width guide, the paper may skew or become jammed.
-

4 Gently push the cassette back in.

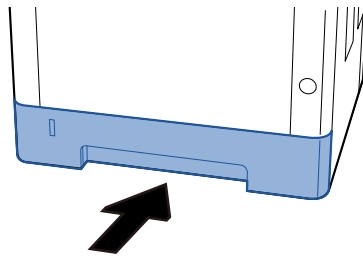

 **IMPORTANT**

Push all cassettes all the way in. If they are not pushed all the way in, they may cause a jam.

 **NOTE**

There is a paper gauge on the right side of the front of the cassette. The display changes up and down to match the remaining amount of paper.

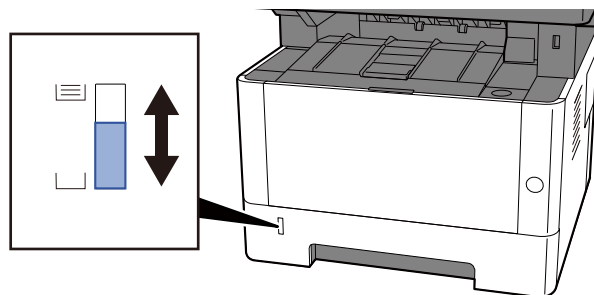

Remove the paper from the cassette once if there is no improvement, turn it over and reload it, or change the loading direction by rotating the paper 180 degrees.

➔ [Precaution for Loading Paper \(page 131\)](#)

When loading paper in the multipurpose tray

1 Open the multipurpose tray.

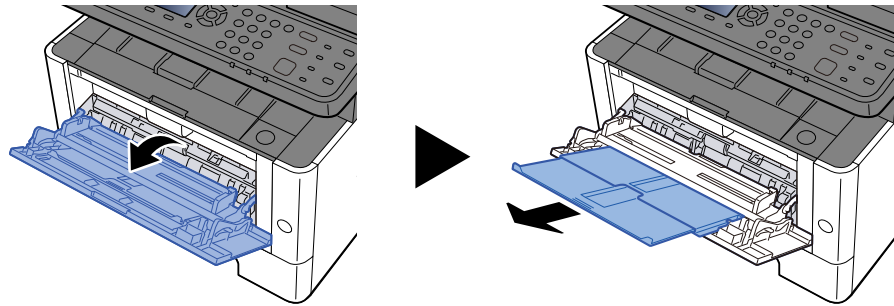

2 Adjust the multipurpose tray size.

Paper sizes are marked on the multipurpose tray.

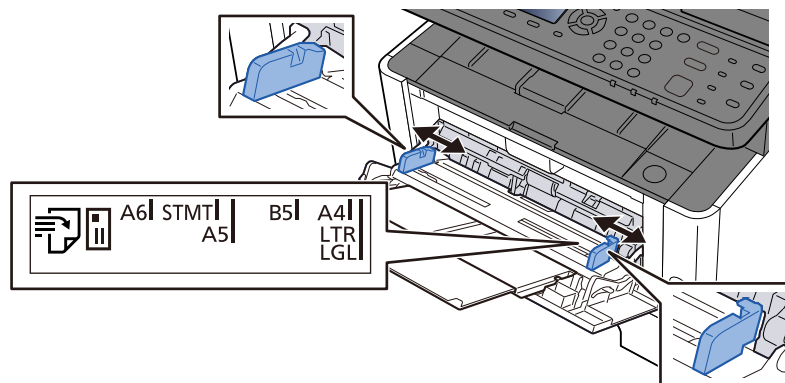

3 Load paper

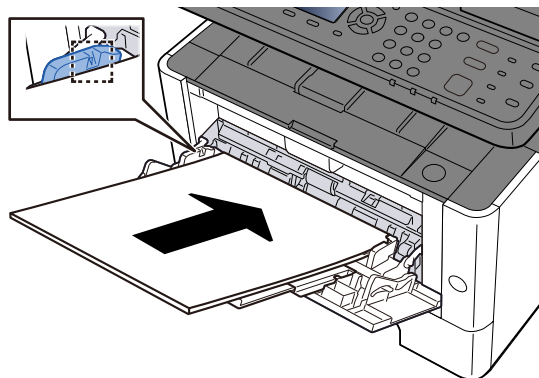

Insert the paper along the paper width guides into the tray until it stops.

After removing new paper from its packaging, fan the paper before loading it in the multipurpose tray.

➔ [Precaution for Loading Paper \(page 131\)](#)

✔ IMPORTANT

- When loading the paper, keep the print side facing up.
- Curled paper must be uncurled before use.
- When loading paper into the multipurpose tray, check that there is no paper left over in the tray from a previous job before loading the paper. If there is just a small amount of paper left over in

the multipurpose tray and you want to add more, first remove the left-over paper from the tray and include it with the new paper before loading the paper back into the tray.

- If there is a gap between the paper and the paper width guides, readjust the guides to fit the paper in order to prevent skewed feeding and paper jams.
- Ensure that the loaded paper does not exceed the load limits.

When you load envelopes or cardstock in the multipurpose tray, load the paper with the print side facing up. For the procedure for printing, refer to the Printer Driver User Guide.

➔ **Printer Driver User Guide**

Example: When printing the address.

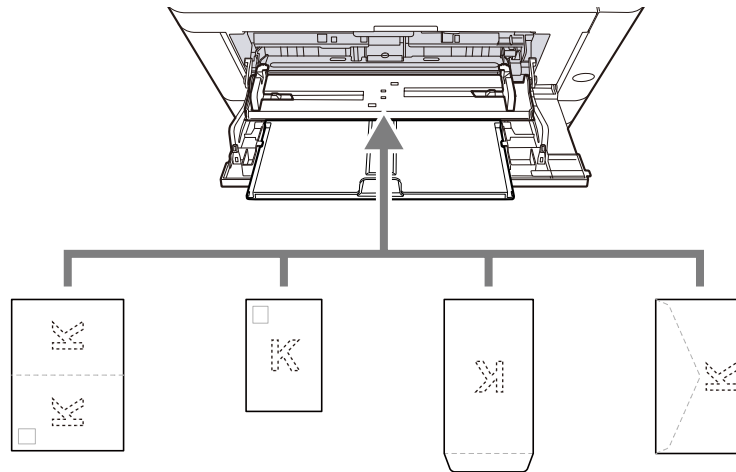

- Oufuku hagaki (Return postcard)
- Hagaki (Cardstock)
- Vertical envelope (open opening)
- Horizontal envelope (close opening)

✔ **IMPORTANT**

- Use unfolded Oufuku hagaki (Return postcard).
- How to load envelopes (orientation and facing) will differ depending on the type of envelope. Be sure to load it in correctly, otherwise printing may be done in the wrong direction or on the wrong face.

💡 **NOTE**

When you load envelopes in the multipurpose tray, select the envelope type by referring to the following:

➔ [\[MF Tray Set.\] \(page 435\)](#)

4 Specify the type of paper loaded in the multipurpose tray using the operation panel.

➔ [Specifying Paper Size and Media Type \(page 140\)](#)

Is the paper damp?

Replace the paper with new paper.

➔ [Precaution for Loading Paper \(page 131\)](#)

Printouts are wrinkled

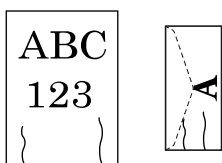

Is the paper loaded correctly?

Load the paper correctly.

When loading paper in a cassette

- 1 Pull the cassette completely out of the machine.**

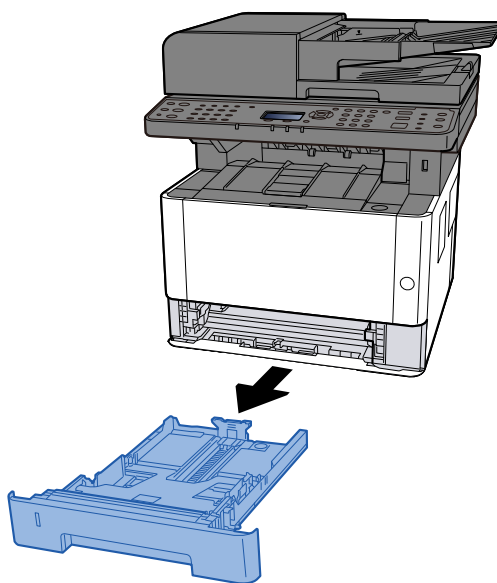

NOTE

If the baseplate is rising, push the baseplate until it locks.

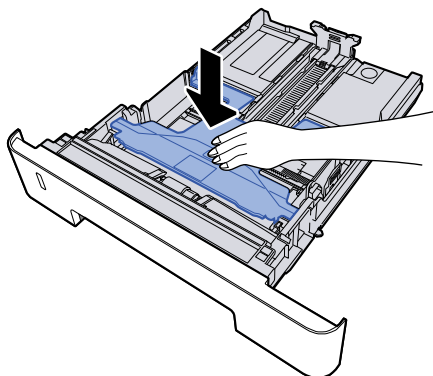

2 Adjust the cassette size.

- 1 Adjust the paper length guide to the paper size required. Press the paper length adjusting tab and slide the guides to the paper size required.

Paper sizes are marked on the cassette.

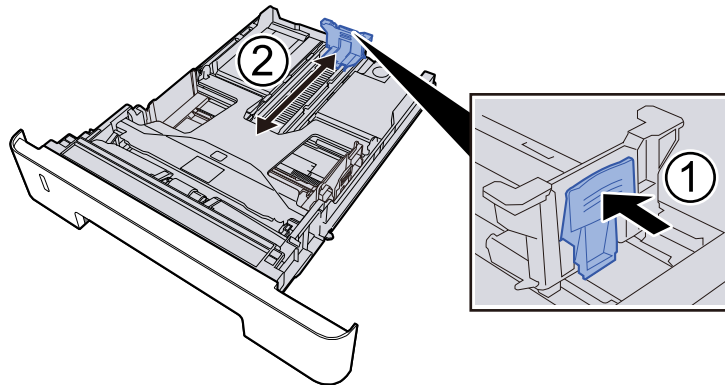

✔ IMPORTANT

When using Folio, Oficio II, or Legal

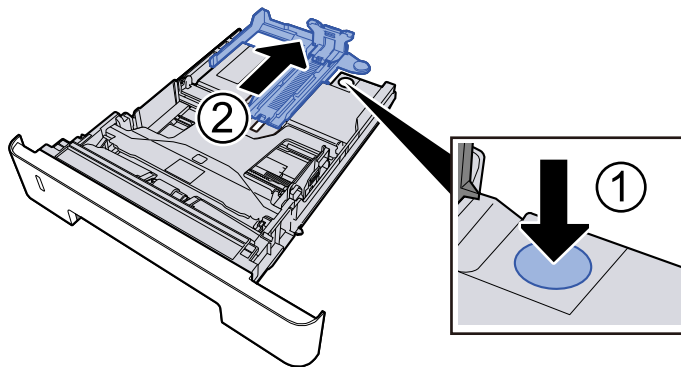

- 2 Adjust the position of the paper width guides located on the left and right sides of the cassette. Press the paper width adjusting tab and slide the guides to the paper size required.

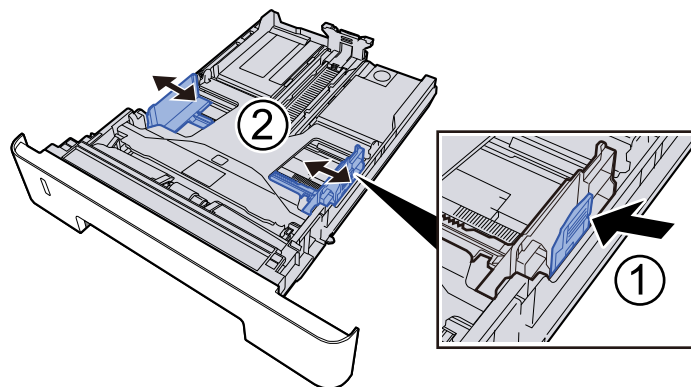

3 Load paper

- 1 Fan the paper, then tap it on a level surface to avoid paper jams or skewed printing.
- 2 Load the paper in the cassette.

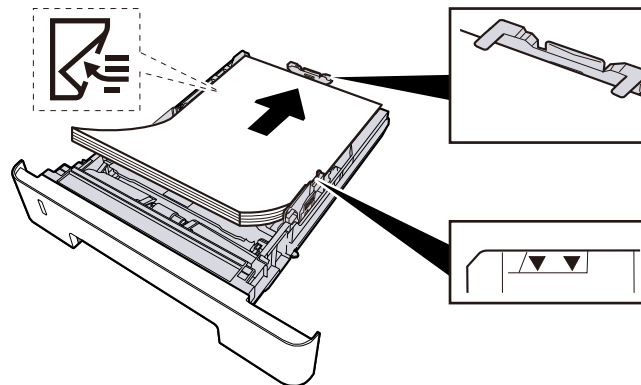

✓ IMPORTANT

- Load the paper with the print side facing down.
 - After removing new paper from its packaging, fan out the paper before loading it in the cassettes.
 - ➔ [Precaution for Loading Paper \(page 131\)](#)
 - Before loading the paper, be sure that it is not curled or folded. Paper that is curled or folded may cause paper jams.
 - Ensure that the loaded paper does not exceed the level indicator.
 - If paper is loaded without adjusting the paper length guide and paper width guide, the paper may skew or become jammed.
-

4 Gently push the cassette back in.

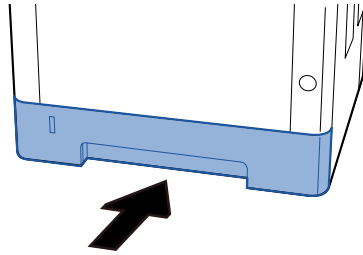

✓ IMPORTANT

Push all cassettes all the way in. If they are not pushed all the way in, they may cause a jam.

💡 NOTE

There is a paper gauge on the right side of the front of the cassette. The display changes up and down to match the remaining amount of paper.

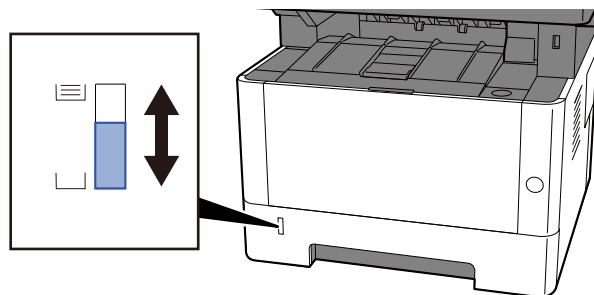

Remove the paper from the cassette once if there is no improvement, turn it over and reload it, or change the loading direction by rotating the paper 180 degrees.

➔ [Precaution for Loading Paper \(page 131\)](#)

When loading paper in the multipurpose tray

1 Open the multipurpose tray.

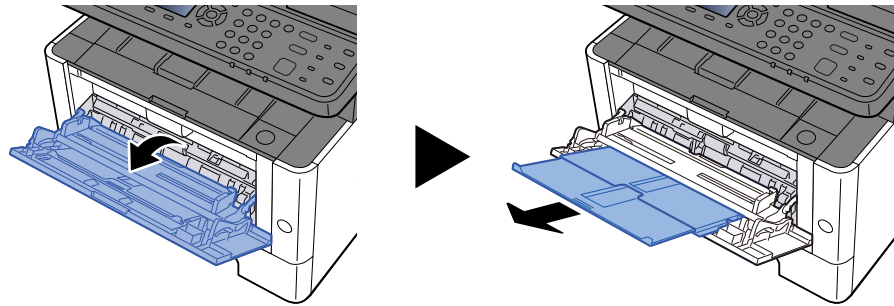

2 Adjust the multipurpose tray size.

Paper sizes are marked on the multipurpose tray.

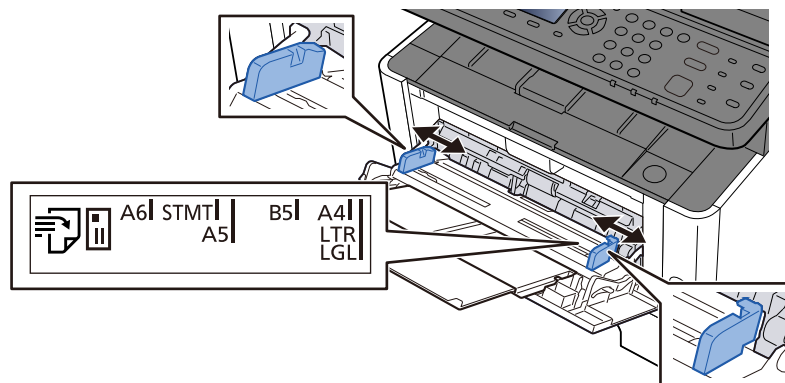

3 Load paper

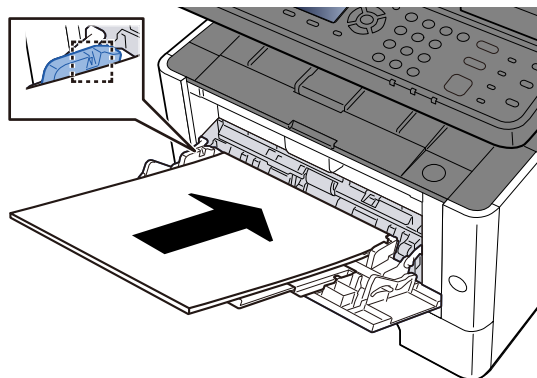

Insert the paper along the paper width guides into the tray until it stops.

After removing new paper from its packaging, fan the paper before loading it in the multipurpose tray.

➔ [Precaution for Loading Paper \(page 131\)](#)

✔ IMPORTANT

- When loading the paper, keep the print side facing up.
- Curled paper must be uncurled before use.
- When loading paper into the multipurpose tray, check that there is no paper left over in the tray from a previous job before loading the paper. If there is just a small amount of paper left over in

the multipurpose tray and you want to add more, first remove the left-over paper from the tray and include it with the new paper before loading the paper back into the tray.

- If there is a gap between the paper and the paper width guides, readjust the guides to fit the paper in order to prevent skewed feeding and paper jams.
- Ensure that the loaded paper does not exceed the load limits.

When you load envelopes or cardstock in the multipurpose tray, load the paper with the print side facing up. For the procedure for printing, refer to the Printer Driver User Guide.

➔ **Printer Driver User Guide**

Example: When printing the address.

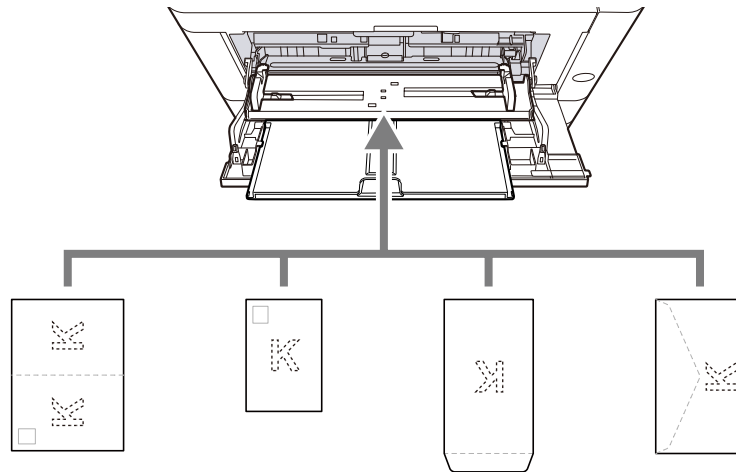

- Oufuku hagaki (Return postcard)
- Hagaki (Cardstock)
- Vertical envelope (open opening)
- Horizontal envelope (close opening)

✔ **IMPORTANT**

- Use unfolded Oufuku hagaki (Return postcard).
- How to load envelopes (orientation and facing) will differ depending on the type of envelope. Be sure to load it in correctly, otherwise printing may be done in the wrong direction or on the wrong face.

💡 **NOTE**

When you load envelopes in the multipurpose tray, select the envelope type by referring to the following:

➔ [\[MF Tray Set.\] \(page 435\)](#)

4 Specify the type of paper loaded in the multipurpose tray using the operation panel.

➔ [Specifying Paper Size and Media Type \(page 140\)](#)

Is the paper damp?

Replace the paper with new paper.

➔ [Precaution for Loading Paper \(page 131\)](#)

Printouts are curled



Is the paper loaded correctly?

Load the paper correctly.

When loading paper in a cassette

- 1 Pull the cassette completely out of the machine.**

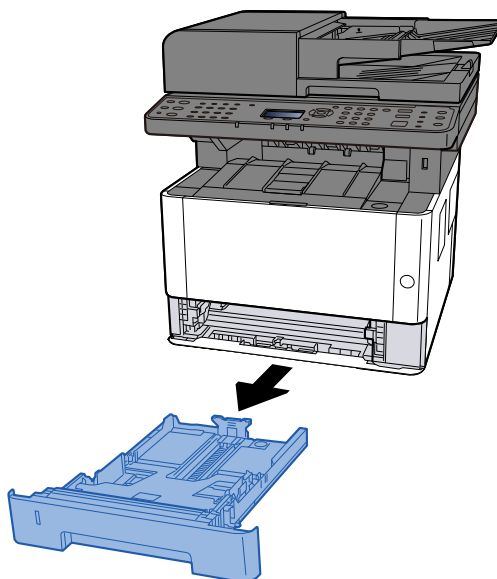

NOTE

If the baseplate is rising, push the baseplate until it locks.

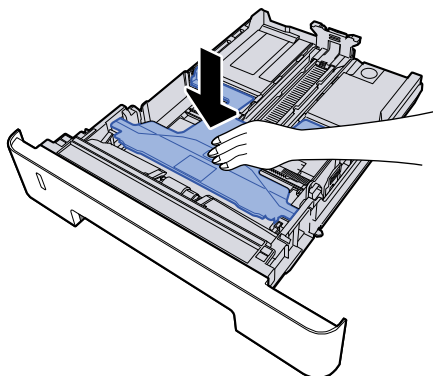

2 Adjust the cassette size.

- 1 Adjust the paper length guide to the paper size required. Press the paper length adjusting tab and slide the guides to the paper size required.

Paper sizes are marked on the cassette.

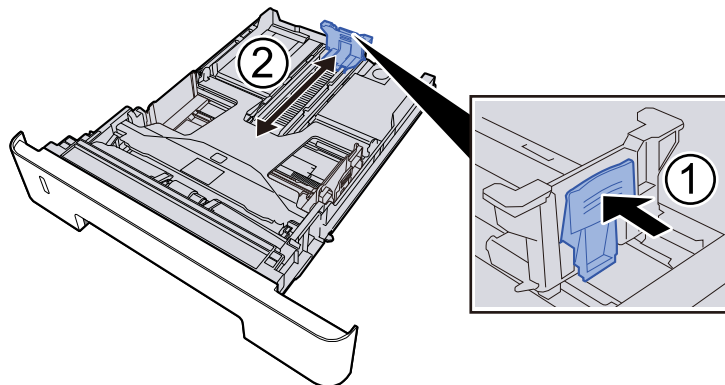

✔ IMPORTANT

When using Folio, Oficio II, or Legal

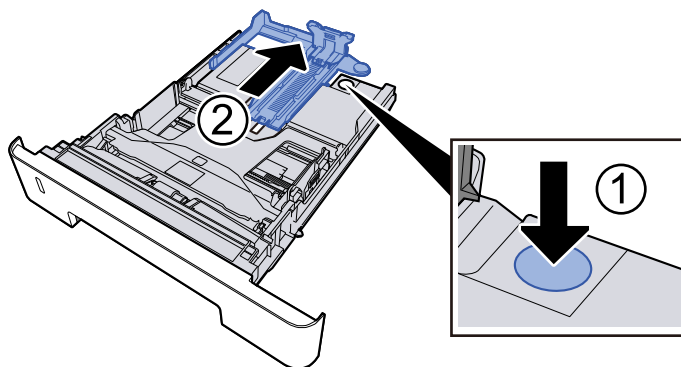

- 2 Adjust the position of the paper width guides located on the left and right sides of the cassette. Press the paper width adjusting tab and slide the guides to the paper size required.

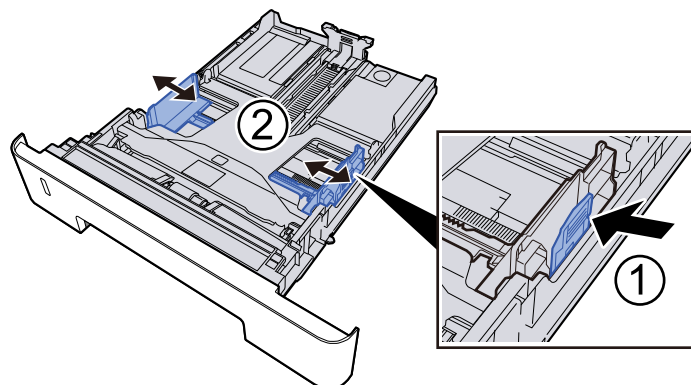

3 Load paper

- 1 Fan the paper, then tap it on a level surface to avoid paper jams or skewed printing.
- 2 Load the paper in the cassette.

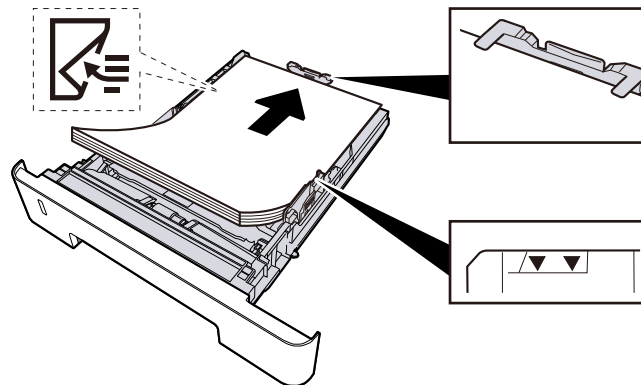

✔ IMPORTANT

- Load the paper with the print side facing down.
 - After removing new paper from its packaging, fan out the paper before loading it in the cassettes.
 - ➔ [Precaution for Loading Paper \(page 131\)](#)
 - Before loading the paper, be sure that it is not curled or folded. Paper that is curled or folded may cause paper jams.
 - Ensure that the loaded paper does not exceed the level indicator.
 - If paper is loaded without adjusting the paper length guide and paper width guide, the paper may skew or become jammed.
-

4 Gently push the cassette back in.

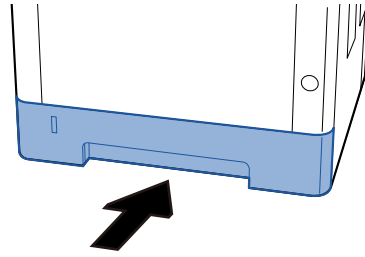

✔ IMPORTANT

Push all cassettes all the way in. If they are not pushed all the way in, they may cause a jam.

💡 NOTE

There is a paper gauge on the right side of the front of the cassette. The display changes up and down to match the remaining amount of paper.

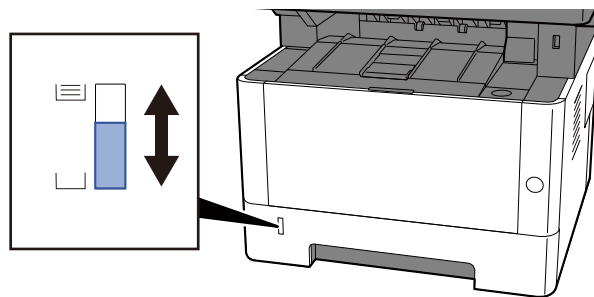

Remove the paper from the cassette once if there is no improvement, turn it over and reload it, or change the loading direction by rotating the paper 180 degrees.

➔ [Precaution for Loading Paper \(page 131\)](#)

When loading paper in the multipurpose tray

1 Open the multipurpose tray.

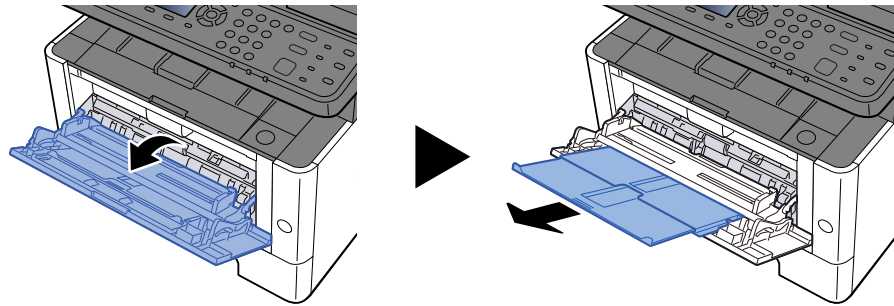

2 Adjust the multipurpose tray size.

Paper sizes are marked on the multipurpose tray.

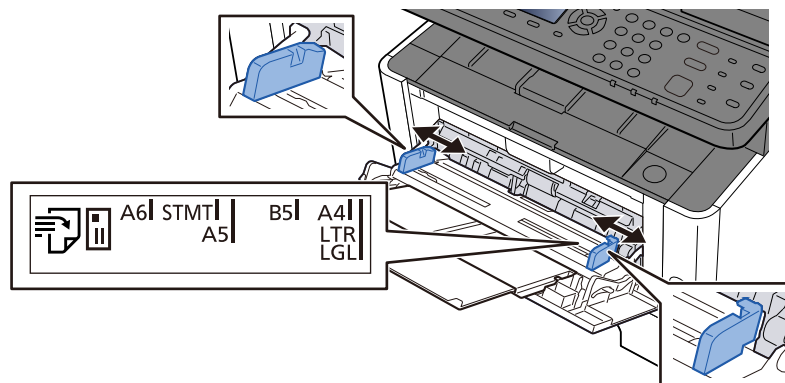

3 Load paper

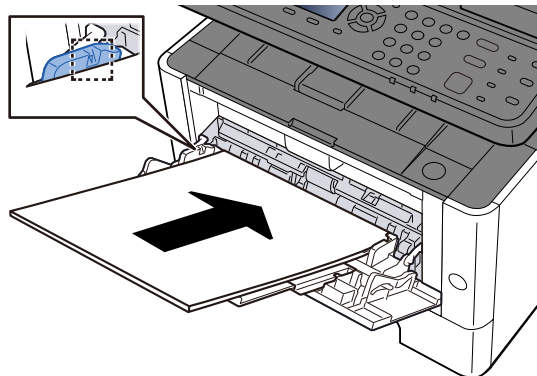

Insert the paper along the paper width guides into the tray until it stops.

After removing new paper from its packaging, fan the paper before loading it in the multipurpose tray.

➔ [Precaution for Loading Paper \(page 131\)](#)

✔ IMPORTANT

- When loading the paper, keep the print side facing up.
- Curled paper must be uncurled before use.
- When loading paper into the multipurpose tray, check that there is no paper left over in the tray from a previous job before loading the paper. If there is just a small amount of paper left over in

the multipurpose tray and you want to add more, first remove the left-over paper from the tray and include it with the new paper before loading the paper back into the tray.

- If there is a gap between the paper and the paper width guides, readjust the guides to fit the paper in order to prevent skewed feeding and paper jams.
- Ensure that the loaded paper does not exceed the load limits.

When you load envelopes or cardstock in the multipurpose tray, load the paper with the print side facing up. For the procedure for printing, refer to the Printer Driver User Guide.

➔ **Printer Driver User Guide**

Example: When printing the address.

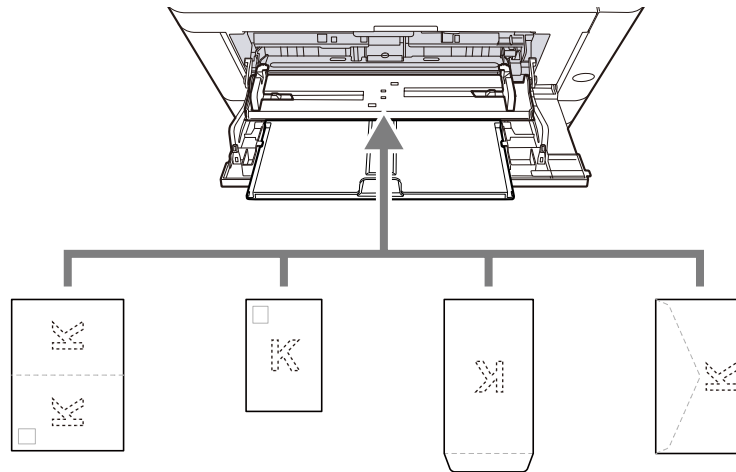

- Oufuku hagaki (Return postcard)
- Hagaki (Cardstock)
- Vertical envelope (open opening)
- Horizontal envelope (close opening)

✔ **IMPORTANT**

- Use unfolded Oufuku hagaki (Return postcard).
- How to load envelopes (orientation and facing) will differ depending on the type of envelope. Be sure to load it in correctly, otherwise printing may be done in the wrong direction or on the wrong face.

💡 **NOTE**

When you load envelopes in the multipurpose tray, select the envelope type by referring to the following:

➔ [\[MF Tray Set.\] \(page 435\)](#)

4 Specify the type of paper loaded in the multipurpose tray using the operation panel.

➔ [Specifying Paper Size and Media Type \(page 140\)](#)

Is the paper damp?

Replace the paper with new paper.

Printer driver cannot be installed

Is the driver installed with the host name while Wi-Fi or Wi-Fi Direct function is available?

Specify the IP address instead of the host name.

→ [Installing Software \(page 86\)](#)

Is Level 3 selected in Security Quick Setup?

- 1 Acquire a root certificate for SSL communication from a trusted root certification authority. In Command Center RX, click [Security Settings] > [Certificates], and register the root certificate in [Root Certificate 1] to [Root Certificate 5].**
- 2 After installing the certificate, restart the PC.**
- 3 In Command Center RX, click [Network Settings] > [Protocols], and in [Other Protocols], set "SNMPv3" to [On].**
- 4 In Command Center RX, click [Management Settings] > [SNMP], and set "SNMPv3".**
- 5 Access [Control Panel], and click [Devices and Printers], [Add a printer], [The printer that I want isn't listed].**
- 6 Check [Select a shared printer by name] and enter the address of the printer.
E.g.: https://hostname:443/printers/lp1**
- 7 Select the desired printer and specify the printer driver.**

Cannot start printing

Is the machine plugged in?

Plug the power cord into an AC outlet.

Is the power turned on?

Turn the power switch on.

1 Turn the power switch on.

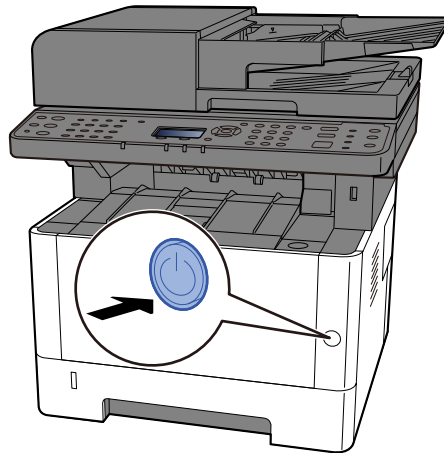

 **IMPORTANT**

Wait more than 5 seconds, and then turn on the power switch.

Are the USB cable and network cable connected?

Make sure to connect the USB cable and network cable securely.

Connect the network cable

✔ IMPORTANT

If the power is on, turn the power switch off.

➔ [Power off \(page 56\)](#)

1 Connect the cable to the machine.

- 1 Connect the LAN cable to the network interface connector.

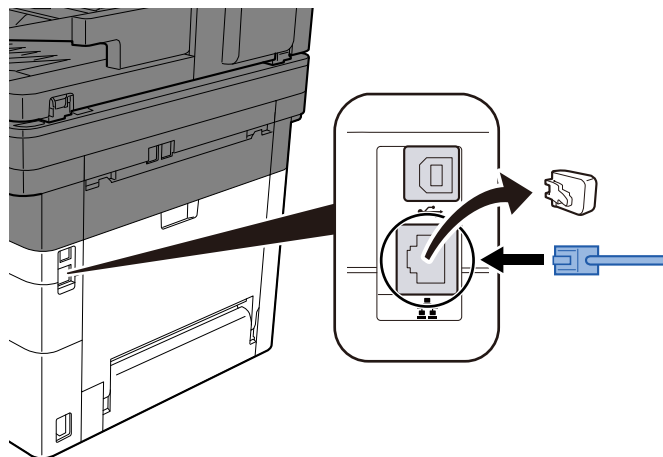

- 2 Connect the other end of the cable to the hub.

2 Power on the machine and configure the network.

➔ [Network Setup \(page 69\)](#)

Connect a USB cable to the machine.

✔ IMPORTANT

If the power is on, turn the power switch off.

➔ [Power off \(page 56\)](#)

1 Connect the cable to the machine.

- 1 Connect the USB cable to the USB interface connector.

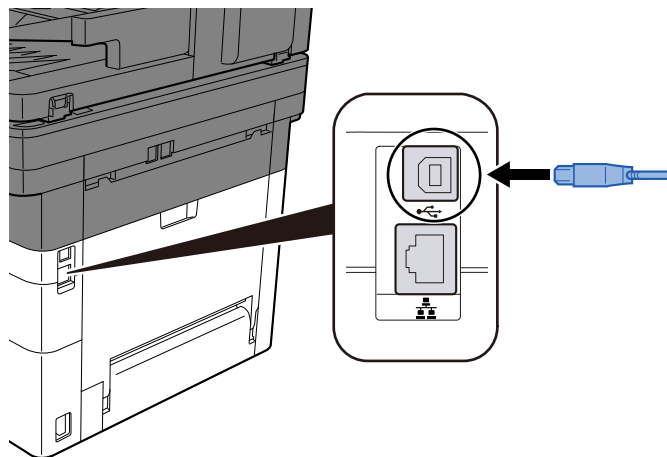

- 2 Connect the other end of the cable to the PC.

2 Power on the machine.

Is the print job paused?

Resume printing.

1 Display the screen

- 1 Select the [Status/Job Cancel] key.

2 Select [Pause].

Printing is paused.

When resuming the printing of jobs that have been paused, select [Resume].

NOTE

Selecting a function key such as the [Back] key or the [Copy] key while the job is paused will [Resume paused jobs. Are you sure?] is displayed. Select [Yes] and select the [OK] key to restart the job and display the following screen. If you select [No] and select the [OK] key, the job remains paused and the following screen appears.

Are there a mixture of inaccessible addresses?

If you have configured wired and Wi-Fi networks with name resolution, you may have a mix of IP addresses (private addresses) on the other inaccessible network.

IMPORTANT

Only one host name and one domain name can be used on this machine. Please consider this limitation when setting the network operation.

1 [System Menu] key > [▲] [▼] keys > [System/Network] > [OK] key > [▲] [▼] keys > [Primary Network] > [OK] key

Select Wi-Fi or Wired as the network to use without restrictions.

➔ [\[Primary Network\] \(page 404\)](#)

2 [System Menu] key > [▲] [▼] keys > [System/Network] > [OK] key > [▲] [▼] keys > [Network Setting] > [OK] key > [▲] [▼] keys > [ProtocolSettings] > [OK] key

Please [Enable] either [Wired Network] or [Wi-Fi] and [Disable] the other.

➔ [\[ProtocolSettings\] \(page 394\)](#)

3 In Command Center RX, change the settings for name resolution of NetBEUI, DNS, etc., or change the network environment settings.

➔ [Command Center RX User Guide](#)

Cannot print with USB drive / Does not recognize USB drive

Is the USB drive connected to the machine firmly?

Connect the USB drive firmly to the machine.

Are USB host settings set to [Block]?

1 Change the USB host setting to [Unblock]

[System Menu] key > [▲] [▼] keys > [System/Network] > [OK] key > [▲] [▼] keys > [I/F Block Set.] > [OK] key

➔ [\[I/F Block Set.\] \(page 405\)](#)

Is the USB drive broken?

Use another USB drive.

While [Auto-IP] is already set to [On], the IP address is not assigned automatically

Is a value other than "0.0.0.0" entered for the link local address of TCP/IP(v4)?

1 Enter "0.0.0.0" in IP Address of TCP/IP(v4).

1 [System Menu/Counter] key > [▲][▼] keys > [System/Network] > [OK] key > [▲][▼] key > [Network Setting] > [OK] key > [▲][▼] key > [Wired Netwk. Set] > [OK] key > [▲][▼] keys > [TCP/IP Settings] > [OK] key > [▲][▼] keys > [IPv4 Setting] > [OK] key

2 Enter "0.0.0.0" in IP Address.

➔ [TCP/IP \(IPv4\) setting \(page 69\)](#)

Cannot send via SMB

Is the network cable connected?

Connect the cable to the Machine and HUB securely.

1 Connect the cable to the machine.

- 1 Connect the LAN cable to the network interface connector.

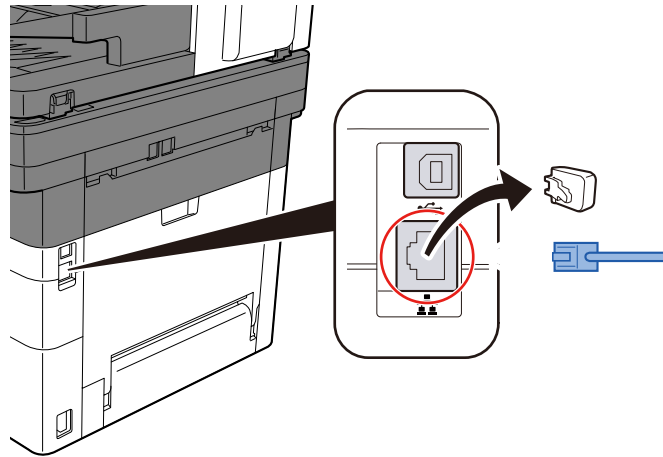

Are the network settings on the machine configured correctly?

Check that TCP/IP is [On], and IPv4 or IPv6 is configured in accordance with the usage environment.

➔ [\[TCP/IP Settings\] \(page 385\)](#)

Is SMB protocol configured?

1 Set the SMB protocol settings to On.

[System Menu/Counter] key > [▲] [▼] keys > [System/Network] > [OK] key > [▲] [▼] keys > [Network Setting] > [OK] key > [▲] [▼] keys > [ProtocolSettings] > [OK] key > [▲] [▼] keys > [SMB] > [OK] key > [▲] [▼] keys > [On] > [OK] key

Are the host name, folder path, login user name, and login password of the destination computer correct?

1 Select the [Send] key

2 [▲] [▼] keys > [SMB] > [OK] key

3 Enter the destination details.

Enter each item and select the [OK] key.

 **NOTE**

When selecting On for "Check New Dest.", the re-entering screen for the destination information appears.

➔ [Re-entering the New Destination \(page 257\)](#)

The table below explains the items to be entered.

Item	Description
Host Name Host Name	Computer name Enter "Host Name" or "IP Address". To enter the IPv6 address, enclose the IPv6 address in brackets []. Limited character count: 256 characters or less Example: [2001:db8:a0b:12f0::10] (Example: [2001:db8:a0b:12f0::10])
Path	Share name Limited character count: 260 characters or less For example: scannerdata If saving in a folder in the shared folder: share name\folder name in shared folder
Login User Name	<ul style="list-style-type: none"> • If the computer name and domain name are the same User Name For example: james.smith. • If the computer name and domain name are different Domain name\User name For example: abcdnet\james.smith Limited character count: 64 characters or less <hr/> <p> NOTE</p> When transmitting using the wireless network, only alphanumeric characters are allowed. Also, if the computer name and domain name are different because "\" is not available, use @ to enter the user name in the following format: User name@Domain name (Example: james.smith@abcdnet) <hr/>
Login Password	Logon password. Limited character count: 128 characters or less Upper case and lower case letters are distinguished (case sensitive).

A host name can also specify a port number. Enter the following format separated by a colon.

"Host name:Port number" or "IP Address:Port number". To enter an IPv6 address, enclose the IPv6 address in brackets [].

(Example: [2001:db8:a0b:12f0::10]:445) The default port number is 445 if not specified.

Are the folder sharing settings configured correctly?

Check the sharing settings and access permissions in the folder properties.

- 1 Right-click the shared folder and click [Properties] → [Security], in that order.**
- 2 Select a user and make sure the user you entered in the group name or user name field is displayed**
- 3 Make sure that checkmarks appear on the [Allows] checkbox for "Modify" and "Read & Execute".**
- 4 Click the [Close] button.**
→ [Create a shared folder and make a note of the shared folder name \(page 145\)](#)

Is the selected interface selected as the Primary Network?

Make sure the selected interface is selected as the Primary Network.

- 1 [System Menu/Counter] key > [▲] [▼] keys > [System/Network] > [OK] key > [▲] [▼] keys > [Primary Network] > [OK] key >**
- 2 Specify the host name or IP address of the interface selected as the Primary Network, or reconfigure it to the interface you want to use.**
For example, if you selected Wi-Fi as your preferred network, specify the host name or IP address of your wireless network.

Are the exception settings for Windows Firewall configured correctly?

Make sure that the exception settings for Windows Firewall are configured correctly.

- 1 Select [Windows System] → [Control Panel] → [System and Security] → [Allow an app through Windows Firewall] from the desktop charm, in that order.**
- 2 Make sure that checkmarks appear on the checkbox for [File and Printer Sharing]**
- 3 Return to screen [System and Security] and select [Check Firewall Status] for Windows Defender Firewall.**
- 4 Click [Advanced Setting] → [Inbound Rules], in that order.**
- 5 Confirm that the registered exception settings (rules) are displayed in the list.**
→ [Configuring Windows Firewall \(page 150\)](#)

Are the time settings of the machine, domain server, and data destination PC all synchronized?

Synchronize the time settings of the machine domain server, and the data destination PC.

Is "Send error." displayed on the screen?

For details, refer to the following:

➔ ["Send error." is displayed \(page 663\)](#)

Cannot send via email

Is the email send size limited in the SMTP server registered in this machine?

Check email sending size in Command Center RX.

- 1** Launch your Web browser.
- 2** In the address or location bar, enter the machine's IP address or the host name.
- 3** Log in with administrator privileges.
- 4** Click [Functions] in the [E-mail] menu
- 5** Check whether a restriction value is entered in [E-mail Size Limit] of "E-mail Send Settings", and change it as necessary.
- 6** Click [Submit].
 - ➔ [SMTP and E-mail Settings \(page 116\)](#)

The machine is emitting steam in the area around the paper ejection slot

Is the temperature in the room where the machine is running low? Or was damp paper used?

Depending on the machine's printing environment and the condition of the paper, the moist contained in the paper may evaporate due to the heat generated during printing, and the water vapor emitted may look like smoke.

There is no problem, and you can continue printing. If the steam concerns you, raise the room temperature or replace the paper with a new dryer paper.

Even after replacing the toner container, the message to replace the toner container does not disappear

Corrective Actions

Make sure the rear cover, and other covers are closed.

Cannot find the machine with WSD

Are you searching for this machine by specifying the IP address or host name?

For security reasons, protocol is set to off, and therefore you cannot search by IP address or host name.

Printed Image Trouble

Printouts are totally too light

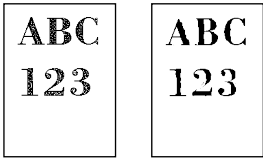

Is the paper damp?

Replace the paper with new paper.

Is the media type set correctly?

Check if the media type setting is correct.

- 1** [System Menu/Counter] key > [▲] [▼] key > [Common Settings] > [OK] key > [▲] [▼] key > [Orig./Paper Set.] > [OK] key > [▲] [▼] key > [Cassette 1 Set.] - [Cassette 3 Set.]> [OK] key > [▲] [▼] key > [Cassette 1 Type] - [Cassette 3 Type]> [OK] key
- 2** Check the weight (paper thickness) for the paper type and change it to the correct value

Have you changed the density?

Select appropriate density level.

- 1** Set the concentration in the range of[-4] to [+4]

➔ [Density \(page 294\)](#)



NOTE

To print with the same density all the time, select from the [Adjust/Maint.]

[System Menu/Counter] key > [▲] [▼] key > [Adjust/Maint.] > [OK] key > [▲] [▼] key > [Copy Denst. Adj.] or [Print Density] > [OK] key

➔ [Copy Denst. Adj. \(page 478\)](#)

➔ [\[Copy Denst. Adj.\] \(page 478\)](#)

Have you set EcoPrint?

Set to [Off].

- 1 [System Menu/Counter] key > [▲] [▼] keys > [Printer] > [OK] key > [▲] [▼] keys > [EcoPrint] > [OK] key
- 2 [▲] [▼] keys > [Off] > [OK] key

Drum refresh needs to be performed.

1 Display the screen

- 1 [System Menu/Counter] key > [▲] [▼] keys > [Adjust/Maint.] > [OK] key > [▲] [▼] keys > [Service Setting] > [OK] key

2 Perform the Drum Refresh.

- 1 [▲] [▼] keys > [Drum Refresh] > [OK] key > [Yes]

Drum Refresh begins.

Are the developer unit and drum unit installed properly?

1 Install the developing unit and drum unit correctly.

- ➔ [Clean the inside of the main unit \(page 543\)](#)

White background parts of the image appear to have a slight overall grey coloration

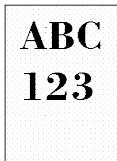

Have you changed the density?

Select appropriate density level.

1 Set the concentration in the range of[-4] to [+4]

→ [Density \(page 294\)](#)



NOTE

To print with the same density all the time, select from the [Adjust/Maint.]

[System Menu/Counter] key > [▲] [▼] keys > [Adjust/Maint.] > [OK] key > [▲] [▼] keys > [Copy Denst. Adj.] > [OK] key

→ [\[Print Density\] \(page 479\)](#)

→ [\[Copy Denst. Adj.\] \(page 478\)](#)

Drum refresh needs to be performed.

1 Display the screen

- 1 Select the [System Menu/Counter] key > [▲] [▼] keys > [Adjust/Maint.] > [OK] key > [▲] [▼] keys > [Service Setting] > [OK] key > [▲] [▼] keys > [Drum Refresh] > [OK] key.

2 Run [Drum Refresh]

- 1 Select [Yes].
[Drum Refresh] begins.

Increase the value of MC.

1 Display the screen

- 1 [System Menu/Counter] key > [▲] [▼] keys > [Adjust/Maint.] > [OK] key > [▲] [▼] keys > [Service Setting] > [OK] key

2 Select a value larger than the current value by selecting [▲] [▼] keys > [MC] > [OK] > [▲] [▼] key.

3 Print and check the image quality

Increase the setting value until it improves.



NOTE

If no improvement is seen, return to the original settings.

Copies have a moire pattern (dots grouped together in patterns and not aligned uniformly)

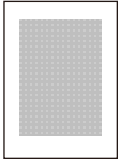

Is it an original with a photo printed on it?

Check the content structure of the original and change it to an appropriate image quality.

1 Select a [Original Image] for each function

2 Select [Photo].

→ [Original Image \(page 295\)](#)

Adjusts the sharpness of image outlines.

1 Select a [Sharpness] for each function

2 Set in the range of [-1] to [-3]

Set [DP Read Action] to [Quality Priority].

1 Display the screen

1 [System Menu/Counter] key > [▲] [▼] keys > [Copy] > [OK] key > [▲] [▼] keys > [DP Read Action] > [OK] key

2 Configure the settings

1 [▲] [▼] keys > [Quality Priority] > [OK] key

Texts are not clearly printed

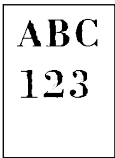

Have you selected appropriate image quality for the original?

Check the content structure of the original and change it to an appropriate image quality.

- 1 Select a [Original Image] for each function**
- 2 Select the image quality that matches the type of the original**
→ [Original Image \(page 295\)](#)

Adjusts the sharpness of image outlines.

- 1 Select a [Sharpness] for each function**
- 2 Set in the range of [-1] to [-3]**

Black or color dots appear on the white background

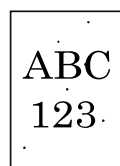

Is the original holder or the platen dirty?

Wipe the inside of the document processor and the platen with a soft cloth dampened with alcohol or mild detergent.

✔ IMPORTANT

Do not use thinner or other organic solvents.

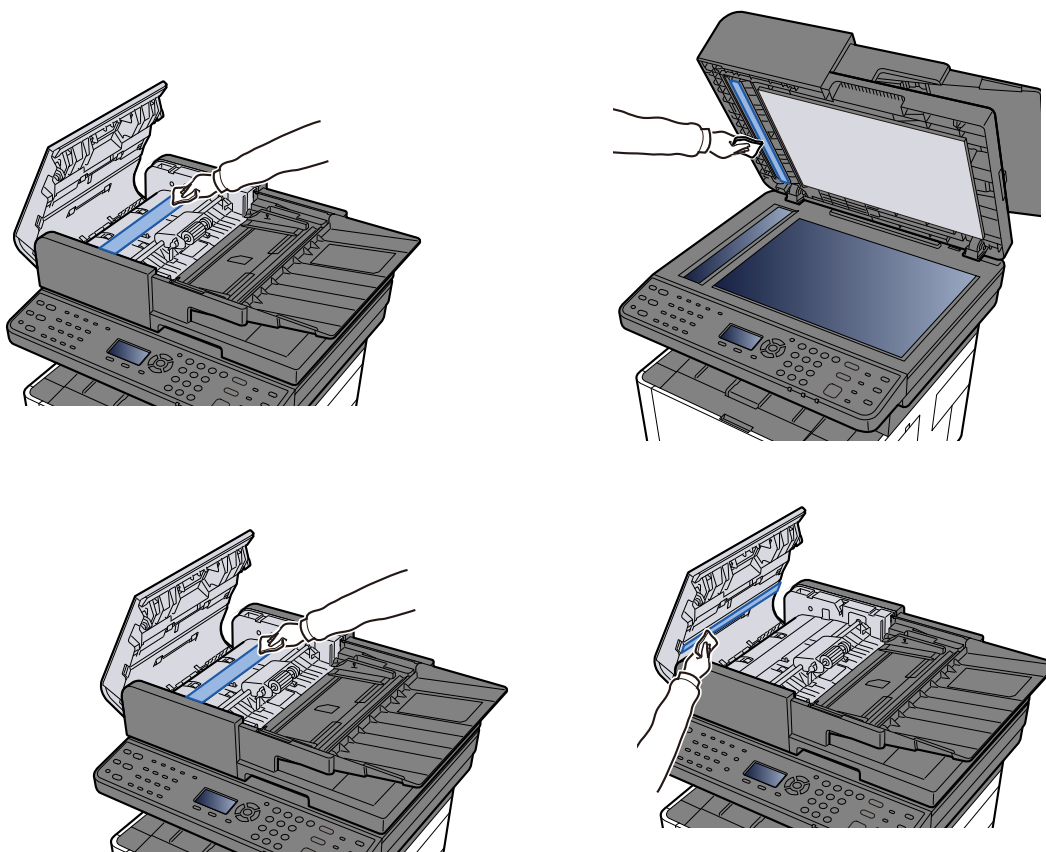

Drum refresh needs to be performed.

1 Display the screen

- 1 [System Menu/Counter] key > [▲] [▼] keys > [Adjust/Maint.] > [OK] key > [▲] [▼] keys > [Service Setting] > [OK] key

2 Perform the Drum Refresh.

- 1 [▲] [▼] keys > [Drum Refresh] > [Yes]
Drum Refresh begins.

Increase the value of MC.

1 Display the screen

- 1 [System Menu/Counter] key > [▲] [▼] keys > [Adjust/Maint.] > [OK] key > [▲] [▼] keys > [Service Setting] > [OK] key

2 Select a value larger than the current value by selecting [▲] [▼] keys > [MC] > [OK] > [▲] [▼] key.

3 Print and check the image quality

Increase the setting value until it improves.



NOTE

If there is no improvement, return to the original settings.

Printed images are fuzzy or cut off

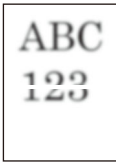

Are you using the machine in a place with high humidity or drastic temperature and humidity fluctuations?

Use the machine in an environment with appropriate humidity.

Drum refresh needs to be performed.

1 Display the screen

- 1 [System Menu/Counter] key > [▲] [▼] keys > [Adjust/Maint.] > [OK] key > [▲] [▼] keys > [Service Setting] > [OK] key

2 Perform the Drum Refresh.

- 1 [▲] [▼] keys > [Drum Refresh] > [Yes]

Drum Refresh begins.

Printed images are shifted



Is the original set correctly?

- When setting the original on the platen, make sure to align the original with the original size indicator plate.
➔ [Placing Originals on the Platen \(page 221\)](#)
- When loading the original in the document processor, make sure to align the original width guides before loading the original.
➔ [Loading Originals in the document processor \(page 223\)](#)

Is the paper loaded correctly?

Adjust the paper length guide and width guide of the cassette to fit the paper size.

- ➔ [Loading in the Cassettes \(page 133\)](#)

Irregular horizontal lines appear in the image

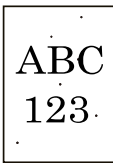

MC needs to be performed.

1 Display the screen

- 1 [Menu] key > [▲] [▼] keys > [Adjust/Maint.] > [OK] key > [▲] [▼] keys > [Service Setting] > [OK] key > [▲] [▼] keys > [MC] > [OK] key

2 Execute

- 1 Select [Yes].

Increase the setting value. When making adjustments, increase the current value by one level at a time. If the effect does not appear even after increasing the setting by one level, increase the setting by one more level. If the effect does not appear, reduce the original value by one level at a time. If the effect does not appear even after reducing the value by one level, try reducing the value by one more level. If the effect still does not appear, please change the value back to its original value.

The usage environment is at a high altitude of 1000m or higher, and irregular horizontal white lines appear on the image.



- 1** Select [System Menu/Counter] key > [▲] [▼] keys > [Adjust/Maint.] > [OK] key > [▲] [▼] keys > [Service Setting] > [OK] key > [▲] [▼] keys > [Altitude Adj.] > [OK] key and set the altitude one level higher than the current setting.

The usage environment is at a high altitude of 1000m or higher, and color dots appear in the image.



- 1** Select [System Menu/Counter] key > [▲] [▼] keys > [Adjust/Maint.] > [OK] key > [▲] [▼] keys > [Service Setting] > [OK] key > [▲] [▼] keys > [Altitude Adj.] > [OK] key and set the altitude one level higher than the current setting.

Printed images have vertical lines



Is the slit glass dirty?

When using the document processor, clean the slit glass surface and the reading guide with the dry cloth.

✔ IMPORTANT

Do not use water, soap or solvents for cleaning.

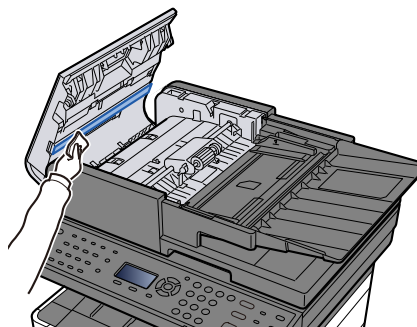
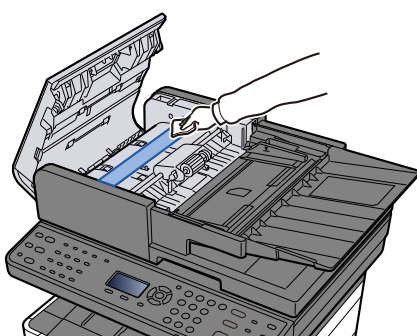
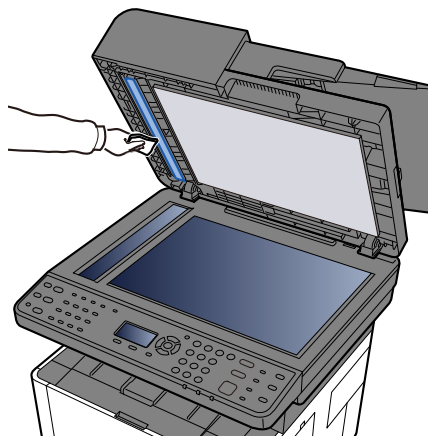
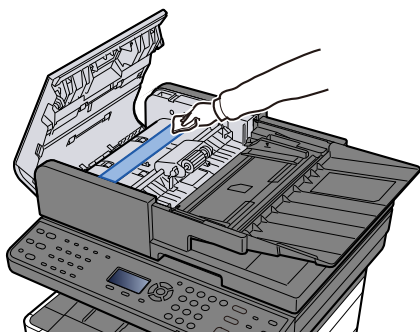

Clean the charger inside the main unit.

1 Open the Front cover.

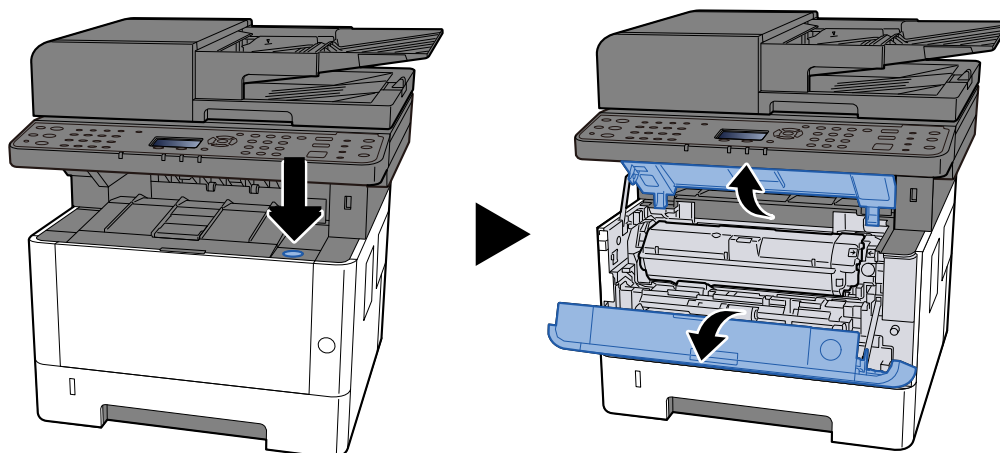

2 Remove Developer unit.

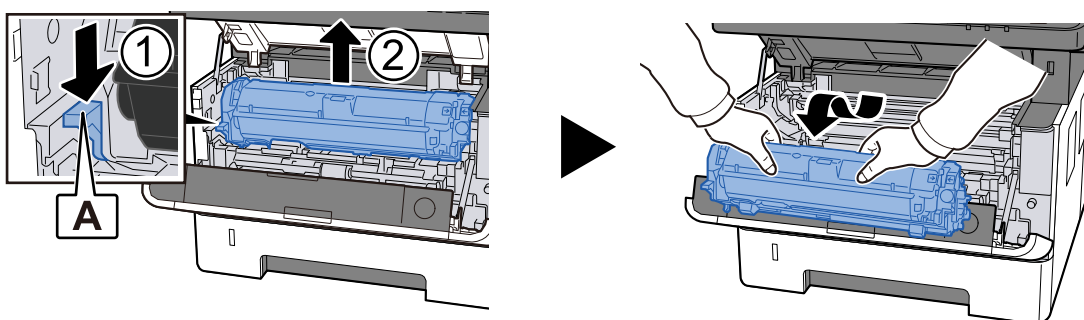

NOTE

Do not touch the developing roller or subject it to impact. Print quality will deteriorate.

3 Place the removed Developer unit on a clean, level surface.

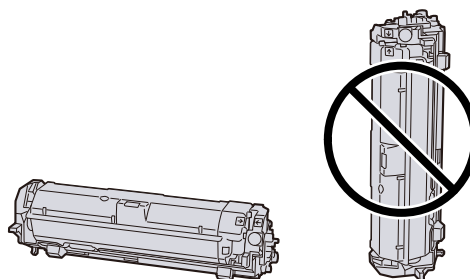

NOTE

Do not stand the Developer unit upright.

4 Remove Drum unit.

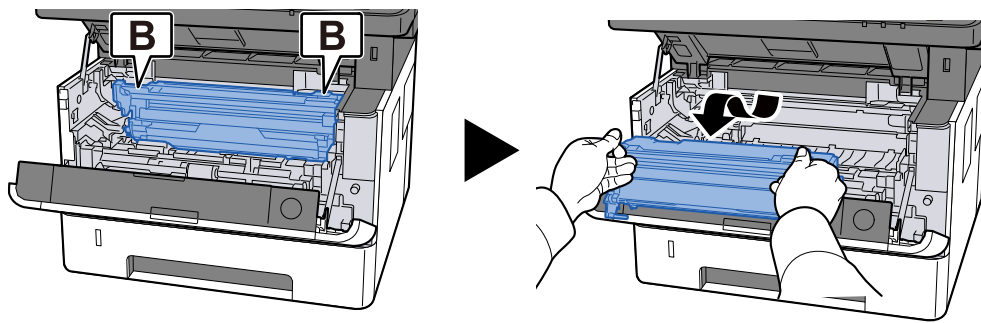

NOTE

Do not touch the drum part or subject it to impact. Also, if exposed to direct sunlight or strong light, print quality will deteriorate.

5 Place the removed Drum unit on a clean, level surface.

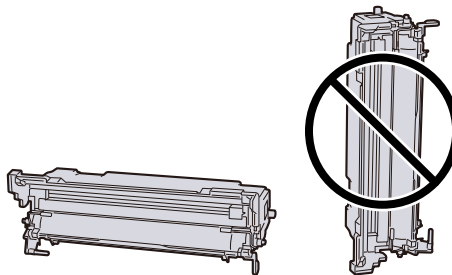

NOTE

Do not stand the Drum unit upright.

6 Wipe away the paper dust and dirt on Registration roller (metal) using a soft, dry cloth.

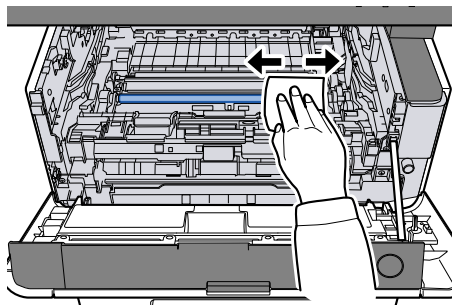

7 Slide the upper charger cleaner knob of the Drum unit to the left and right two or three times.

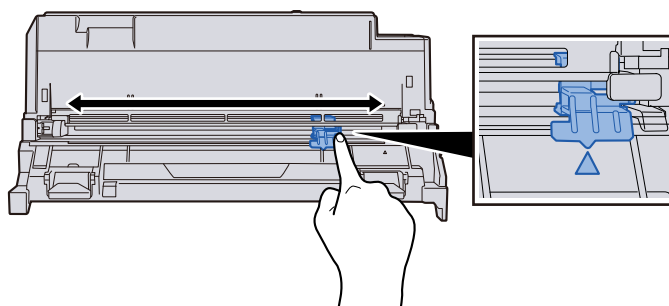

 **NOTE**

- When cleaning the charger wire for the first time, remove the tape that secures the charger cleaner knob.
- After cleaning, return the charger cleaner knob to its original position.

8 Return the Drum unit.

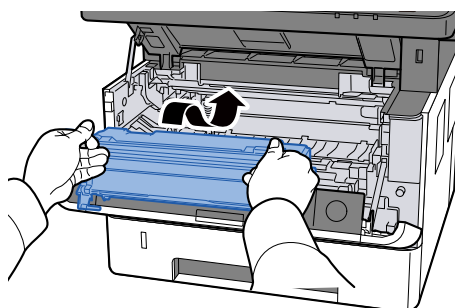

9 Return the Developer unit.

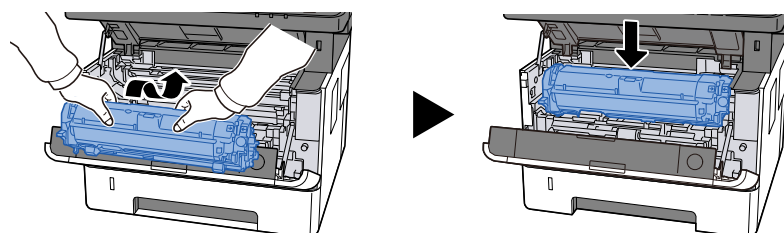

10 Close the Front cover.

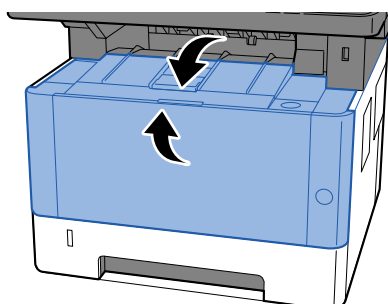

Dirt on the top edge or back of the paper

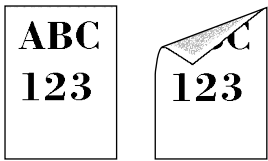

Is the inside of the machine dirty?

To maintain optimum print quality, it is also recommended that the inside of the machine be cleaned when the toner container is replaced and when vertical streaks appear.

1 Open the top cover.

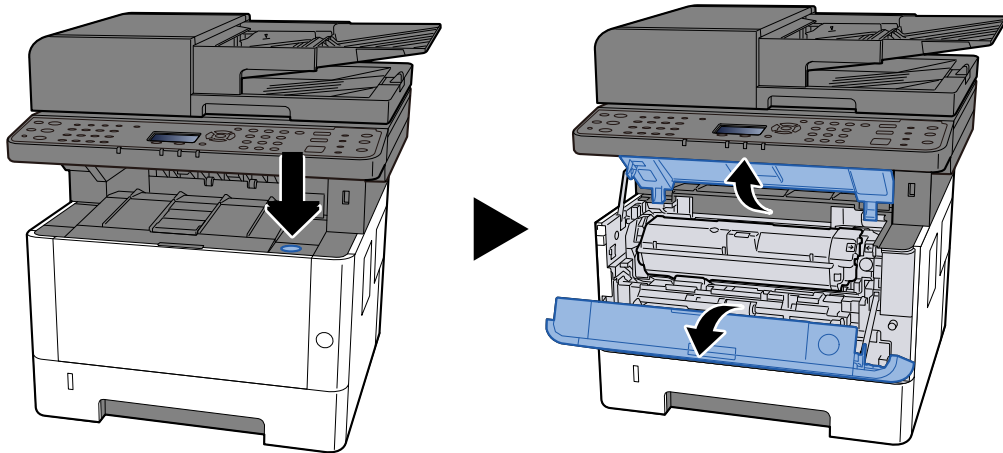

2 Remove Developer unit.

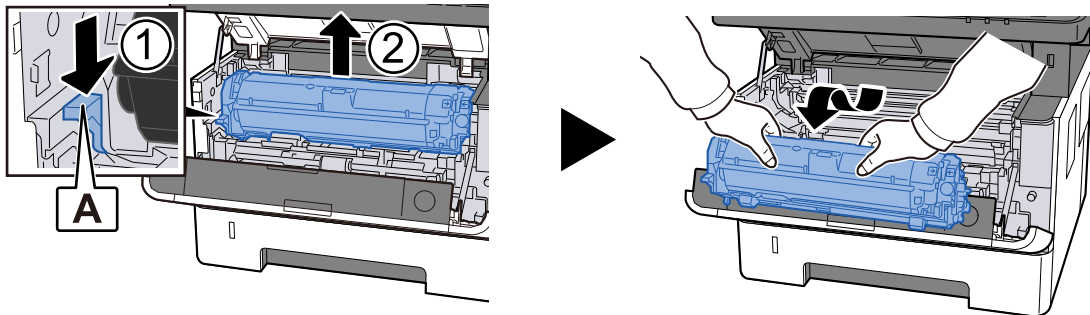

✓ IMPORTANT

Do not touch the developing roller or subject it to impact. Print quality will deteriorate.

3 Place the removed Developer unit on a clean, level surface.

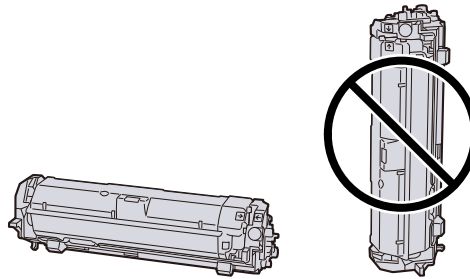

 **NOTE**

Do not stand the Developer unit upright.

4 Remove Drum unit

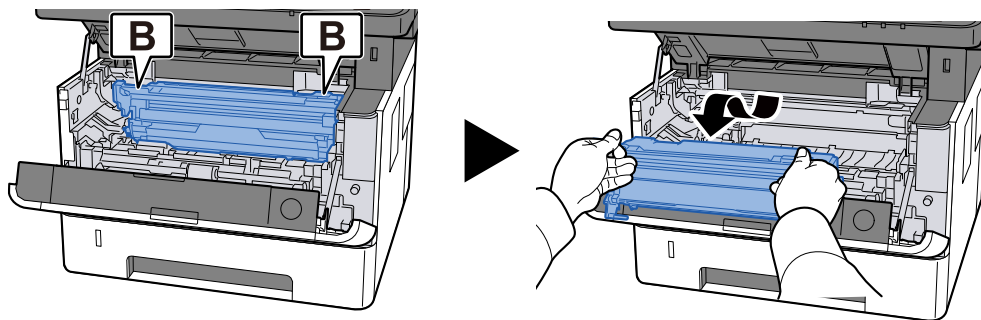

 **NOTE**

Do not touch the drum part or subject it to impact. Also, if exposed to direct sunlight or strong light, print quality will deteriorate.

5 Place the removed Drum unit on a clean, level surface.

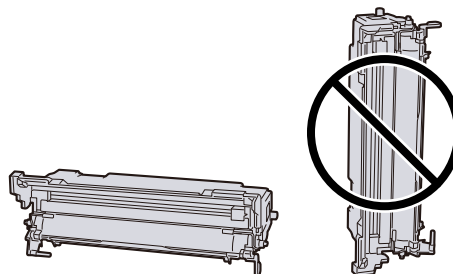

 **NOTE**

Do not stand the Drum unit upright.

- 6** Wipe away the paper dust and dirt on Registration roller (metal) using a soft, dry cloth.

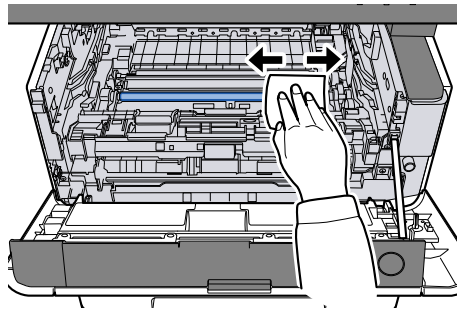

- 7** Slide the upper charger cleaner knob of the Drum unit to the left and right two or three times.

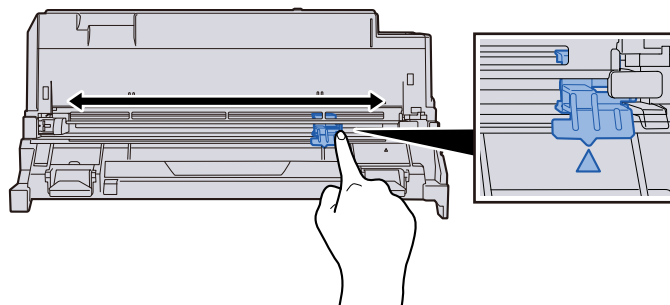

 **NOTE**

- When cleaning the charger wire for the first time, remove the tape that secures the charger cleaner knob.
- After cleaning, return the charger cleaner knob to its original position (CLEANER HOME POSITION)

- 8** Return the Drum unit.

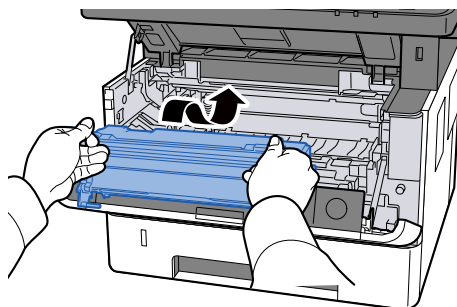

- 9** Return the Developer unit.

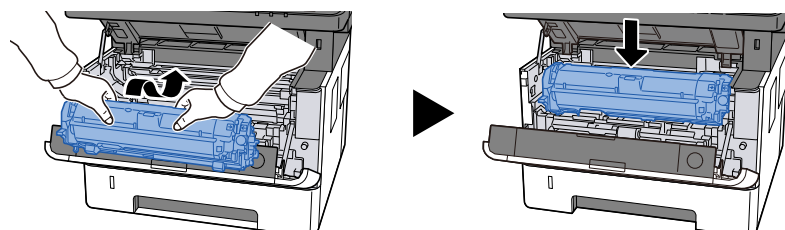

10 Close the top cover.

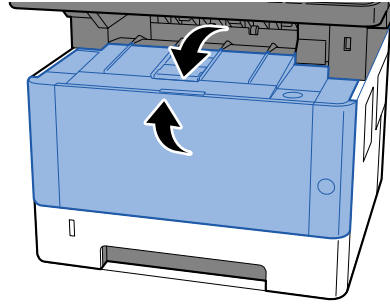

Part of the image is periodically faint or shows white lines



Is the Front Cover tightly closed?

Open the Front Cover and close it again.

Drum refresh needs to be performed.

1 Display the screen

- 1 [System Menu/Counter] key > [▲] [▼] keys > [Adjust/Maint.] > [OK] key > [▲] [▼] keys > [Service Setting] > [OK] key

2 Perform the Drum Refresh.

- 1 [▲] [▼] keys > [Adjust/Maint.] > [Yes]

Lower the MC value.

1 Display the screen

- 1 [System Menu/Counter] key > [▲] [▼] keys > [Adjust/Maint.] > [OK] key > [▲] [▼] keys > [Service Setting] > [OK] key

2 Select a value larger than the current value by selecting [▲] [▼] keys > [MC] > [OK] > [▲] [▼] keys.

3 Print and check the image quality

Increase the value until it improves.



NOTE

If no improvement is seen, return to the original value.

A lighter version of the previous image remains and is repeatedly printed



Is the media type set correctly?

Check if the media type setting is correct.

- 1 [System Menu/Counter] key > [▲] [▼] keys > [Common Settings] > [OK] key > [▲] [▼] keys > [Orig./Paper Set.] > [OK] key > [▲] [▼] keys > [Cassette 1 Set.] - [Cassette 3 Set.] > [OK] key > [▲] [▼] keys > [Cassette 1 Type] - [Cassette 3 Type] > [OK] key
- 2 Check the weight (paper thickness) for the paper type and change it to the correct value

Increase the value of MC.

- 1 Display the screen
 - 1 [System Menu/Counter] key > [▲] [▼] keys > [Adjust/Maint.] > [OK] key > [▲] [▼] keys > [Service Setting] > [OK] key
- 2 Select a value larger than the current value by selecting [▲] [▼] keys > [MC] > [OK] > [▲] [▼] key.
- 3 Print and check the image quality
Increase the setting value until it improves.



NOTE

If no improvement is seen, return to the original settings.

The print on the back page bleeds through



- 1 **[Function Menu] > [Prevent Bleed-thru] > [▲] [▼] keys > [On] > [OK] key**
-

 **NOTE**

You can also set the anti-reflection function in the following steps.

[System Menu/Counter] key > [▲] [▼] keys > [Common Settings] > [OK] key > [▲] [▼] keys > [Function Default] > [OK] key > [▼] key >

Remote Operation

This function enables the system administrator to explain how to operate the panel and troubleshoot to user, by accessing operation panel of the machine at remote using browser and VNC software.

Executing Remote Operation from Browser

The supported Browser is as follows. We recommend the latest version of browser to use Remote Operation.

- Google Chrome (Version 21.0 or later)
- Microsoft Edge
- Mozilla Firefox (Version 14.0 or later)
- Safari (Version 5.0 or later)

This section describes the procedure for performing remote operations from Command Center RX using Google Chrome.

 **NOTE**

To execute Remote Operation using other browsers, refer to the following:

➔ [Command Center RX User Guide](#)

1 Display the screen

- 1 [System Menu/Counter] key > [▲] [▼] keys > [System/Network] > [OK] key > [▲] [▼] keys > [Network Setting] > [OK] key > [▲] [▼] keys > [ProtocolSettings] > [OK] key

2 Set [EnhancedVNC or TLS]

➔ [\[ProtocolSettings\] \(page 394\)](#)

 **NOTE**

You can configure the protocol settings using Command Center RX.

➔ [Command Center RX User Guide](#)

3 Configure settings for remote operation.

- 1 [System Menu/Counter] key > [▲] [▼] keys > [System/Network] > [OK] key > [▲] [▼] keys > [Remote Operation] > [OK] key > [▲] [▼] keys > [Remote Ope. Set.] > [OK] key > [▲] [▼] keys > [On] > [OK] key
- 2 [▲] [▼] keys > [Use Restriction] > [OK] key > [▲] [▼] keys > [Off], select [Use Password] or [Admin. Only] > [OK] key

When you select [Use Password], enter the password in "Password" and "Confirm Password", then select [OK].

➔ [\[Remote Operation\] \(page 415\)](#)



NOTE

You can configure settings for remote operation using Command Center RX.

➔ [Command Center RX User Guide](#)

4 Restart the machine.

➔ [\[Restart\] \(page 409\)](#)

5 Start up the browser.

Specify https:// [Host name of this Machine] and start Command Center RX.

➔ [Accessing Command Center RX \(page 113\)](#)

6 [Device Information / Remote Operation] > [Remote Operation]

7 Click [Start].



NOTE

- If the user is logged in to the device, the permission confirmation screen will be displayed on the operation panel. Select [Yes].
- If pop-up blocking of the browser occurs during connection of the Remote Operation, select Always allow pop-ups from https:// [host name], and click [Completed]. Perform [Start] after waiting 1 minute or more.

When the Remote Operation is started up, the operation panel screen will be displayed on the system administrator's or user's PC screen.

Executing Remote Operation from VNC Software

1 Display the screen

- 1 [System Menu/Counter] key > [▲][▼] keys > [System/Network] > [OK] key > [▲][▼] keys > [Network Setting] > [OK] key > [▲][▼] keys [ProtocolSettings] > [OK] key > [▲][▼]keys [VNC (RFB)] > [OK] key

2 [▲][▼] keys > [On] > [OK] key



NOTE

- If "VNC (RFB) over TLS" is set to On, the communication is encrypted.
- You can configure the protocol settings using Command Center RX.

➔ [Command Center RX User Guide](#)

3 Startup the remote operation.

- 1 Start up the VNC software.
- 2 Enter the following format separated by a colon to start up the remote operation.
"IP address: port number"



NOTE

When setting "VNC (RFB)" to On in step 2, the default port number is 9062. When "VNC (RFB) over TLS" is set to On, the default port number is 9063.

➔ [\[ProtocolSettings\] \(page 394\)](#)

Responding to Messages

If the touch panel or the computer displays any of these messages, follow the corresponding procedure.

NOTE

When contacting us, the serial number will be necessary. To check the serial number, refer to the following:

[□ □ Checking the Equipment's Serial Number \(page 2\)](#)

"Access point was not detected. " is displayed

Check if the access point has been set correctly.

"Load paper in cassette #." is displayed.

Has the paper run out in the displayed paper source?

Replenish the paper.

➔ [Loading in the Cassettes \(page 133\)](#)

To print with paper from another paper source, select [Paper]. Select the paper source from [Paper Selection] and then select the [OK] key.

Select [OK] key to print without changing the paper source.

"Load paper in MP tray." is displayed.

Does the paper source paper size setting not match the actual paper size that is fed?

There is no paper in the multipurpose tray that matches the print data. Set the paper. Select [OK] to resume printing.

To print with paper from another paper source, select [Paper]. Select the paper source from [Paper Selection] and then select the [OK] key.

Select [Cancel] to cancel the job.

"Box limit exceeded. Job is canceled. " is displayed

Jobs cannot be saved because the specified box is full. The job is canceled.

Print or delete the original in the box, and then try again.

"Broadcast error Job is canceled. " is displayed

An error occurred while broadcasting.

The job is canceled. Select [OK] key.

"Cannot connect to authentication server Contact the administrator." is displayed

Does the machine time match the server's time?

- Set the machine time to match the server's time
 - ➔ [Setting Date and Time \(page 67\)](#)

Is it properly registered with the authentication server?

- Enable User Login Administration.
 - ➔ [Enable User Login Administration \(page 484\)](#)
- Set the network authentication server.
 - Check the connection status with the server.
 - Confirm that the computer name and password for the authentication server are correct.

Is the machine connected to the network correctly?

- ➔ [Connecting LAN Cable \(page 52\)](#)
- ➔ [Network Setup \(page 69\)](#)



If Auto Error Clear is set to [On], the process will resume automatically after a set period of time. For details, refer to the following:

- ➔ [\[Error Handling\] \(page 440\)](#)
-

"Cannot connect to the server." is displayed

Check the connection status with the server.

"Cannot connect. " is displayed

Wi-Fi or Wi-Fi Direct connection could not be completed.

Select [OK]. Returns to the previous screen.

Check the settings and signal conditions.

➔ [\[Wi-Fi Direct Set\] \(page 377\)](#)

➔ [\[Wi-Fi Settings\] \(page 379\)](#)

"Cannot duplex print on this paper." is displayed

Have you selected a size or type of paper that cannot be duplex printed?

To print on paper from another paper source, select [Paper]. Select the paper source from [Paper Selection] and then select the [OK] key.

Select [OK] key to cancel duplex printing and continue printing.

Select [Cancel] to cancel the job.

"Cannot perform remote printing. Job is canceled." is displayed

Remote printing is prohibited.

The job is canceled. Select [OK].

"Printing multiple copies is not allowed." is displayed.

Only one copy is available.

- Select [Continue] to continue printing.
- Select [Canceled] to cancel the job.

"Cannot use this function. Restricted by authorization settings." is displayed.

Restricted by the authorization settings.

The job is canceled. Select [OK].

"Restricted by Job Accounting. Cannot print." is displayed.

Restricted by the job accounting.

The job is canceled. Select [OK].

"This user account has been locked out. You cannot login." is displayed.

Please contact the administrator.

The job is canceled. Select [OK].

"Cannot use this function." is displayed.

This job will be aborted because user authorization prohibits that function. Select [OK].

"Cannot read data in this ID Card. " is displayed

In registration process, the ID card information was not read correctly.

Hold the IC card over the IC card reader again. If the same message is displayed again, the IC card may not be compatible with this product. Replace it with another IC card.

is displayed.

- Check if the USB connector of your IC card reader is correctly connected to the main unit.
- If [USB Host] in [I/F Block Set.] is set to [Block], change it to [Unblock].

is displayed.

Failed to activate the application.

Please contact the administrator.

Extended authentication is disabled.

Turn the power switch off and then on again. If the error persists, contact administrator.

1 Turn the power switch off.

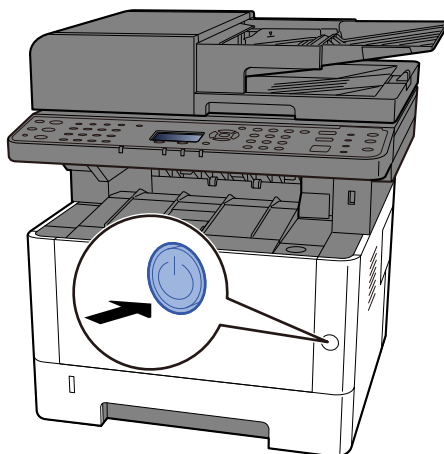

The confirmation message for power supply off is displayed.

It takes approximately 3 minutes for power off.

CAUTION

If this machine will be left unused for an extended period (e.g. overnight), turn it off at the power switch. If the machine will not be used for an even longer period of time (e.g. vacation), remove the power plug from the outlet as a safety precaution.

IMPORTANT

- If using the products equipped with the fax function, note that turning the machine off at the power switch disables fax transmission and reception.
 - Remove paper from the cassettes and seal it in the paper storage bag to protect it from humidity.
-

"Failed to send via SMB." is displayed.

Are this machine and the scanned image destination PC connected to the network?

Check the network.

- Connecting LAN Cable
- Hub behavior
- The server status
- Host name or IP address
- Port number

➔ [Connecting LAN Cable \(page 52\)](#)

➔ [Network Setup \(page 69\)](#)

➔ [\[Network Setting\] \(page 375\)](#)

Is the account information (user ID, password) used to access the shared folder to which the scanned image is to be sent incorrect?

Check the settings of the scanned image destination PC.

- Host Name
- Path
- Login user name



If the sender is a domain user, specify the domain name. [Login User name]@[Domain name]

Example) sa720XXXX@km

- Login Password
 - Folder share permissions of the recipient
-

"Failed to store job retention data. Job is canceled. " is displayed

The job is canceled. Select [OK].

"Account error." is displayed.

Failed to specify Job Accounting when processing the job externally.

The job is canceled. Select [OK].

 **NOTE**

If Auto Error Clear is set to [On], the process will resume automatically after a set period of time. For details, refer to the following:

➔ [\[Error Handling\] \(page 440\)](#)

"Incorrect account ID. " is displayed

The account ID was incorrect when processing the job externally.

The job is canceled. Select [OK].

"Job Accounting restriction exceeded. " is displayed

Is the acceptable printing count restricted by Job Accounting exceeded?

The printing count exceeded the acceptable count restricted by Job Accounting. Cannot print any more.

The job is canceled. Select [OK].

"KPDL error. Job is canceled. " is displayed

PostScript error has occurred.

The job is canceled. Select [OK].

 **NOTE**

If Auto Error Clear is set to [On], the process will resume automatically after a set period of time. For details, refer to the following:

➔ [\[Error Handling\] \(page 440\)](#)

"Error occurred. Turn the power switch off and on." is displayed

error has occurred.

Turn the power Off/On. If the problem is not solved, make a note of the error code displayed on the screen and contact service representative.

"Machine failure. Call service. " is displayed

Internal error has occurred.

Make a note of the error code displayed on the screen and contact service representative.

"Maximum Number of scanned pages. Job is canceled." is displayed

Is the acceptable scanning count exceeded?

Cannot scan pages any more. The job is canceled. Select [OK].

"Memory is full. Job is canceled. " is displayed

The memory is full and the job cannot be continued.

Select [OK]. This job is [Cancel]. When insufficient memory occurred frequently, contact your dealer or service representative.

 **NOTE**

If Auto Error Clear is set to [On], the process will resume automatically after a set period of time. For details, refer to the following:

➔ [\[Error Handling\] \(page 440\)](#)

"Paper jammed in ###." is displayed

A paper jam has occurred.

If a paper jam occurs, the machine will stop and the location of the jam will be indicated on the screen. Leave the machine on and follow the instructions to remove the jammed paper.

➔ [Jam Location Indicators \(page 740\)](#)

"Refreshing drum... Please wait." is displayed

The machine is in adjustment mode to maintain quality.

Please wait.

"Regulating the temp.." is displayed.

The machine is in adjustment mode to maintain quality.

Please wait.

"Remove original from document processor." is displayed.

Are there any originals left in the document processor?

Remove the original from the document processor.

✔ IMPORTANT

If the paper tears during removal, be sure to remove any loose scraps of paper from inside the machine. Scraps of paper left in the machine could cause subsequent jamming.

1 Remove the originals from the Original Table.

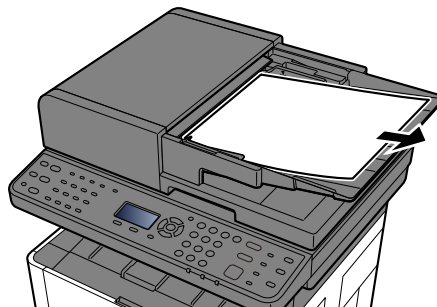

2 Open the top cover and remove the jammed paper.

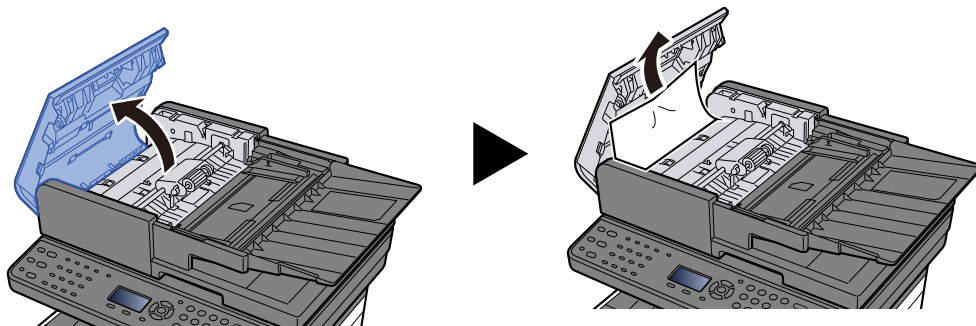

3 Remove the original from the document processor.

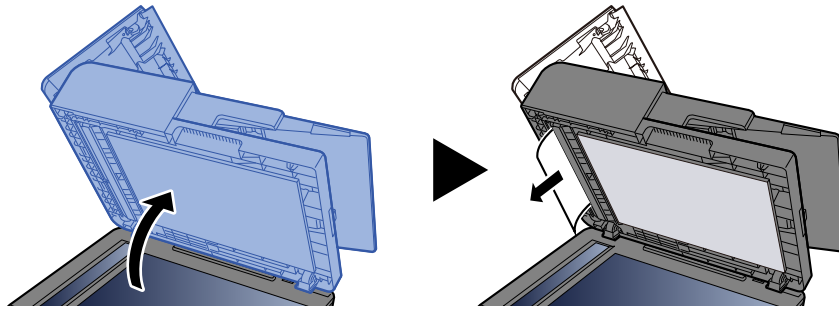

4 Return the cover to the original position.

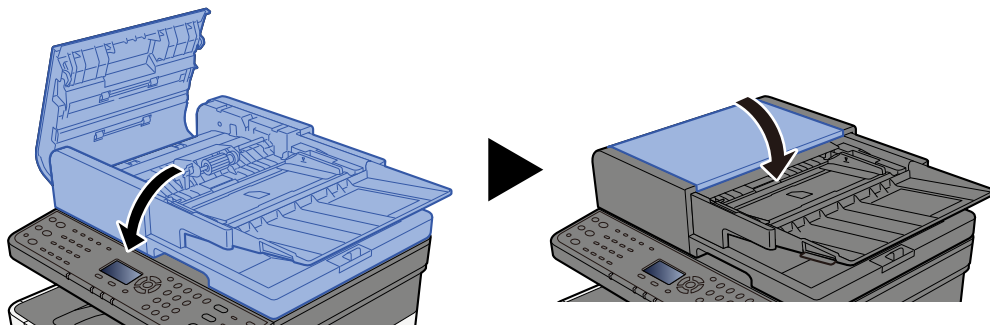

"Scanner memory is full. Job is canceled." is displayed

Scanning cannot be performed due to insufficient memory of the scanner.

The job is canceled. Select [OK].

"Scheduled sending jobs exceeded. Job is canceled." is displayed

The number of timer transmissions that can be set has been exceeded.

Select [OK]. The job is canceled.

Wait until the delayed transmission is executed, or cancel the delayed transmission and then perform the job again.

"Send error. " is displayed

An error has occurred during sending.

The job is canceled. Select [OK]. Refer to the transmission error code list for the error code and its details.

➔ [List of Transmission Error Codes \(page 684\)](#)

NOTE

If Auto Error Clear is set to [On], the process will resume automatically after a set period of time. For details, refer to the following:

➔ [\[Error Handling\] \(page 440\)](#)

"The device cannot be connected because allowed connections would be exceeded." is displayed

Are you connecting more than the maximum number of Wi-Fi Direct connections?

Disconnect the devices that you are not using, or set the [Disconnect Timer] of this unit to disconnect the devices.

➔ [\[Wi-Fi Direct Set\] \(page 377\)](#)

"The password does not meet password policy requirements. Job is canceled." is displayed.

Has your password expired?

Change the login password. The job is canceled. Select [OK].

➔ [Password Policy Settings \(page 486\)](#)

➔ [Change the user properties \(page 491\)](#)

Have your password policy requirements changed (password length, strings of characters to use, etc.)?

Check your password policy requirements and change the login password.

The job is canceled. Select [OK].

➔ [Password Policy Settings \(page 486\)](#)

➔ [Change the user properties \(page 491\)](#)

"MaliciousPRG detected Delete the program. Contact the admin." is displayed.

Execution was aborted due to a possible malware program.

The names of applications for which malware has been detected are displayed.

Please contact the administrator.

"RAM disk error. Press [OK]. " is displayed

A RAM disk error has occurred.

The job is canceled. Select [OK].

The following error code is possible:

04: There is not enough free space on the RAM disk. If the optional RAM disk is installed, increase the RAM disk size by using [RAM Disk Mode] in the System Menu.

➔ [RAM Disk Mode \(page 453\)](#)

"TMaintenance Kit near end." is displayed.

Contact your service representative

The maintenance kit needs to be replaced.

The maintenance kit needs to be replaced at every 100,000 pages of printing.

"The slit glass requires cleaning." is displayed.

The slit glass requires cleaning.

When using the document processor, clean the slit glass surface and the reading guide with the dry cloth.

When cleaning is finished, select [OK].

✔ IMPORTANT

Do not use water, soap or solvents for cleaning.

💡 NOTE

Dirt on the slit glass or the reading guide may cause black streaks to appear in the output.

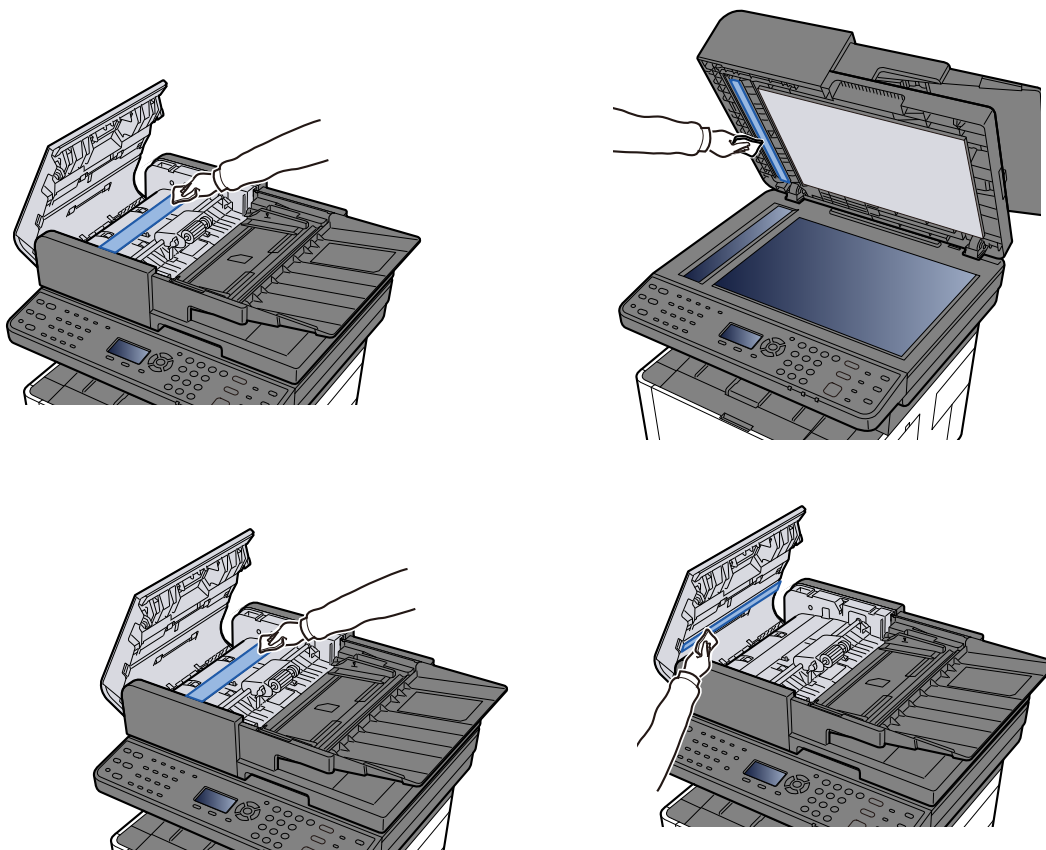

"Replace the toner." is displayed.

Replace the toner container to our specified toner container.

CAUTION

Do not attempt to incinerate parts which contain toner. Dangerous sparks may cause burns.

Here, we'll explain the procedures for replacing the toner container.

1 Open the top cover.

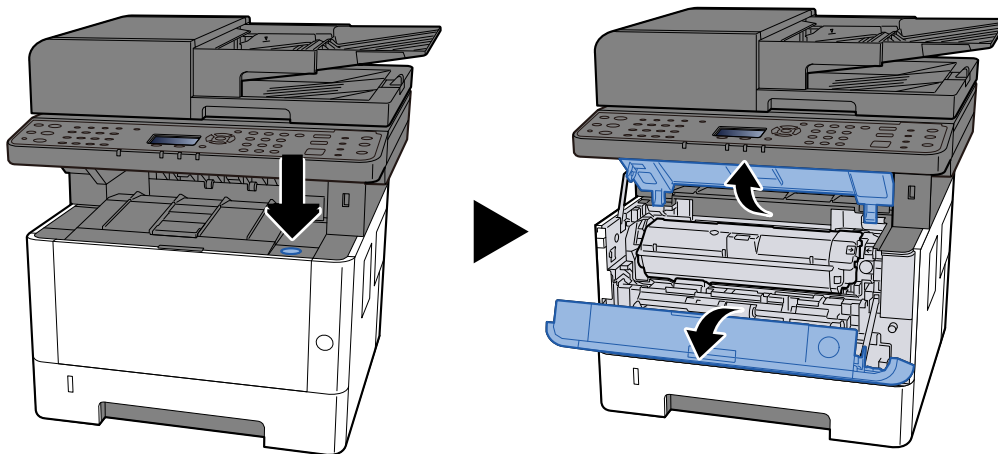

2 unlock

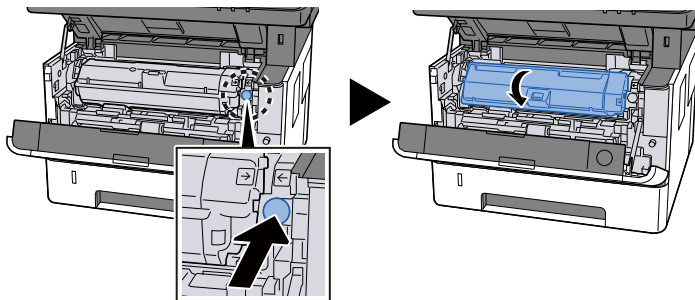

3 Remove the toner container.

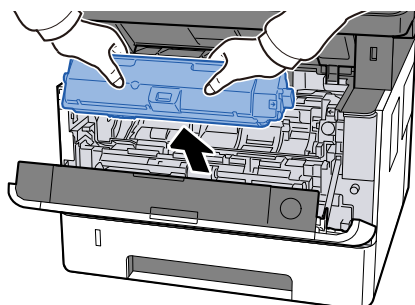

4 Put the toner container into the toner container collection bag.

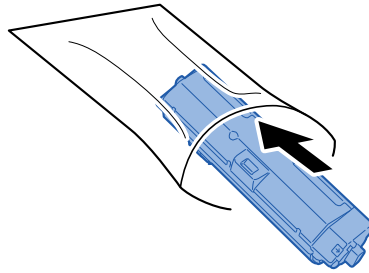

5 Remove the new toner container from the box.

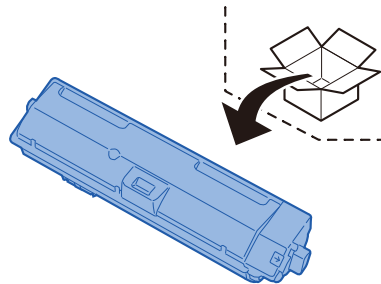

✔ IMPORTANT

Do not touch the points shown below.

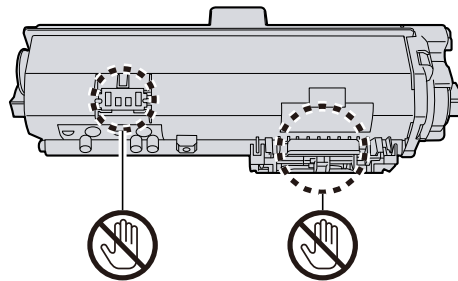

6 Shake the toner container 5 to 6 times.

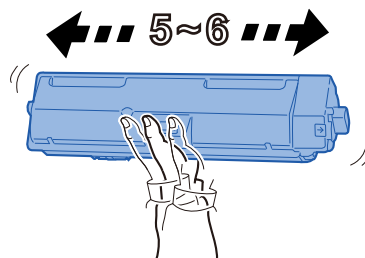

7 Install the toner container.

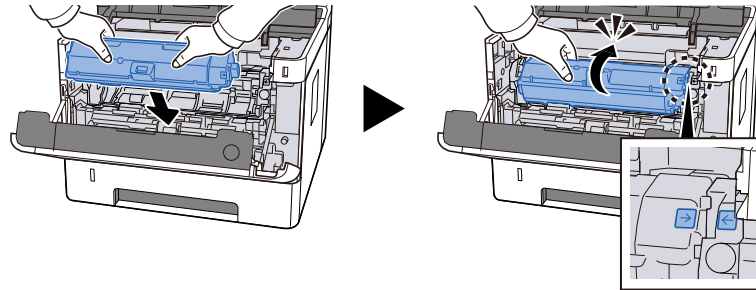

8 Close the top cover.

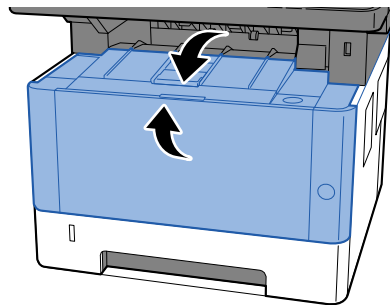

NOTE

- If the front cover does not close, check that the new toner container is installed correctly.
- Return the exhausted toner container to your dealer or service representative. The collected toner container will be recycled or disposed in accordance with the relevant regulations.

"Toner is low." "(Replace when empty.)" is displayed.

It is almost time to replace the toner container.

Obtain a new toner container.

"Non-genuine Toner. Press [Help]." is displayed.

Does the type of toner you have match the model?

Select [Help] and follow the instructions on the screen.

"Unknown toner installed." is displayed.

Does the sales region of the toner you have match the sales region of the main body?

Use the toner that matches the sales region of the main body.

"The toner container is improperly installed." is displayed.

Are the toner container and developer unit installed properly?

The toner cartridge is not installed properly.

➔ [Clean the inside of the main unit \(page 543\)](#)

"USB Drive error. Job is canceled. " is displayed

Is the USB drive write-protected?

An error occurred in the USB drive. The job is canceled. Select [OK].

The following error code is displayed:

01: Connect a writeable USB drive.

An error occurred in the USB drive.

The job is canceled. Select [OK].

The following error code is displayed:

01: The amount of data that can be saved at once has been exceeded. Restart the system or turn the power OFF/ON.

If the error still occurs, divide the file into smaller files. If the error persists, the USB drive is not compatible with the machine. Use the USB drive formatted by this machine. If the USB drive cannot be formatted, it is damaged. Connect a compatible USB drive.



NOTE

If Auto Error Clear is set to [On], the process will resume automatically after a set period of time. For details, refer to the following:

➔ [\[Error Handling\] \(page 440\)](#)

"USB Drive is full. Job is canceled." is displayed

There is not enough free space on the USB drive.

The job is canceled.

Delete unnecessary files on the USB drive.

 **NOTE**

If Auto Error Clear is set to [On], the process will resume automatically after a set period of time. For details, refer to the following:

➔ [\[Error Handling\] \(page 440\)](#)

"Memory card error. Job is canceled." is displayed.

An error has occurred on the memory card.

An error has occurred on the memory card. The job is canceled. Select .

04: There is not enough free space on the memory card. Move data or delete unneeded data.

"High temperature." "Adjust room temp." is displayed.

Print quality may be deteriorated. Adjust the temperature and the humidity of your room.

"Low temperature." "Adjust room temp." is displayed

Print quality may be deteriorated. Adjust the temperature and the humidity of your room.

"Insufficient memory. Cannot start the job." is displayed.

Cannot start the job. Try again later.

"You cannot use this box. Job is canceled." is displayed

This job will be aborted because user authorization prohibits that function. Select [OK].

List of Transmission Error Codes

1101 "Failed to send the email." is displayed

Message

Failed to send email.

Check the host name of the SMTP server with Command Center RX.
The job is canceled. Press [OK].

Corrective Action

Enter the host name of the SMTP server in Command Center RX.

- 1 Launch your Web browser.**
- 2 In the address or location bar, enter the machine's IP address or the host name.**
- 3 Log in with administrator privileges.**
- 4 Click [Functions] in the [E-mail] menu**
- 5 Check the [SMTP Server Name] in "SMTP".**
Correct anything that is incorrect.
- 6 Click [Submit].**
→ [SMTP and E-mail Settings \(page 116\)](#)

1101 "Failed to send via SMB." is displayed

Message

Unable to send SMB.

Check your SMB settings.

>Login user name or login password

Reference:

If the sender is a domain user, specify the domain name.

>Host name

>Path

The job is canceled. Press [OK].

Corrective Action

Check the host name of the destination computer.

1 **When entering the destination information, make sure that the host name or IP address of the destination computer is correct.**

➔ [Sending Document to Desired Shared Folder on a Computer \(Scan to PC\) \(page 236\)](#)



NOTE

If the sender is a domain user, specify the domain name.

To specify a destination registered in the address book, proceed to the next step.

2 **Check the Address Book**

1 [System Menu/Counter] key > [▲] [▼] keys > [Edit Destination] > [OK] key > [▲] [▼] keys > [Address Book] > [OK] key

2 Select the destinations (Individual) > [OK] key

3 Make sure that the host name or IP address of the destination computer is correct.



NOTE

If the sender is a domain user, specify the domain name.

If it is incorrect, correct it.

4 [OK] key > [Yes]

Register the changed destination.

➔ [Editing Contact Address in Address Book \(page 169\)](#)

1101 "Failed to send via FTP." is displayed

Message

Unable to send FTP.
Check the FTP "Host name" or "IP address".
The job is canceled. Press [OK].

Corrective Action

Check the host name of the FTP.

1 When entering the destination information, make sure that the host name or IP address of the FTP server is correct.

➔ [Sending Document to Folder on an FTP Server \(Scan to FTP\) \(page 238\)](#)

To specify a destination registered in the address book, proceed to the next step.

2 Check the Address Book

- 1 [System Menu/Counter] key > [▲] [▼] keys > [Edit Destination] > [OK] key > [▲] [▼] keys > [Address Book] > [OK] key
- 2 Select the destinations (Individual) to check > [OK] key
- 3 Make sure that the host name or IP address of the FTP server is correct.
If it is incorrect, correct it.
- 4 [OK] key > [Yes]
Register the changed destination.

➔ [Editing Contact Address in Address Book \(page 169\)](#)

1102 "Failed to send the email." is displayed

Message

Failed to send the email.

Check the followings on the Command Center RX

- > SMTP login user name and login password
- > POP3 login user name and login password

1102

Corrective Action

Check the login user name and password for the SMTP server and POP3 server.

- 1 Launch your Web browser.**
- 2 In the address or location bar, enter the machine's IP address or the host name.**
- 3 Log in with administrator privileges.**
- 4 Click [Functions] in the [E-mail] menu**
- 5 Check whether the login user name and password for the SMTP server have been entered in [Authentication Protocol] of "SMTP", and change the settings as necessary.**
- 6 Click [Settings] in "POP3 User Settings"**
- 7 Check whether the login user name and password have been entered and change the settings as necessary.**
- 8 Click [Submit].**

➔ [SMTP and E-mail Settings \(page 116\)](#)

1102 "Failed to send via SMB." is displayed

Message

Unable to send SMB.
 Check your SMB settings.
 >Login user name or login password
 Reference:
 If the sender is a domain user, specify the domain name.
 >Host name
 >Path
 The job is canceled. Press [OK].

Corrective Action

Check the login user name and password of the destination computer.

1 When entering the destination information, make sure that the login user name and password of the destination computer is correct.

➔ [Sending Document to Desired Shared Folder on a Computer \(Scan to PC\) \(page 236\)](#)



NOTE

- If the computer name and domain name are different, check that they are entered as follows.
 Domain name\User name
- If you use a host name, make sure it does not contain the following forbidden characters:
 `~!@#\$%^&*()=+[]{} \ | ; : ' " < > / ?

To specify a destination registered in the address book, proceed to the next step.

2 Check the Address Book

- 1 [System Menu/Counter] key > [▲] [▼] keys > [Edit Destination] > [OK] key > [▲] [▼] keys > [Address Book] > [OK] key
- 2 Select the destinations (Individual) > [OK] key
- 3 Make sure that the login user name and password of the destination computer are correct.
 If it is incorrect, correct it.



NOTE

- If the computer name and domain name are different, check that they are entered as follows.
 Domain name\User name
- If you use a host name, make sure it does not contain the following forbidden characters:
 `~!@#\$%^&*()=+[]{} \ | ; : ' " < > / ?

4 [OK] key > [Yes]

Register the changed destination.

➔ [Editing Contact Address in Address Book \(page 169\)](#)

1102 "Failed to send via FTP." is displayed

Message

Unable to send FTP.

Check your FTP settings.

>Login user name or login password

Reference:

If the sender is a domain user, specify the domain name.

The job is canceled. Press [OK].

Corrective Action

Check the login user name and password for the FTP.

1 When entering the destination information, make sure that the login user name and password of the FTP server is correct.

➔ [Sending Document to Folder on an FTP Server \(Scan to FTP\) \(page 238\)](#)



NOTE

- If the sender is a domain user, specify the domain name.
- If the computer name and domain name are different, check that they are entered as follows.

Domain name\User name

To specify a destination registered in the address book, proceed to the next step.

2 Check the Address Book

- 1 [System Menu/Counter] key > [▲] [▼] keys > [Edit Destination] > [OK] key > [▲] [▼] keys > [Address Book] > [OK] key
 - 2 Select the destinations (Individual) > [OK] key
 - 3 Make sure that the login user name and password of the FTP are correct.
-



NOTE

- If the sender is a domain user, specify the domain name.
- If the computer name and domain name are different, check that they are entered as follows.

Domain name\User name

If it is incorrect, correct it.

- 4 [OK] key > [Yes]

Register the changed destination.

➔ [Editing Contact Address in Address Book \(page 169\)](#)

1103 "Failed to send via SMB." is displayed

Message

Unable to send SMB.

Check your SMB settings.

>Login user name or login password

Reference:

If the sender is a domain user, specify the domain name.

> Path

> Folder share permissions of the recipient

The job is canceled. Press [OK].

Corrective Action

Check the login user name and password of the destination computer, and the destination folder path.

- 1 When entering the destination information, make sure that the login user name and password of the destination computer, and the destination folder path are correct.**

➔ [Sending Document to Desired Shared Folder on a Computer \(Scan to PC\) \(page 236\)](#)



NOTE

If the computer name and domain name are different, check that they are entered as follows.

Domain name\User name

To specify a destination registered in the address book, proceed to the next step.

2 Check the Address Book

- [System Menu/Counter] key > [▲] [▼] keys > [Edit Destination] > [OK] key > [▲] [▼] keys > [Address Book] > [OK] key
 - Select the destinations (Individual) > [OK] key
 - Make sure that the login user name and password of the destination computer are correct.
If it is incorrect, correct it.
-



NOTE

If the computer name and domain name are different, check that they are entered as follows.

Domain name\User name

- [OK] key > [Yes]
Register the changed destination.

➔ [Editing Contact Address in Address Book \(page 169\)](#)

3 Make sure the folder sharing settings are configured correctly

Check the sharing settings and access permissions in the folder properties.

- 1 Right-click the shared folder and click [Properties] → [Security], in that order.
- 2 Select a user and make sure the user you entered in the group name or user name field is displayed
- 3 Make sure that checkmarks appear on the [Allow] checkbox for "Modify" and "Read & execute".
- 4 Click the [OK] button.
 - ➔ [Create a shared folder and make a note of the shared folder name \(page 145\)](#)

1103 "Failed to send via FTP." is displayed

Message

Failed to send via FTP.
Check the FTP settings.
> Login user name and login password

1103

Corrective Action

Check the destination folder path.

- 1 When entering the destination information, make sure that the login user name and password of the destination computer, and the destination folder path are correct.**

➔ [Sending Document to Folder on an FTP Server \(Scan to FTP\) \(page 238\)](#)



NOTE

If no path is entered, the file is stored in the home directory.

To specify a destination registered in the address book, proceed to the next step.

2 Check the Address Book

- 1 [System Menu/Counter] key > [▲] [▼] keys > [Edit Destination] > [OK] key > [▲] [▼] keys > [Address Book] > [OK] key
 - 2 Select the destinations (Individual) > [OK] key
 - 3 Make sure that the destination folder path is correct.
-



NOTE

If no path is entered, the file is stored in the home directory.

If it is incorrect, correct it.

- 4 [OK] key > [Yes]
Register the changed destination.

➔ [Editing Contact Address in Address Book \(page 169\)](#)

1104 "Failed to send the email." is displayed

Message

Failed to send email.

Check the Email Address.

Reference

You cannot send it if it is denied by domain restriction.

The job is canceled. Press [OK].

Corrective Action

Check the Email Address.

1 When entering the destination information, make sure that the email address is correct.

➔ [Sending Document via E-mail \(page 235\)](#)

To specify a destination registered in the address book, proceed to the next step.

2 Check the Address Book

1 [System Menu/Counter] key > [▲] [▼] keys > [Edit Destination] > [OK] key > [▲] [▼] keys > [Address Book] > [OK] key

2 Select the destinations (Individual) > [OK] key

3 Check the Email Address

If it is incorrect, correct it.

4 [OK] key > [Yes]

Register the changed destination.

➔ [Editing Contact Address in Address Book \(page 169\)](#)

If there is no improvement, proceed to the next step.

3 Make sure your email address is not rejected due to domain restrictions

1 Launch a web browser.

2 In the address or location bar, enter the machine's IP address or the host name.

3 Log in with administrator privileges.

4 Click [Functions] in the [E-mail] menu

5 Click [Domain List] in "SMTP"

The SMTP domain restriction list is displayed.

6 If the email address you use is included in the list, delete it.

7 Click [Submit] twice.

➔ [SMTP and E-mail Settings \(page 116\)](#)

1105 "Failed to send the email." is displayed

Message

Failed to send email.
Turn SMTP [On] in Command Center RX.
The job is canceled. Press [OK].

Corrective Action

From Command Center RX, check that SMTP (email sending) is On.

- 1 Launch your Web browser.**
- 2 In the address or location bar, enter the machine's IP address or the host name.**
- 3 Log in with administrator privileges.**
- 4 Click [Network Settings] in the [Protocols] menu**
- 5 Set "SMTP (E-mail TX)" in "Send Protocol" to [On]**
- 6 Click [Submit].**
 - ➔ [SMTP and E-mail Settings \(page 116\)](#)

1105 "Failed to send via SMB." is displayed

Message

Unable to send SMB.
Turn SMB [On] in Command Center RX.
The job is canceled. Press [OK].

Corrective Action

Make sure the protocol is set correctly.

- 1 Launch your Web browser.**
- 2 In the address or location bar, enter the machine's IP address or the host name.**
- 3 Log in with administrator privileges.**
- 4 Click [Network Settings] in the [Protocols] menu**
- 5 Set "SMB" in "Send Protocol" to [On]**
- 6 Click [Submit].**
→ [SMTP and E-mail Settings \(page 116\)](#)

1105 "Failed to send via FTP." is displayed

Message

Unable to send FTP.
Turn FTP [On] in Command Center RX.
The job is canceled. Press [OK].

Corrective Action

Make sure the protocol is set correctly.

- 1 Launch your Web browser.**
- 2 In the address or location bar, enter the machine's IP address or the host name.**
- 3 Log in with administrator privileges.**
- 4 Click [Network Settings] in the [Protocols] menu**
- 5 Set "FTP Client (Transmission)" in "Send Protocol" to [On]**
- 6 Click [Submit].**
 - ➔ [SMTP and E-mail Settings \(page 116\)](#)

1106 "Failed to send the email." is displayed

Message

Failed to send email.

Check the sender address on the SMTP in Command Center RX.

The job is canceled. Press [OK].

Corrective Action

Check the sender address on the SMTP server from Command Center RX.

- 1 Launch your Web browser.**
- 2 In the address or location bar, enter the machine's IP address or the host name.**
- 3 Log in with administrator privileges.**
- 4 Click [Functions] in the [E-mail] menu**
- 5 Set the [Sender Address] in "E-mail Send Settings".**

Please specify an email address that can be received by the Machine Administrator. The sender address must be entered correctly for SMTP authentication. The maximum length of the sender address is 256 characters.

- 6 Click [Submit].**

➔ [SMTP and E-mail Settings \(page 116\)](#)

1131 "Failed to send via FTP." is displayed

Message

Unable to send FTP.
Turn the secure protocol TLS [On] in Command Center RX.
The job is canceled. Press [OK].

Corrective Action

Please set to allow the use of TLS.

- 1 Launch your Web browser.**
- 2 In the address or location bar, enter the machine's IP address or the host name.**
- 3 Log in with administrator privileges.**
- 4 Click [Security Settings] in the [Network Security] menu**
- 5 Set [TLS] to [On]**
- 6 Click [Submit].**

➔ [Command Center RX User Guide](#)

1132 "Failed to send via FTP." is displayed

Message

Unable to send FTP.
Check the destination server.
> Supports FTPS
> Supports the encryption method you have set
The job is canceled. Press [OK].

Corrective Action

Check the destination server.

- 1 Make sure the destination server supports FTPS (File Transfer Protocol over TLS)**
If there is no improvement, proceed to the next step.
- 2 Make sure the destination server supports the encryption method you have set.**

2101 "Failed to send the email." is displayed

Message

Failed to send email.

Check the Command Center RX and network settings.

> Connecting the network cables

> Hub operation

> Server status

> POP3 server name for POP3 user

> SMTP server name

The job is canceled. Press [OK].

Corrective Action

Check Command Center RX and network settings.

1 Connect the network cable

Check that the LAN cable is properly connected.

If there is no improvement, proceed to the next step.

2 Check the operation of the hub.

Check that the hub access lamp is illuminated or flashing.

If there is no improvement, proceed to the next step.

3 Check the status of the server.

Check that the server is up and responding with ping.

If there is no improvement, proceed to the next step.

4 Check the host name of the SMTP server in Command Center RX.

1 Launch a web browser.

2 In the address or location bar, enter the machine's IP address or the host name.

3 Log in with administrator privileges.

4 Click [Functions] in the [E-mail] menu

5 Check the "SMTP" [SMTP Server Name].

Correct anything that is incorrect.

6 Click [Submit].

If there is no improvement, proceed to the next step.

5 Check the users in POP before SMTP authentication in Command Center RX.

Set this when using POP before SMTP as SMTP authentication.

- 1 Launch a web browser.
- 2 In the address or location bar, enter the machine's IP address or the host name.
- 3 Log in with administrator privileges.
- 4 Click [Functions] in the [E-mail] menu
- 5 Select "Authentication Protocol"
- 6 Check that [Other] is not selected from "Authenticate as"
If this is not the case, select a valid POP3 user other than [Other].
- 7 Click [Submit] twice.
If there is no improvement, proceed to the next step.

6 Check the POP3 server name for POP3 users in Command Center RX

- 1 Launch a web browser.
- 2 In the address or location bar, enter the machine's IP address or the host name.
- 3 Log in with administrator privileges.
- 4 Click [Functions] in the [E-mail] menu
- 5 Click "POP3 User Settings"
The "POP3 User Settings" screen is displayed.
- 6 Check the [POP3 Server Name] in "User 2".
Correct anything that is incorrect.
- 7 Click [Submit] twice.

2101 "Failed to send via SMB." is displayed

Message

Unable to send SMB.

Check your network and SMB settings.

> Connecting the network cables

> Hub operation

> Server status

> Host name or IP address

> Port number

The job is canceled. Press [OK].

Corrective Action

Check your network and SMB settings.

1 Connect the network cable

Check that the LAN cable is properly connected.

If there is no improvement, proceed to the next step.

2 Check the operation of the hub.

Check that the hub access lamp is illuminated or flashing.

If there is no improvement, proceed to the next step.

3 Check the status of the server.

Check that the server is up and responding with ping.

If there is no improvement, proceed to the next step.

4 When entering the destination information, make sure that the host name or IP address of the destination computer and the port number are correct.

➔ [Sending Document to Desired Shared Folder on a Computer \(Scan to PC\) \(page 236\)](#)

To specify a destination registered in the address book, proceed to the next step.

5 Check the Address Book

1 [System Menu/Counter] key > [▲] [▼] keys > [Edit Destination] > [OK] key > [▲] [▼] keys > [Address Book] > [OK] key

2 Select the destinations (Individual) > [OK] key

3 Make sure that the host name or IP address of the destination computer and the port number are correct.

If it is incorrect, correct it.

4 [Register] > [OK]

Register the changed destination.

➔ [Editing Contact Address in Address Book \(page 169\)](#)

2101 "Failed to send via FTP." is displayed

Message

Unable to send FTP.

Check your network and FTP settings.

> Connecting the network cables

> Hub operation

> Server status

> Host name or IP address

> Port number

The job is canceled. Press [OK].

Corrective Action

Check your network and FTP settings.

1 Connect the network cable

Check that the LAN cable is properly connected.

If there is no improvement, proceed to the next step.

2 Check the operation of the hub.

Check that the hub access lamp is illuminated or flashing.

If there is no improvement, proceed to the next step.

3 Check the status of the server.

Check that the server is up and responding with ping.

If there is no improvement, proceed to the next step.

4 When entering the destination information, make sure that the host name or IP address of the destination computer and the port number are correct.

➔ [Sending Document to Folder on an FTP Server \(Scan to FTP\) \(page 238\)](#)

To specify a destination registered in the address book, proceed to the next step.

5 Check the Address Book

1 [System Menu/Counter] key > [▲] [▼] keys > [Edit Destination] > [OK] key > [▲] [▼] keys > [Address Book] > [OK] key

2 Select the destinations (Individual) > [OK] key

3 Make sure that the host name or IP address of the destination computer and the port number are correct.

If it is incorrect, correct it.

4 [OK] key > [Yes]

Register the changed destination.

➔ [Editing Contact Address in Address Book \(page 169\)](#)

2102 "Failed to send the email." is displayed

Message

Failed to send email.

Check the network.

> Connecting the network cables

> Hub operation

> Server status

The job is canceled. Press [OK].

Corrective Action

Check your network and destination server settings.

1 **Connect the network cable**

Check that the LAN cable is properly connected.

If there is no improvement, proceed to the next step.

2 **Check the operation of the hub.**

Check that the hub access lamp is illuminated or flashing.

If there is no improvement, proceed to the next step.

3 **Check the status of the server.**

Check that the server is up and responding with ping.

2102 "Failed to send via FTP." is displayed

Message

Unable to send FTP.
Check the destination server.
> Supports FTPS
> Server status
The job is canceled. Press [OK].

Corrective Action

Check your network and destination server settings.

1 Connect the network cable

Check that the LAN cable is properly connected.
If there is no improvement, proceed to the next step.

2 Check the operation of the hub.

Check that the hub access lamp is illuminated or flashing.
If there is no improvement, proceed to the next step.

3 Check the status of the server.

Check that the server is up and responding with ping.
If there is no improvement, proceed to the next step.

4 Make sure the destination server supports FTPS (File Transfer Protocol over TLS)

2103 "Failed to send the email." is displayed

Message

Failed to send email.
Check the network.
> Connecting the network cables
> Hub operation
> Server status
The job is canceled. Press [OK].

Corrective Action

Check the network.

1 Connect the network cable

Check that the LAN cable is properly connected.
If there is no improvement, proceed to the next step.

2 Check the operation of the hub.

Check that the hub access lamp is illuminated or flashing.
If there is no improvement, proceed to the next step.

3 Check the status of the server.

Check that the server is up and responding with ping.

2103 "Failed to send via FTP." is displayed

Message

Unable to send FTP.
Check the network.
> Connecting the network cables
> Hub operation
> Server status
The job is canceled. Press [OK].

Corrective Action

Check your network and destination server settings.

1 Connect the network cable

Check that the LAN cable is properly connected.
If there is no improvement, proceed to the next step.

2 Check the operation of the hub.

Check that the hub access lamp is illuminated or flashing.
If there is no improvement, proceed to the next step.

3 Check the status of the server.

Check that the server is up and responding with ping.
If there is no improvement, proceed to the next step.

4 Make sure the destination server supports FTPS (File Transfer Protocol over TLS)

2201 "Failed to send the email." is displayed

Message

Failed to send email.
Check the network.
> Connecting the network cables
> Hub operation
> Server status
The job is canceled. Press [OK].

Corrective Action

Check the network.

1 Connect the network cable

Check that the LAN cable is properly connected.
If there is no improvement, proceed to the next step.

2 Check the operation of the hub.

Check that the hub access lamp is illuminated or flashing.
If there is no improvement, proceed to the next step.

3 Check the status of the server.

Check that the server is up and responding with ping.

2201 "Failed to send via SMB." is displayed

Message

Unable to send SMB.

Check the network.

> Connecting the network cables

> Hub operation

> Server status

The job is canceled. Press [OK].

Corrective Action

Check the network.

1 Connect the network cable

Check that the LAN cable is properly connected.

If there is no improvement, proceed to the next step.

2 Check the operation of the hub.

Check that the hub access lamp is illuminated or flashing.

If there is no improvement, proceed to the next step.

3 Check the status of the server.

Check that the server is up and responding with ping.

2201 "Failed to send via FTP." is displayed

Message

Unable to send FTP.
Check the network.
> Connecting the network cables
> Hub operation
> Server status
The job is canceled. Press [OK].

Corrective Action

Check the network.

1 Connect the network cable

Check that the LAN cable is properly connected.
If there is no improvement, proceed to the next step.

2 Check the operation of the hub.

Check that the hub access lamp is illuminated or flashing.
If there is no improvement, proceed to the next step.

3 Check the status of the server.

Check that the server is up and responding with ping.

2202 "Failed to send the email." is displayed

Message

Failed to send email.
Check the network.
> Connecting the network cables
> Hub operation
> Server status
The job is canceled. Press [OK].

Corrective Action

Check the network.

1 Connect the network cable

Check that the LAN cable is properly connected.
If there is no improvement, proceed to the next step.

2 Check the operation of the hub.

Check that the hub access lamp is illuminated or flashing.
If there is no improvement, proceed to the next step.

3 Check the status of the server.

Check that the server is up and responding with ping.

2202 "Failed to send via FTP." is displayed

Message

Unable to send FTP.
Check the network.
> Connecting the network cables
> Hub operation
> Server status
The job is canceled. Press [OK].

Corrective Action

Check the network.

1 Connect the network cable

Check that the LAN cable is properly connected.
If there is no improvement, proceed to the next step.

2 Check the operation of the hub.

Check that the hub access lamp is illuminated or flashing.
If there is no improvement, proceed to the next step.

3 Check the status of the server.

Check that the server is up and responding with ping.

2203 "Failed to send via SMB." is displayed

Message

Unable to send SMB.
Check the network.
> Connecting the network cables
> Hub operation
> Server status
The job is canceled. Press [OK].

Corrective Action

Check the network.

1 Connect the network cable

Check that the LAN cable is properly connected.
If there is no improvement, proceed to the next step.

2 Check the operation of the hub.

Check that the hub access lamp is illuminated or flashing.
If there is no improvement, proceed to the next step.

3 Check the status of the server.

Check that the server is up and responding with ping.

2203 "Failed to send via FTP." is displayed

Message

Unable to send FTP.
Check the network.
> Connecting the network cables
> Hub operation
> Server status
The job is canceled. Press [OK].

Corrective Action

Check the network.

1 Connect the network cable

Check that the LAN cable is properly connected.
If there is no improvement, proceed to the next step.

2 Check the operation of the hub.

Check that the hub access lamp is illuminated or flashing.
If there is no improvement, proceed to the next step.

3 Check the status of the server.

Check that the server is up and responding with ping.

2204 "Failed to send the email." is displayed

Message

Failed to send email.

Check the size restrictions for email sending in the SMTP settings of Command Center RX.
The job is canceled. Press [OK].

Corrective Action

Check the size restrictions for email sending in the SMTP settings in Command Center RX.

- 1 Launch your Web browser.**
- 2 In the address or location bar, enter the machine's IP address or the host name.**
- 3 Log in with administrator privileges.**
- 4 Click [Functions] in the [E-mail] menu**
- 5 Check whether a restriction value is entered in [E-mail Size Limit] of "E-mail Send Settings", and change it as necessary.**
- 6 Click [Submit].**

➔ [SMTP and E-mail Settings \(page 116\)](#)

2231 "Failed to send via FTP." is displayed

Message

Unable to send FTP.
Check the network.
> Connecting the network cables
> Hub operation
> Server status
The job is canceled. Press [OK].

Corrective Action

Check the network.

1 Connect the network cable

Check that the LAN cable is properly connected.
If there is no improvement, proceed to the next step.

2 Check the operation of the hub.

Check that the hub access lamp is illuminated or flashing.
If there is no improvement, proceed to the next step.

3 Check the status of the server.

Check that the server is up and responding with ping.

3101 "Failed to send the email." is displayed

Message

Failed to send email.
Check the source and destination authentication methods.
The job is canceled. Press [OK].

Corrective Action

Check the source and destination authentication methods.

- 1 Check the source and destination authentication methods.**
Make sure that the settings for using or not using SMTP/POP authentication of the source matches those of the destination.

3101 "Failed to send via FTP." is displayed

Message

Unable to send FTP.
Check the network.
> Connecting the network cables
> Hub operation
> Server status
The job is canceled. Press [OK].

Corrective Action

Check the network.

1 Connect the network cable

Check that the LAN cable is properly connected.
If there is no improvement, proceed to the next step.

2 Check the operation of the hub.

Check that the hub access lamp is illuminated or flashing.
If there is no improvement, proceed to the next step.

3 Check the status of the server.

Check that the server is up and responding with ping.

3201 "Failed to send the email." is displayed

Message

Failed to send email.
Check the destination SMTP user authentication method.
The job is canceled. Press [OK].

Corrective Action

- 1 Check the destination SMTP user authentication method

4801 "□□□□□□□□□□[OK]□□□□□□□□" is displayed

Message

The job is canceled. Press [OK].

Corrective Action

Turn the power switch off and then on again. If it occurs repeatedly, write down the error code displayed on the message display and contact the service representative.

4802 "Failed to send the email." is displayed

Message

Failed to send email.

Check the encryption certificate for each destination in Command Center RX.

The job is canceled. Press [OK].

Corrective Action

Turn the power switch off and then on again. If it occurs repeatedly, write down the error code displayed on the touch panel and contact the service representative.

4803 "Job is canceled. Press [OK]." is displayed

Message

The job is canceled. Press [OK].

Corrective Action

Server authentication has expired. Check your network and SMTP settings.

1 Check the date and time of this machine

- 1 [System Menu/Counter] key > [▲] [▼] keys > [Common Settings] > [OK] key > [▲] [▼] keys > [Date Setting] > [OK] key
- 2 Set year, month, day and seconds
If there is no improvement, proceed to the next step.

2 Make sure the server is using the correct certificate

If the server certificate has expired, please renew it.

4804 "XXXXXXXXXXXX[OK]XXXXXXXXXXXX" is displayed

Message

The job is canceled. Press [OK].

Corrective Action

When communicating with the mail server using SMTP over TLS, communication cannot be started because the signature algorithm of the server certificate does not match the signature algorithm set on the machine.

Please access from Command Center RX to [Security Settings] > [Network Security]. Then, check the value of [Hash] of "Serverside Settings" and [Hash] of [Clientside Settings] and match it with the value on the server side.

Restart the machine after setting.

➔ [Command Center RX User Guide](#)

The error code 4901 is displayed

An error occurred while validating the server certificate.

Corrective Action

Check the SMTP server certificate.

The error code 4902 is displayed

Your certificate has expired.

Corrective Action

Check the SMTP server certificate.

The error code 4903 is displayed

An error occurred while validating the X509 certificate.

Corrective Action

Check the X509 certificate.

The error code 4904 is displayed

The certificate has been revoked.

Corrective Action

Check the SMTP server certificate.

The error code 4905 is displayed

An error occurred while setting the encryption / signing certificate.

Corrective Action

Check the settings related to the certificate and the imported certificate.

➔ **Command Center RX User Guide**

The error code 4906 is displayed

Certificate verification did not complete within the set time.

Corrective Action

- Check the verification environment of the OCSP/CRL certificate and other certificates
- Extend the timeout deadline
- Change the certificate verification level

➔ **Command Center RX User Guide**

The error code 4a02 is displayed

Failed to initialize S/MIME.

Corrective Action

Turn the power switch off and then on again. If it occurs repeatedly, write down the error code displayed on the message display, check the operation description and then contact the service representative.

The error code 4a03 is displayed

Failed to specify S/MIME encryption.

Corrective Action

Turn the power switch off and then on again. If it occurs repeatedly, write down the error code displayed on the message display, check the operation description and then contact the service representative.

The error code 4a04 is displayed

Failed to scan the S/MIME encryption certificate.

Corrective Action

- Check and correct the settings related to the S/MIME certificate.
- Turn the power switch off and then on again. If it occurs repeatedly, write down the error code displayed on the message display, check the operation description and then contact the service representative.

➔ **Command Center RX User Guide**

The error code 4a06 is displayed

Failed to specify job accounting S/MIME Signature.

Corrective Action

Turn the power switch off and then on again. If it occurs repeatedly, write down the error code displayed on the message display, check the operation description and then contact the service representative.

The error code 4a07 is displayed

Failed to scan the S/MIME signature certificate.

Corrective Action

- Check and correct the settings related to the S/MIME signature certificate.
- Turn the power switch off and then on again. If it occurs repeatedly, write down the error code displayed on the message display, check the operation description and then contact the service representative.

➔ **Command Center RX User Guide**

The error code 4a08 is displayed

The sender's email address and the email address on the signature certificate do not match.

Corrective Action

Check the sender's email address and the email address on the signature certificate, and correct the email address(es).

Other error code "Job is canceled. Press [OK]." is displayed

Message

The job is canceled. Press [OK].

Corrective Action

Select [OK] and restart the machine.

1 Turn the power switch off and then on again

If it occurs repeatedly, write down the error code displayed on the message display and contact the service representative.

Adjustment/Maintenance

Overview of Adjustment/Maintenance

If there is an image problem and the message to run adjustment or maintenance menu appears, run Adjustment/ Maintenance in the system menu.

The table below lists the primary items you can carry out.

Item	Description
[Drum Refresh][Drum]	Remove image blur and white dots from the printout.
[Altitude Adj.][Altitude Adj.]	Set this if irregular horizontal white streaks or black dots appear in images when using the machine at a high altitude of 1000 m or higher. Select the altitude that corresponds to the usage environment. If the problem persists, please select an altitude one step higher than the current setting.
[MC]	<p>Set this when the following problems occur with images.</p> <ul style="list-style-type: none"> • The white part of the image looks entirely gray • Black dots appear on the white background of the image • Irregular horizontal lines appear in the image • Part of the image is periodically faint or shows white lines • A lighter version of the previous image remains and is repeatedly printed

Perform image adjustment

1 Display the screen

- 1 [System Menu/Counter] key > [▲] [▼] keys > [Adjust/Maint.] > [OK] key > [▲] [▼] keys > [Service Setting] > [OK] key

2 Execute

- 1 Select the item to execute.
- 2 For [Drum Refresh], choose [Yes]. For [Altitude Adj.] or [MC], change the setting and select the [OK] key.

Clearing Paper Jams

If a paper jam occurs, the LCD panel will display and the machine will stop.

Jam Location Indicators

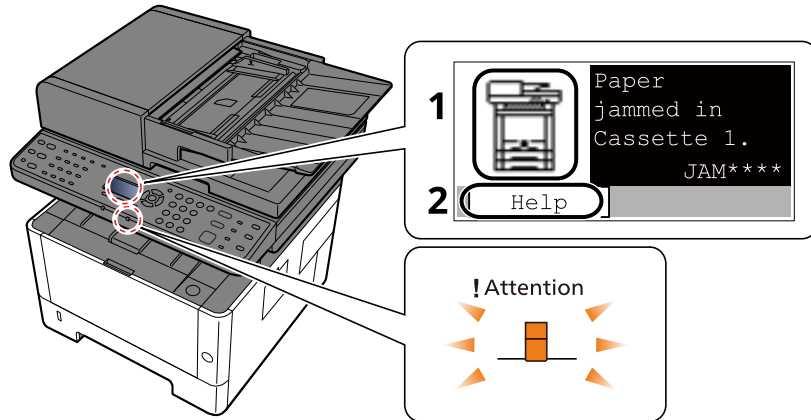

- 1 Shows the location of a paper jam.
- 2 Shows the Help screen. The Help screen shows the procedure to clear the jam.

NOTE

For the Help screen, refer to the following:

➔ [Help Screen \(page 62\)](#)

If a paper jam occurs, the location of the jam will be displayed on the touch panel as well as the clearing instructions.

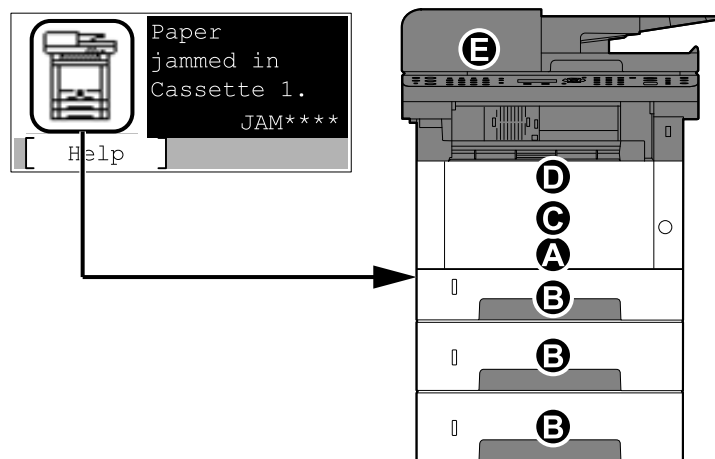

Paper Jam Location Indicator	Paper Jam Location
A	MultipurposeTray ➔ Remove any jammed paper in the Multipurpose Tray (page 742)
B	Cassette 1 to 3 ➔ Remove paper jams from Cassette 1 to Cassette 3 (page 743)

Paper Jam Location Indicator	Paper Jam Location
C	Inside the machine ➔ Remove the paper jammed inside the machine (page 745)
D	Rear Cover and Duplex Unit ➔ Remove any jammed paper in Rear Cover and Duplex Unit (page 750)
E	Document Processor ➔ Remove any jammed paper in the Document Processor (Reverse Automatic) (page 753)

After you remove the jam, the machine will warm up again and the error message will be cleared. The machine resumes with the page that was printing when the jam occurred.

Remove any jammed paper in the Multipurpose Tray

CAUTION

- Do not reuse jammed papers.
- If the paper tears during removal, be sure to remove any loose scraps of paper from inside the machine. Scraps of paper left in the machine could cause subsequent jamming.

1 Remove any jammed paper.

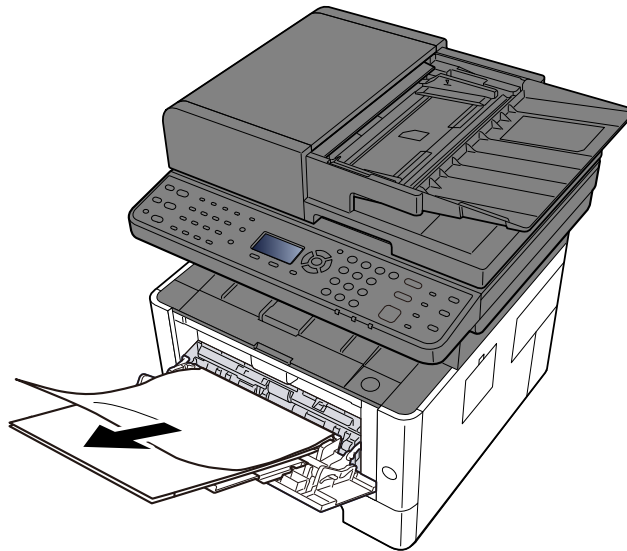

2 Remove all the paper.

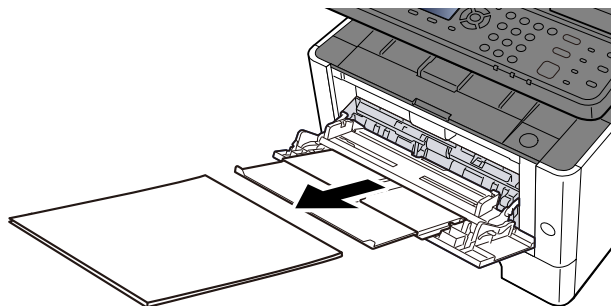

3 Reload the paper

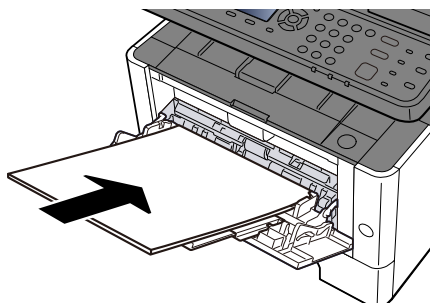

Remove paper jams from Cassette 1 to Cassette 3

The procedure for handling paper jams in cassette 1 to cassette 3 is the same. Cassette 1 is used as an example here.

CAUTION

- Do not reuse jammed papers.
- If the paper tears during removal, be sure to remove any loose scraps of paper from inside the machine. Scraps of paper left in the machine could cause subsequent jamming.

1 Pull Cassette 1 out toward you until it stops.

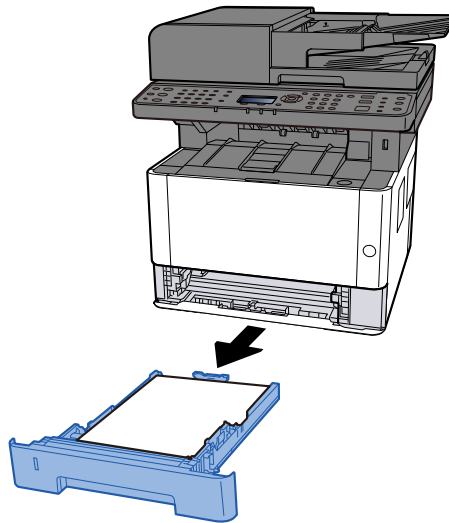

2 Remove any jammed paper.

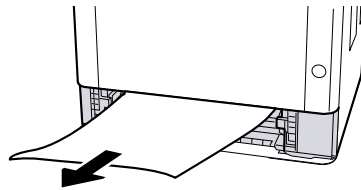

3 Push Cassette 1 back in.

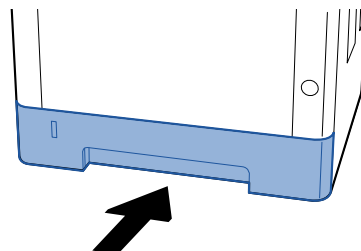

4 Open the top cover.

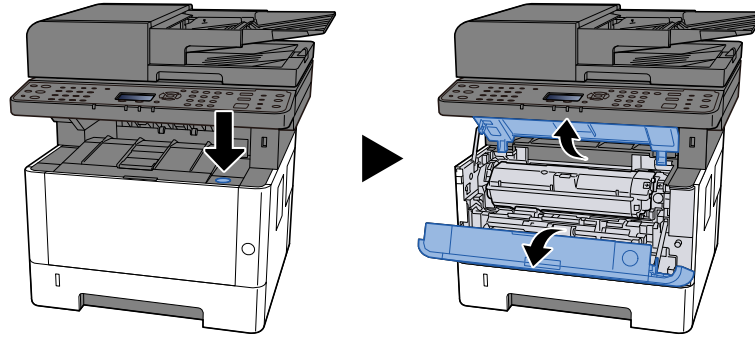

5 Close the top cover.

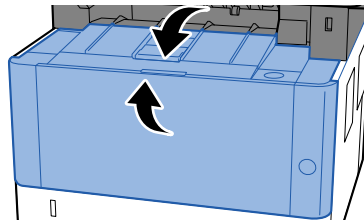

Remove the paper jammed inside the machine

CAUTION

- Do not reuse jammed papers.
- If the paper tears during removal, be sure to remove any loose scraps of paper from inside the machine. Scraps of paper left in the machine could cause subsequent jamming.

1 Pull Cassette 1 out toward you until it stops.

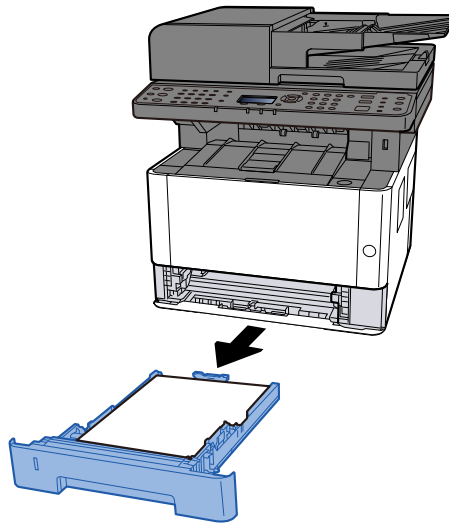

2 Remove any jammed paper.

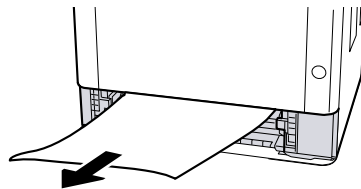

3 Push Cassette 1 back in.

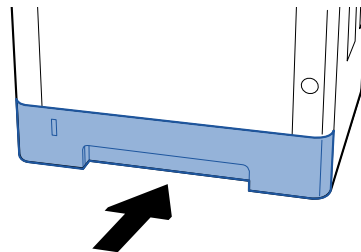

4 Open the top cover.

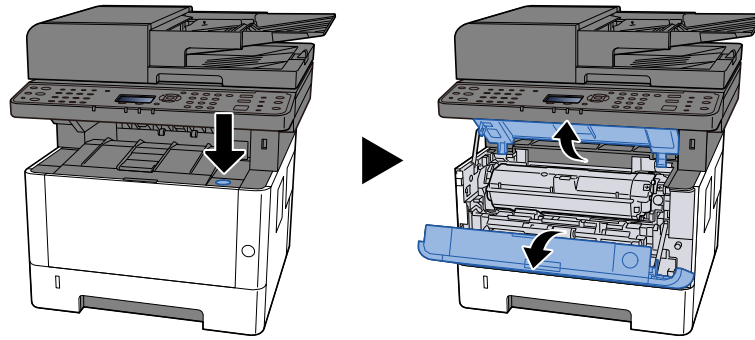

5 Remove the toner container and developer unit

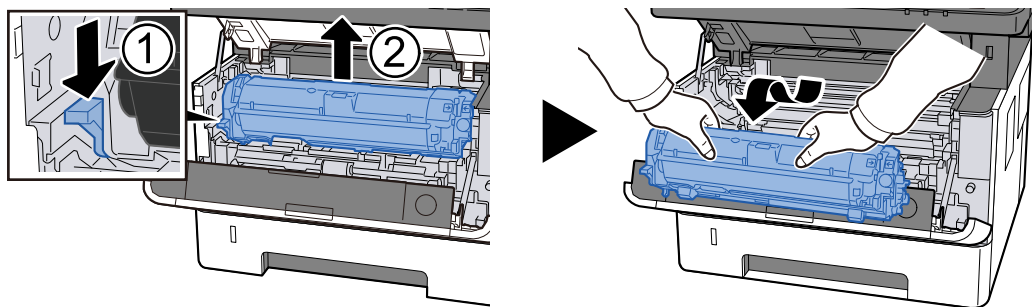

✔ **IMPORTANT**

Do not touch the developing roller or subject it to impact. Print quality will deteriorate.

6 Place the removed toner container and developer unit on a clean, level surface.

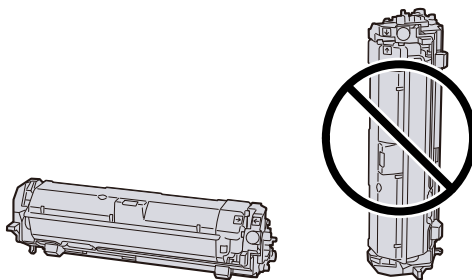

✔ IMPORTANT

Do not place the toner container and developer unit upright.

7 Take out the drum unit

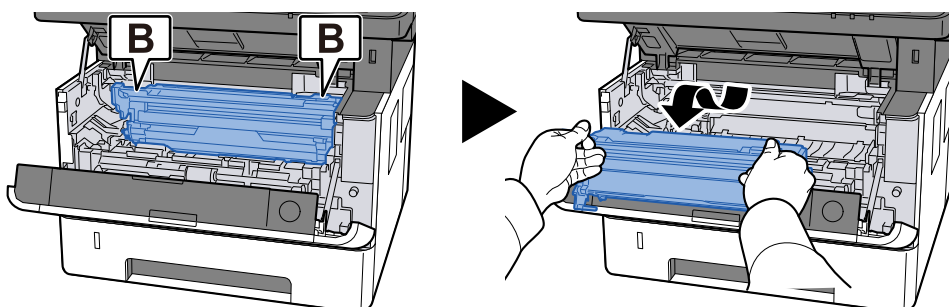

✔ IMPORTANT

- When removing the drum unit, some parts are very hot. Exercise caution as there is a risk of burn injury.
- Do not touch the drum part or subject it to impact. Also, if exposed to direct sunlight or strong light, print quality will deteriorate.

8 Place the removed drum unit on a clean, level surface.

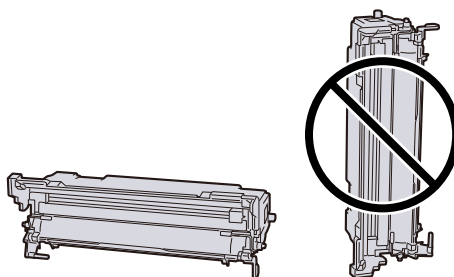

✔ IMPORTANT

Do not stand the drum unit upright.

9 Open feed cover C.

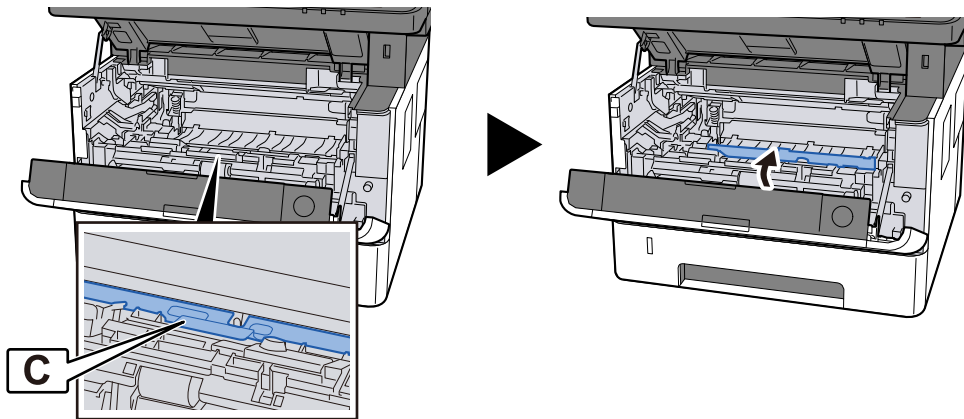

10 Remove any jammed paper.

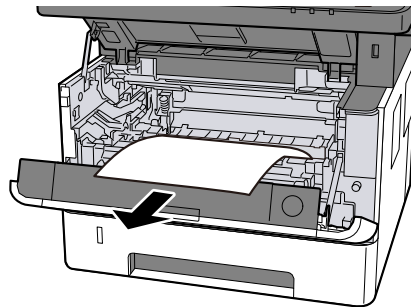

11 Close feed cover C.

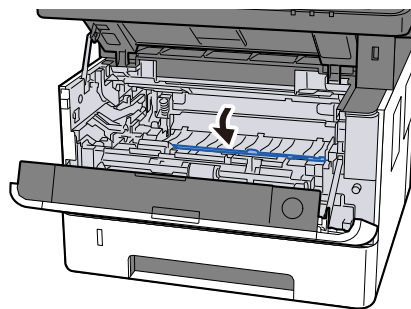

12 Return the drum unit

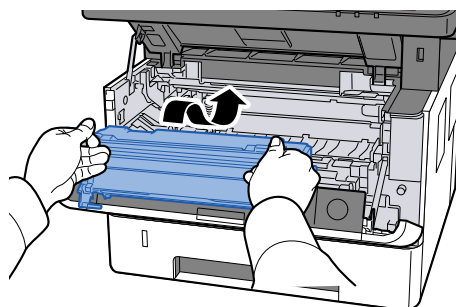

13 Return the toner container and developer unit

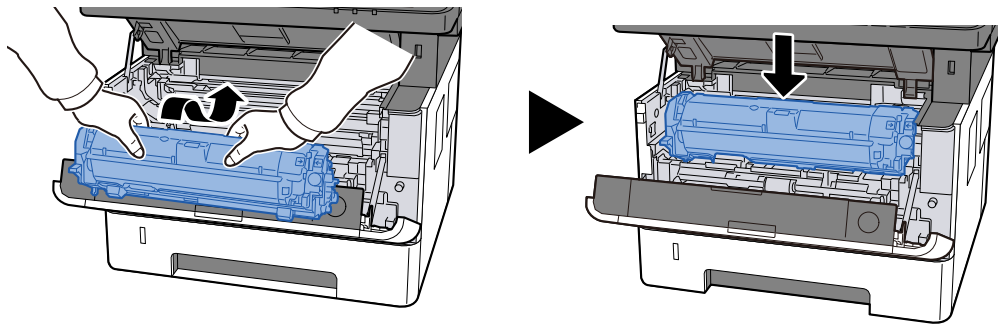

14 Close the top cover.

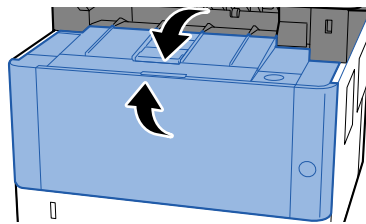

Remove any jammed paper in Rear Cover and Duplex Unit

✓ IMPORTANT

Some parts are very hot inside the machine. Exercise caution as there is a risk of burn injury.

1 Open the rear cover.

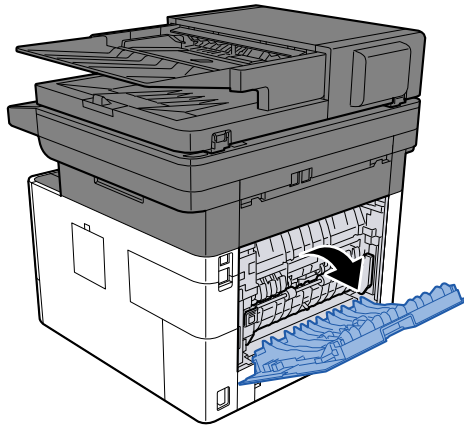

2 Remove any jammed paper.

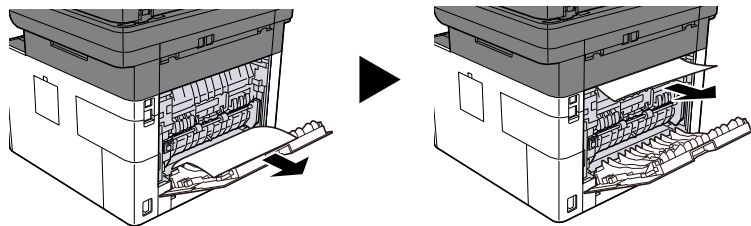

3 Open the fixed cover D.

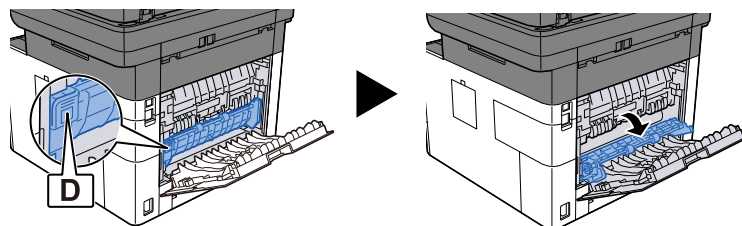

4 Remove any jammed paper.

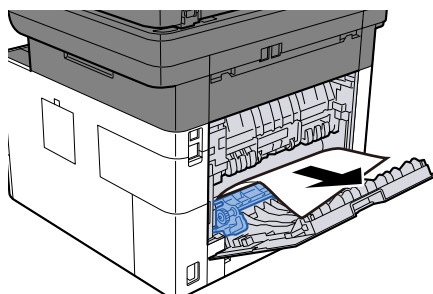

5 Pull Cassette 1 out toward you until it stops

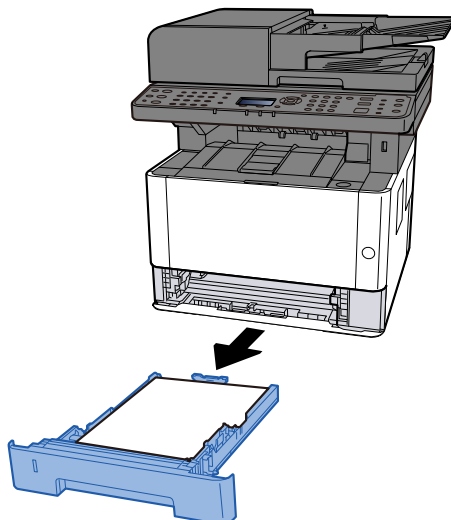

6 Open the feed cover.

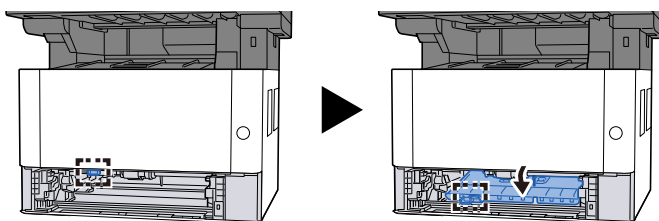

7 Remove any jammed paper.

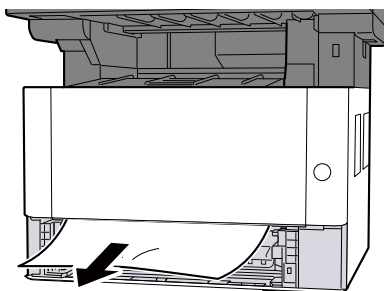

8 Return the feed cover to the original position.

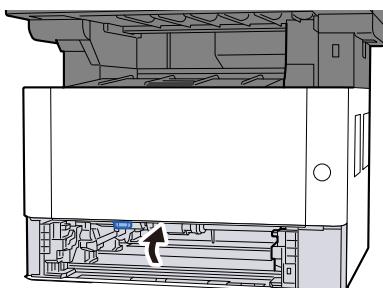

9 Push Cassette 1 back in.

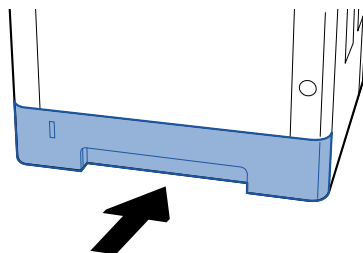

10 Return the Rear Cover to the original position.

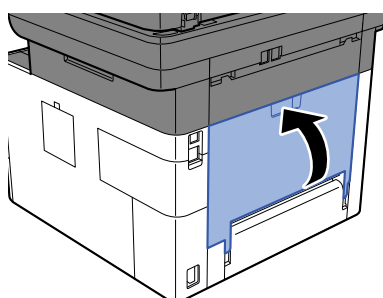

11 Open the top cover.

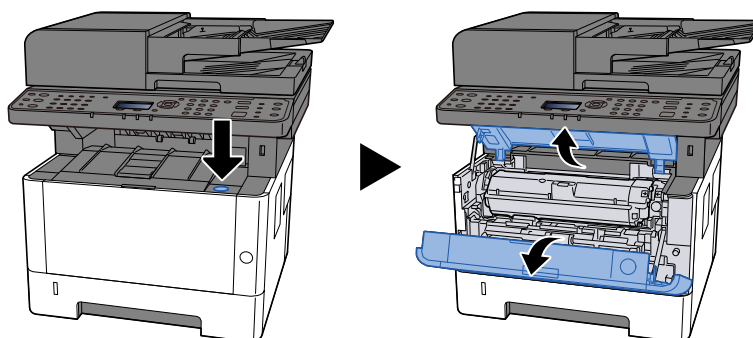

12 Close the top cover.

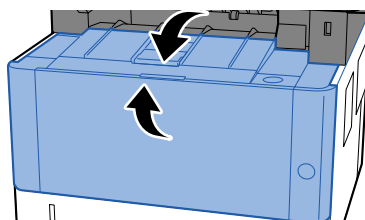

Remove any jammed paper in the Document Processor (Reverse Automatic)

✔ **IMPORTANT**

If the paper tears during removal, be sure to remove any loose scraps of paper from inside the machine. Scraps of paper left in the machine could cause subsequent jamming.

1 Remove the originals from the Original Table.

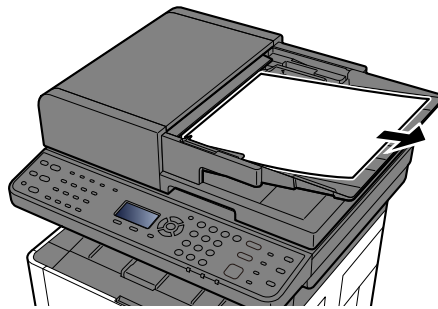

2 Open the top cover and remove the jammed paper.

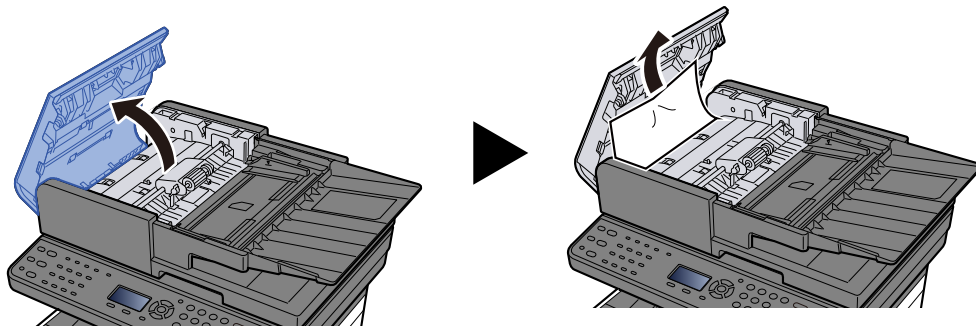

3 Remove the original from the document processor.

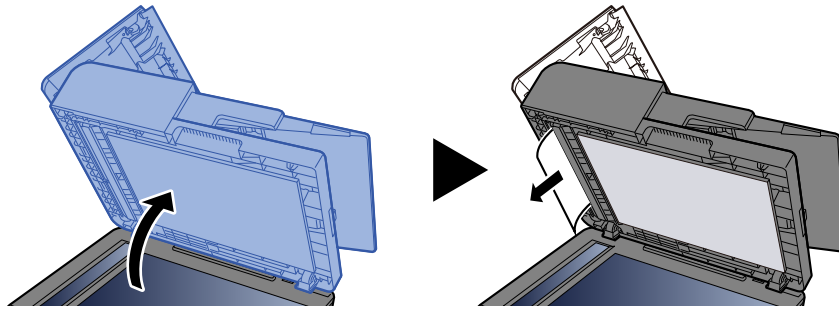

4 Return the cover to the original position.

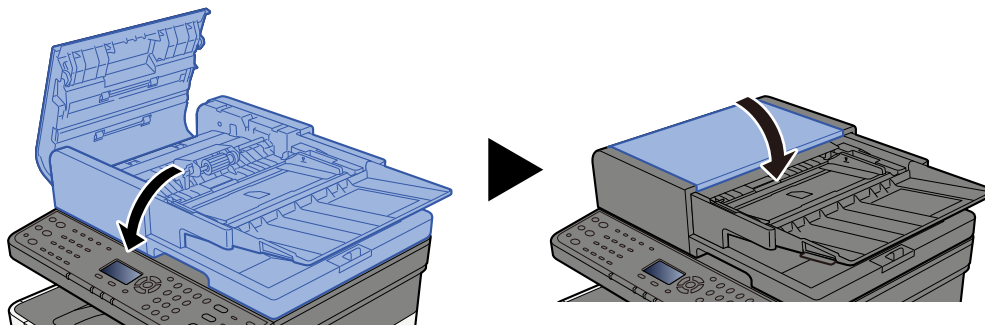

11 Appendix

Optional Equipment

Option configuration

The following enhancements are available for this model.

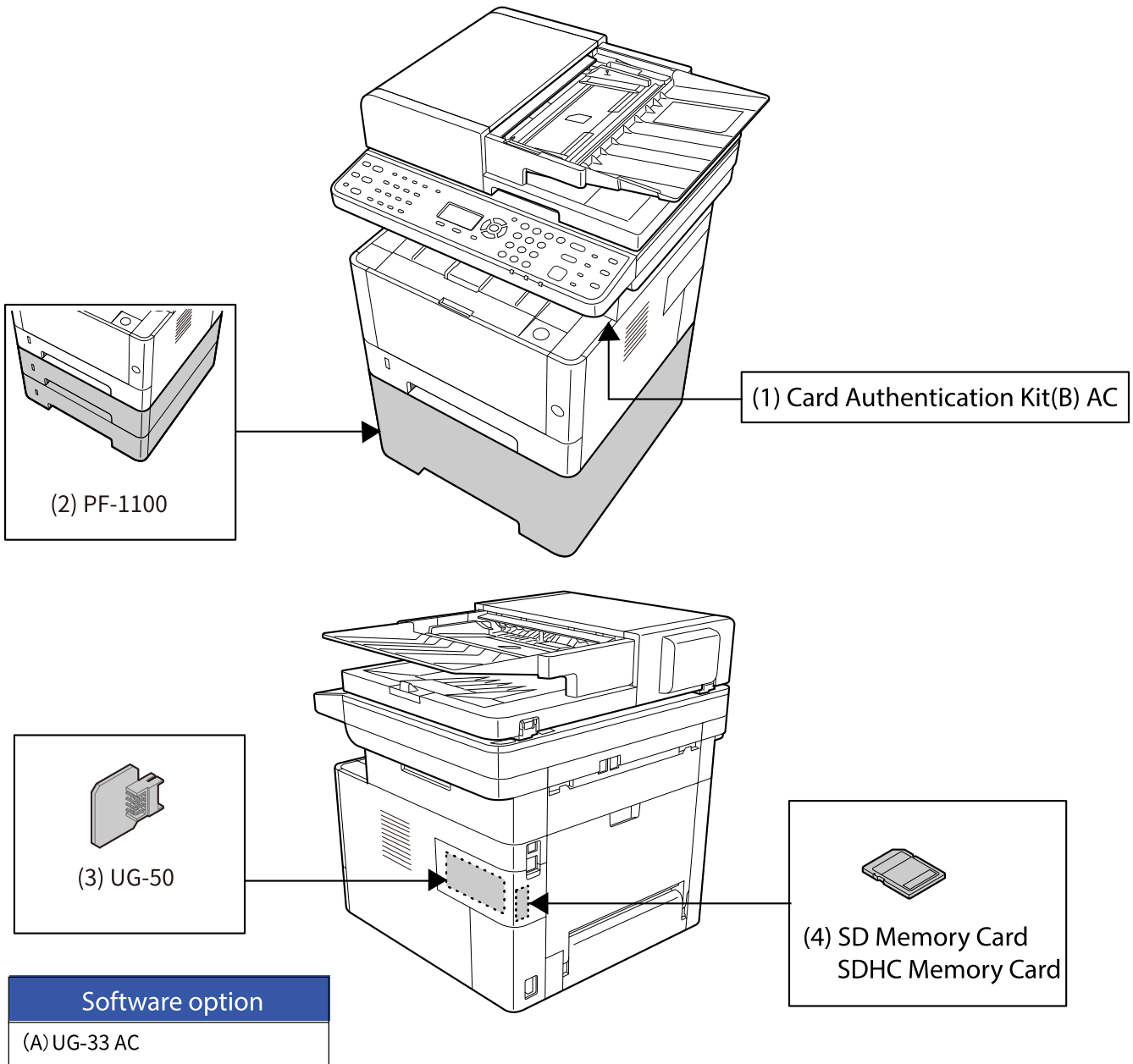

1 Card Authentication Kit(B) AC <IC card authentication kit (Activate)>

It is possible to make the user authentication with IC card. In order to perform the user authentication with IC card, IC card information has to be registered to the local user list in advance.

2 PF-1100 <Paper Feeder>

It is possible to add 2 drawers that is same as the cassette of the main unit.

The way of loading paper is same as the standard cassette.

3 UG-50 < Trusted Platform Module>

You can secure sensitive information with this option. The encryption key used to encrypt confidential information on this machine is stored in a dedicated storage area on the TPM chip. Since this storage area cannot be read from outside the TPM, confidential information can be safely protected.

4 SD/SDHC Memory Card

SD/SDHC memory card is the micro-chip card that the option font, macro, form, etc. can be written. Insert SDHC memory card (Max. 32GB) and SD memory card (Max. 2GB) into the memory card slot.



NOTE

If removing the TPM chip after the data encryption function is enabled, the machine will stop working.

Software option

1 UG-33 AC <ThinPrint expansion kit (Activate)>

It is possible print the print data directly even without the print driver.

Reading the SD/SDHC Memory Card

Once inserted in the machine's slot, the contents of the SD/SDHC memory card can be read from the operation panel or automatically when you power on or reset the machine.

Formatting the SD/SDHC Memory Card

To use an unused SD/SDHC Memory Card, you must first use the machine to format the SD/SD/SDHC Memory Card.

- 1 Turn off the power and disconnect the power cord and all cables connected to the unit.**
- 2 Open the cover.**

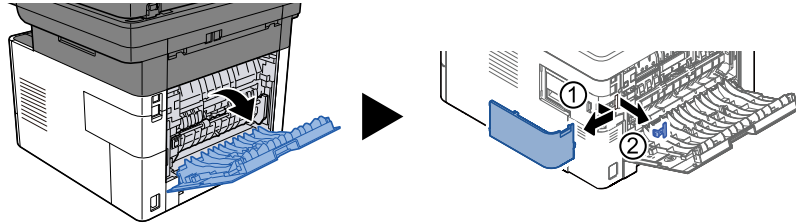

- 3 Insert SD/SDHC Memory Card into the memory card slot.**

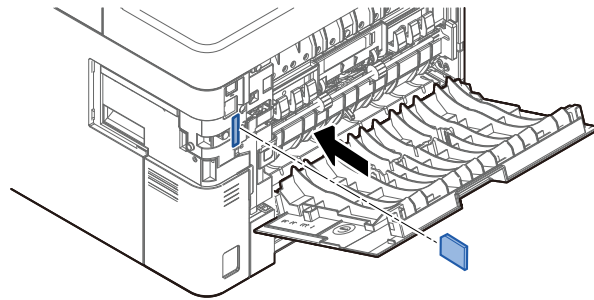

- 4 Attach the removed cover to the main unit.**

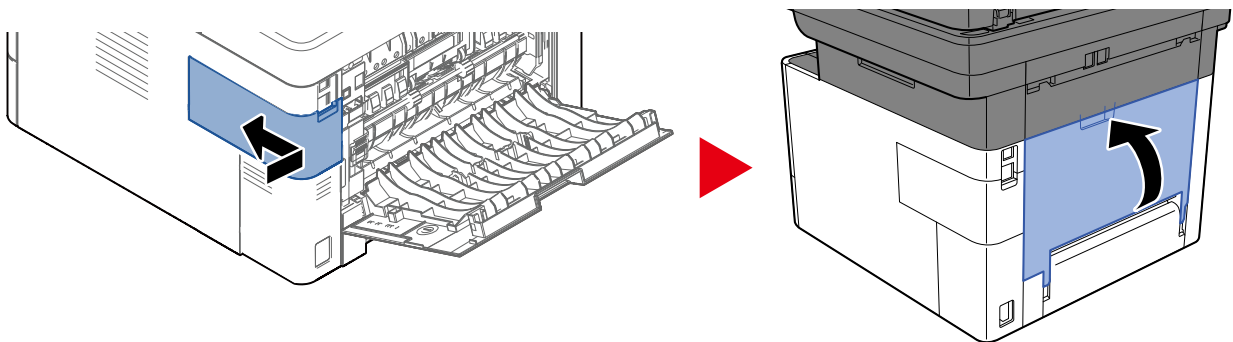

Overview of the Applications

The applications listed below are installed on this machine.

- ThinPrint expansion kit (Activate)ThinPrint expansion kit (Activate)
This can be used on a trial basis for a limited time.
- Authentication kit (Activate)
This can be used on a trial basis for a limited time.

NOTE

- Restrictions such as the number of times the application can be used during the trial period differ depending on the application.
 - If you change the date/time while using the trial version of an application, you will no longer be able to use the application.
-

Starting Application Use

1 Display the screen

[System Menu/Counter] key > [▲][▼] keys > [System/Network] > [OK] key

NOTE

If the user authentication screen appears, log in with a user who has the privilege to configure this setting. If you do not know your login user name or password, please contact your administrator.

2 [▲][▼] keys > [Op Functions] > [OK] key

3 Start up

- 1 Select the desired application and select the [OK] key.
- 2 [▲][▼] keys > [Official] > [OK] key
To use the application as a trial, select [Trial] without entering the license key.
- 3 Enter the license key > [OK] key
Some applications do not require you to enter a license key. If the license key entry screen does not appear, go to steps 2 to 4.
- 4 Select [Yes].

NOTE

If you start the ThinPrint Option and enter the license key, you need to turn the power OFF/ON.

Checking Details of Application

1 Display the screen

[System Menu/Counter] key > [▲] [▼] keys > [System/Network] > [OK] key

NOTE

If the user authentication screen appears, log in with a user who has the privilege to configure this setting. If you do not know your login user name or password, please contact your administrator.

2 [▲] [▼] keys > [Op Functions] > [OK] key

3 Check details

1 Select the desired application and select [Menu].

2 [▲] [▼] keys > [Detail] > [OK] key

NOTE

You can reference detailed information for the selected application.

Select the [▶] key to display the next page. Select the [◀] key to return to the previous page.

The items that can be referenced are as follows:

- Function Name
 - License On
 - Trial Counts
 - Date of Trial
 - Status
-

NOTE

To extend the trial period, select [▲] [▼] keys > [Trial] > [Extend] > [Yes].

Character Entry

The text entry screen used for entry of things like names is explained below.

NOTE

Kanji cannot be entered from the operation panel. You can enter kanji from your computer using Command Center RX or Kyocera Net Viewer.

→ [Accessing Command Center RX \(page 113\)](#)

Key used

Use the following keys enter characters.

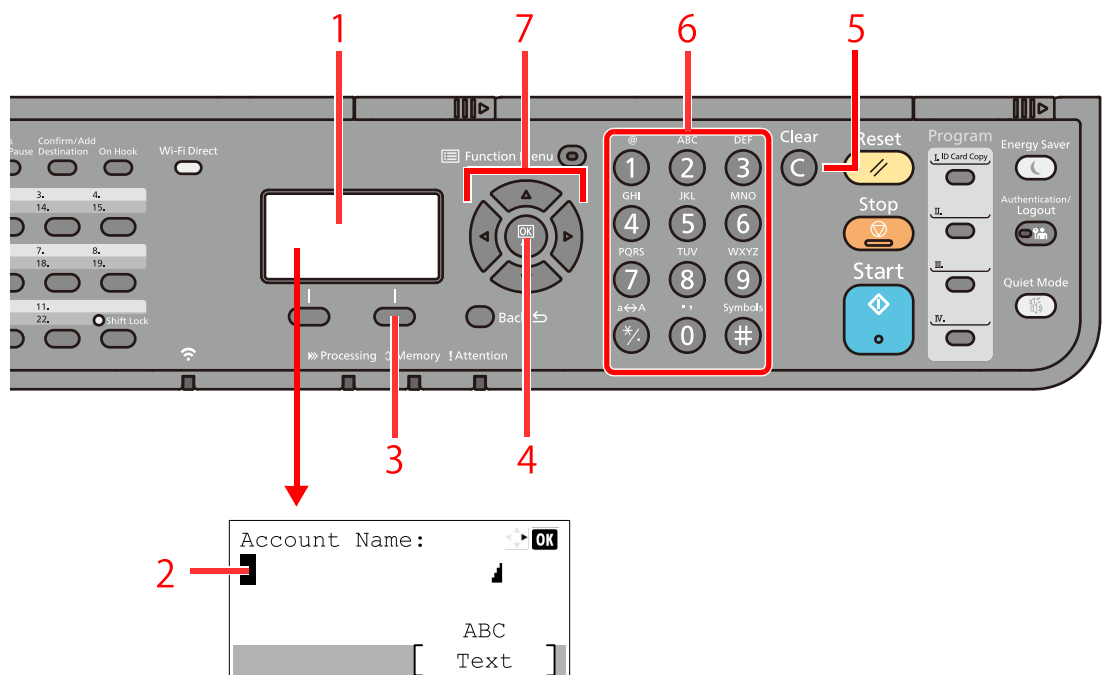

1 Message display

The entered text is displayed.

2 Cursor

Text will be entered at the position of the cursor.

3 Right selection key

Select if you are going to select the type for entered text.

Only enabled when the key tab is displayed on the message display.

4 [OK] key

Confirm the entered text.

5 [Clear] key

Confirm the entered text.

6 Numeric Keys

Select when moving the cursor of the text display portion or when selecting text from the text list.

7 Arrow keys

Select when moving the cursor of the text display portion or when selecting text from the text list.

Character Entry Selection

To enter characters, the following three types are available:

Types	Description
ABC	To enter alphabets.
123	To enter numerals.
Symbols	To enter symbols.





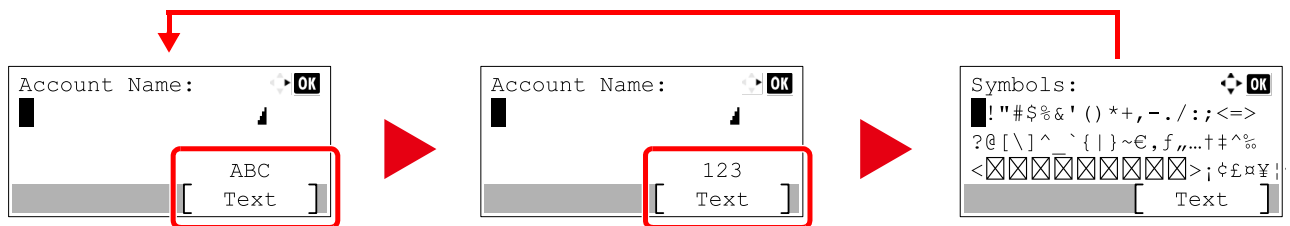



1 Switch input characters





Select [Text] on the character input screen, use the [▲][▼] keys to select the type of character you want to enter, and then select the [OK] key.



Entering numbers and alphabets

- 1 Refer to the table below and select the key that corresponds to the character you want to enter until that character appears.

Keys	Characters (Each press of a key changes the character in the order from left to right.)										
	.	@	-	_	/	:	~	1	(Repeats from the first character on the left)		
	1 (During number entry)										
	a	b	c	A	B	C	2	(Repeats from the first character on the left)			
	2 (During number entry)										
	d	e	f	D	E	F	3	(Repeats from the first character on the left)			
	3 (During number entry)										
	g	h	i	G	H	I	4	(Repeats from the first character on the left)			
	4 (During number entry)										
	j	k	l	J	K	L	5	(Repeats from the first character on the left)			
	5 (During number entry)										
	m	n	o	M	N	O	6	(Repeats from the first character on the left)			
	6 (During number entry)										
	p	q	r	s	P	Q	R	S	7	(Repeats from the first character on the left)	
	7 (During number entry)										
	t	u	v	T	U	V	8	(Repeats from the first character on the left)			
	8 (During number entry)										

Keys	Characters (Each press of a key changes the character in the order from left to right.)																	
	w	x	y	z	W	X	Y	Z	9	(Repeats from the first character on the left)								
	9 (During number entry)																	
	.	,	-	_	'	!	?	(space)	0	(Repeats from the first character on the left)								
	0 (During number entry)																	
	Select to change the character in the cursor position between upper case and lower case.																	
	"/" or "." (During number entry)																	
	!	"	#	\$	%	&	'	()	*	+	,	-	.	/	:	;	Displays the symbol list. For details, refer to the following: → Entering Symbols (page 11-10)
	<	=	>	?	@	[\]	^	_	`	{		}	~			
	# (During number entry)																	
* Depending on the functions, there are symbols that cannot be entered.																		

Entering Symbols

Symbols can be entered.

- 1 Select the [#] key. Displays the symbol list.

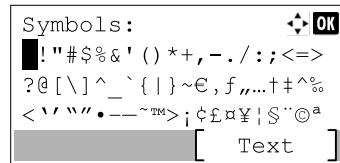

- 2 Select the [▲][▼][▶][◀] key to move the cursor and select the symbol to be entered.

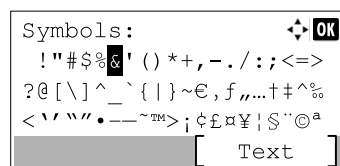

- 3 Select the [OK] key. The selected symbol is entered.

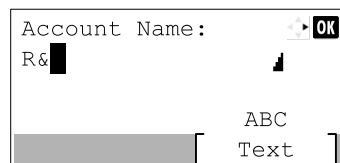

Entering Characters

Follow the steps shown below to enter "R&D" for example.

- 1 Select the [7] key three times. [r] is entered.

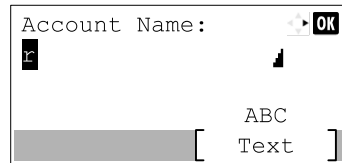

- 2 Select the [*/.] key. [r] changes to [R].

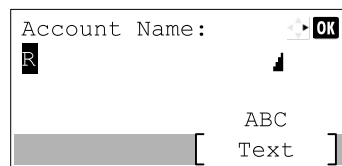

- 3 Select the [▶] key. The cursor moves to the right.

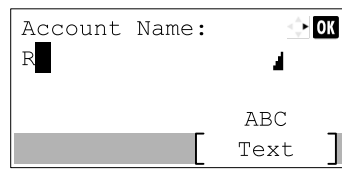

- 4 Select the [#] key. Displays the symbol list.

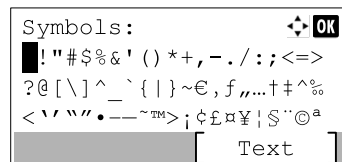

- 5 Select the [▲] or [▼] key to move the cursor and select [&].

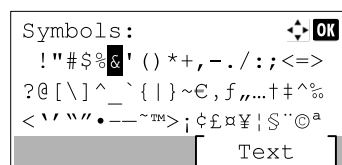

- 6 Select the [OK] key. [R&] is entered.

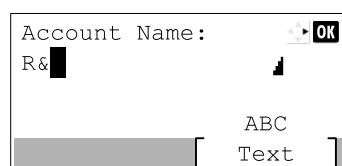

7 Select the [3] key four times. [D] is entered.

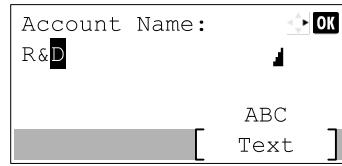

8 Select the [▶] key.

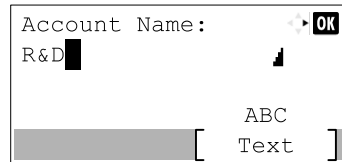

In the login operation settings, select and enter[Text]

The login screen displayed when user management is enabled may require different input methods depending on the settings.

For the procedure for configuring login operation settings, refer to the following:

→ [Login Operation \(page 452\)](#)

- 1 Select the [▲] [▼] [▶] [◀] key to move the cursor and select the character to be entered.

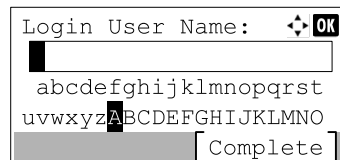

- 2 Select the [OK] key. The selected character is entered.

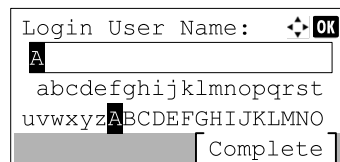

You can go back one character by selecting the [Clear] key.

- 3 When the entry is complete, select [Complete].

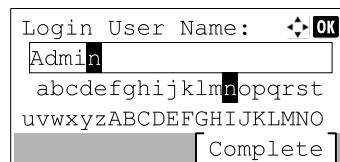

About Paper

This section explains the paper sizes and types that can be used in the paper source.

For details on the sizes, types, and number of sheets of paper that can be loaded in each paper tray, refer to the following:

→ [Specifications \(page 783\)](#)

Basic Paper Specifications

This machine is designed to print on standard copy paper as used in regular ('dry') copiers and page printers such as laser printers. It also supports a variety of other types of paper that conform to the specifications given in this appendix.

Be careful when choosing paper. Paper unsuitable for the machine may cause jams or may be wrinkled.

Supported Paper

Use standard copy paper for regular copiers or laser printers. The printing quality will be affected by the quality of paper. Poor quality paper may result in unsatisfactory output.

Basic Paper Specifications

The following table lists the specifications of paper that is supported with this machine.

Item	Specifications
Weight	Cassettes: 60 to 163 g/m ²
	Multipurpose tray: 60 to 220 g/m ²
Dimensional accuracy	±0.7 mm
Squareness of corners	90° ±0.2°
Moisture Content	4 to 6%
Pulp content	80% or more

NOTE

Some recycled paper does not meet requirements for use with this machine as listed in the Basic Paper Specifications shown below, such as moisture or pulp content. For this reason, we recommend purchasing a small amount of recycled paper as a sample for testing prior to use. Choose recycled paper that gives the best printing results and contains low levels of paper dust.

We are not responsible for the problems occurred from the use of paper that does not conform to our specifications.

Choosing the Appropriate Paper

This section describes guidelines for choosing paper.

Condition

Avoid using paper with bent corners or that is curled, dirty, or torn. Do not use paper that has a rough surface or paper fiber lint, or that is especially delicate. Using such paper can cause poor print quality. In addition, poor paper feeding can cause paper jams and shorten the life of the machine. Use paper with a smooth and even surface. However, do not use paper that has been surface-treated, such as coating, as it may damage the drum and fusing unit.

Ingredients

Do not use paper such as paper that has been coated or surface-treated or paper that contains plastic or carbon. Those types of paper may produce harmful fumes from the heat of printing and may damage the drum.

Be sure to use standard paper that contains at least 80% pulp. Be sure to use standard paper with 20% or less of the paper content consisting of cotton or other fibers.

Smoothness

The paper surface should be smooth, but it must be uncoated. With paper that is too smooth and slippery, several sheets may accidentally be supplied at once, causing jams. Basis Weight

In countries that use the metric system, basis weight is the weight in grams of one sheet of paper one square meter in area.

In the United States, basis weight is the weight in pounds of one ream (500 sheets) of paper cut to the standard size (or trade size) for a specific grade of paper.

Paper that is too heavy or too light may be supplied incorrectly or cause paper jams, which may cause excessive wear of the machine. Mixed paper weight (i.e., thickness) may cause several sheets to be supplied at once accidentally and may also cause blurring or other printing problems if the toner fails to adhere correctly.

Moisture Content

Paper moisture content is the ratio of moisture to dryness expressed as a percentage. Moisture affects how the paper is supplied, the electrostatic chargeability of the paper, and how the toner adheres.

Paper moisture content varies depending on the relative humidity in the room. High relative humidity causes paper to become damp, making the edges expand so it appears wavy. Low relative humidity causes paper to lose moisture, making the edges tighten and weakening print contrast.

Wavy or tight edges may cause the paper to slip when it is supplied. Try to keep the moisture content between 4 to 6%.

To maintain the right level of moisture content, bear in mind the following considerations.

- Store paper in a cool, well-ventilated place.
- Store paper flat and unopened in the package. Once the package is opened, reseal it if the paper is not to be used for a while.
- Store paper sealed in the original package and box. Put a pallet under the box to keep it raised above the floor. Especially during rainy seasons keep the paper a sufficient distance away from wooden or concrete floors.
- Before using paper that has been stored, keep it at the proper moisture level for at least 48 hours.
- Do not store paper where it is exposed to heat, sunlight, or dampness.

Other Paper Specifications

Porosity:

The density of the paper fibers.

Stiffness:

Paper must be stiff enough or it may buckle in the machine, causing jams.

Curl:

Most paper naturally tends to curl after the package is opened. When paper passes through the fixing unit, it curls upward slightly. To deliver flat printouts, load the paper so that the curl faces towards the bottom of the paper tray.

Static electricity:

During printing, paper is electrostatically charged so that the toner adheres. Choose paper that can be discharged quickly so that copies do not cling together.

Whiteness:

Paper whiteness affects print contrast. Use whiter paper for sharper, brighter copies.

Quality:

Machine problems may occur if sheet sizes are not uniform or if corners are not square, edges are rough, sheets are uncut, or edges or corners are crushed. In order to prevent these problems, be especially careful when you cut the paper yourself.

Packaging:

Choose paper that is properly packaged and stacked in boxes. Ideally, the packaging itself should have been treated with a coating to inhibit moisture.

Specially treated paper:

We do not recommend printing onto the following types of paper, even if it conforms to the basic specifications. When you use these kinds of paper, purchase a small amount first as a sample to test.

- Glossy paper
- Watermarked paper
- Paper with an uneven surface
- Perforated paper

Paper Sizes that can be Used with This Machine

Paper of the following sizes is supported by the machine.

Measurements in the table take into account a ± 0.7 mm dimensional accuracy for length and width. Corner angles must be $90^\circ \pm 0.2^\circ$.

Paper Size	Cassette 1 to 3	MultipurposeTray
Envelope Monarch (3-7/8 × 7-1/2")	Paper of this size cannot be set	Paper of this size can be set
Envelope #10 (4-1/8 × 9-1/2")	Paper of this size cannot be set	Paper of this size can be set
Envelope DL (110 × 220 mm)	Paper of this size cannot be set	Paper of this size can be set
Envelope C5 (162 × 229 mm)	Paper of this size cannot be set	Paper of this size can be set
Executive (7-1/4 × 10-1/2")	Paper of this size can be set	Paper of this size can be set
Letter	Paper of this size can be set	Paper of this size can be set
Legal	Paper of this size can be set	Paper of this size can be set

Paper Size	Cassette 1 to 3	MultipurposeTray
A4 (297 × 210 mm)	Paper of this size can be set	Paper of this size can be set
B5 (257 × 182 mm)	Paper of this size can be set	Paper of this size can be set
A5-R	Paper of this size can be set	Paper of this size can be set
A5 (210 × 148 mm)	Paper of this size can be set	Paper of this size can be set
A6 (148 × 105 mm)	Paper of this size can be set	Paper of this size can be set
B6 (182 × 128 mm)	Paper of this size cannot be set	Paper of this size can be set
Envelope #9 (3-7/8 × 8-7/8")	Paper of this size cannot be set	Paper of this size can be set
Envelope #6 (3-5/8 × 6-1/2")	Paper of this size cannot be set	Paper of this size can be set
ISO B5 (176 × 250 mm)	Paper of this size can be set	Paper of this size can be set
Hagaki (Cardstock) (100 × 148 mm)	Paper of this size cannot be set	Paper of this size can be set
Oufuku hagaki (Return postcard) (148 × 200 mm)	Paper of this size cannot be set	Paper of this size can be set
Oficio II	Paper of this size can be set	Paper of this size can be set
216 × 340 mm	Paper of this size can be set	Paper of this size can be set
16K (273 × 197 mm)	Paper of this size can be set	Paper of this size can be set
Statement	Paper of this size can be set	Paper of this size can be set
Folio (210 × 330 mm)	Paper of this size can be set	Paper of this size can be set
Youkei 4 (105 × 235 mm)	Paper of this size cannot be set	Paper of this size can be set
Youkei 2 (114 × 162 mm)	Paper of this size cannot be set	Paper of this size can be set
Nagagata 3	Paper of this size cannot be set	Paper of this size can be set
Nagagata 4	Paper of this size cannot be set	Paper of this size can be set
Yougata 3	Paper of this size cannot be set	Paper of this size can be set
Size Input	Cassette: 105×148 to 216×356 mm Multipurpose Tray: 70 × 148 to 216 × 356 mm	

Special Paper

This section describes printing onto special paper and print media.

The following paper and media can be used.

- Transparencies
- Preprint
- Bond paper
- Recycled paper
- Thin paper
- Letterhead
- Colored Paper
- Prepunched paper
- Envelopes
- Hagaki (Cardstock)
- Thick Paper
- Labels
- Coated Paper
- High-quality paper

When using these paper and media, choose those that are designed specifically for copiers or page printers (such as laser printers). Use the multipurpose tray for thick paper, envelopes, cardstocks, and label paper.

Choosing Special Paper

Although special paper that meets the following requirements can be used with the machine, print quality will vary considerably due to differences in the construction and quality of special paper. Thus, special paper is more likely than regular paper to cause printing problems. Before purchasing special paper in volume, try testing a sample to ensure the print quality is satisfactory. General precautions when printing onto special paper are given below. Note that we are not responsible for any harm to the user or damage to the machine caused by moisture or specifications of special paper.

Select a cassette or multipurpose tray for special paper.

Transparencies

Transparencies must be able to withstand the heat of printing. Transparencies must meet the following conditions.

Heat resistance	Must withstand at least 190°C
Thickness	0.100 to 0.110 mm
Material	Polyester
Dimensional accuracy	±0.7 mm
Squareness of corners	90° ±0.2°

If transparencies jam frequently at output, try pulling the leading edge of sheets gently as they are ejected.

Labels

Be sure to feed labels from the multipurpose tray

For selecting labels, use extreme care so that the adhesive may not come in direct contact with any part of the machine and that the labels are not easily peeled from the carrier sheet. Adhesives that stick to the drum or rollers and peeled labels remaining in the machine may cause a failure.

When printing onto labels, you must be liable for the print quality and possible trouble.



Labels consist of three layers as shown in the illustration. The adhesive layer contains materials that are easily affected by the force applied in the machine. The carrier sheet bears the top sheet until the label is used. This composition of labels may cause more problems.

The label surface must be covered completely with the top sheet. Gaps between labels may cause peeling of labels, resulting in a serious failure.

Some label paper has large margins on the top sheet. When using such paper, do not peel these margins from the carrier sheet before completing output.

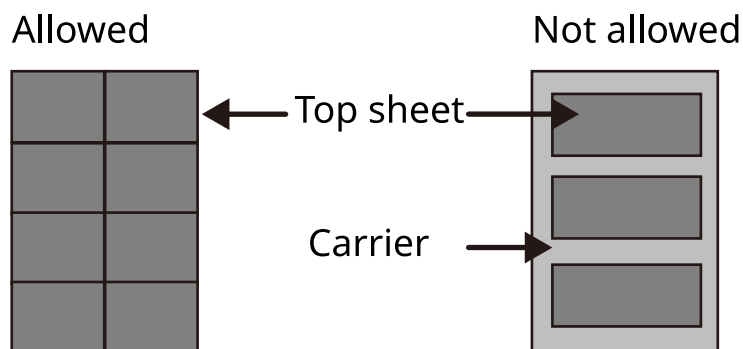

Use label paper that conforms to the following specifications.

Top sheet weight	44 to 74 g/m ²
Basis weight(overall paper weight)	104 to 151 g/m ²
Top sheet thickness	0.086 to 0.107 mm
Overall paper thickness	0.115 to 0.145 mm
Moisture Content	4 to 6 % (composite)

Hagaki (Cardstock)

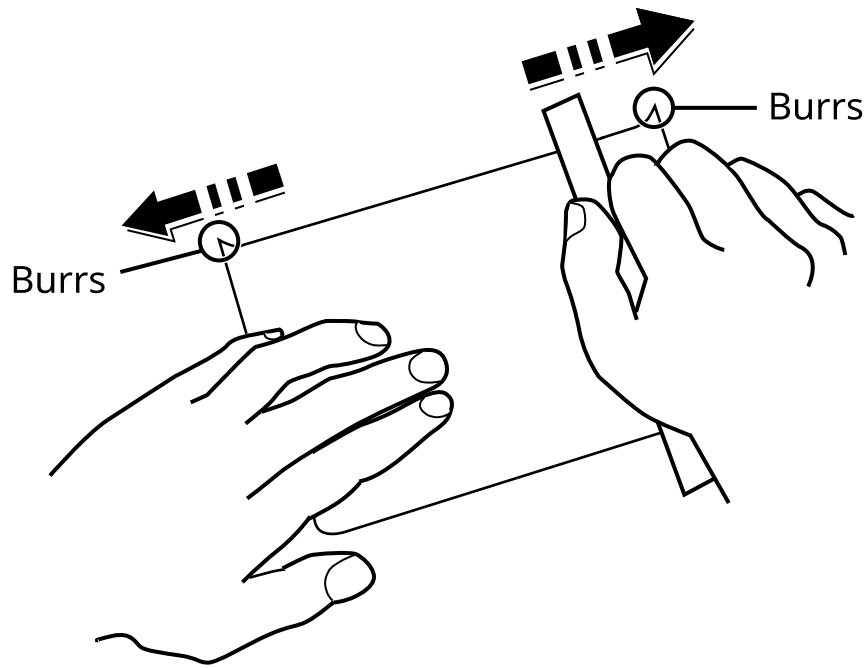

Before loading Hagaki (Cardstock) into the multipurpose tray, fan them and align the edges. If the Hagaki (Cardstock) paper is curled, straighten it before loading. Printing onto curled Hagaki (Cardstock) may cause jams.

Use unfolded Oufuku hagaki (Return postcard) (available at post offices). Some Hagaki (Cardstock) may still have rough edges developed by a paper cutter on the back side. Remove any such rough edges by placing the Hagaki (Cardstock) on a flat surface and rubbing the edges gently a few times with a ruler.

Envelopes

Envelopes should be fed from the MP tray with the print-side down or the cassette and the optional paper feeder with the print-side up.

NOTE

Do not load paper above the load limits located on the paper width guide of the cassette and the optional paper feeder.

Due to the structure of envelopes, printing evenly over the entire surface may not be possible in some cases. Thin envelopes in particular may be wrinkled by the machine in some cases as they pass through. Before purchasing envelopes in volume, try testing a sample to ensure the print quality.

Storing envelopes for a long period may cause them to become wrinkled. Thus, keep the package sealed until you are ready to use them.

Keep the following points in mind.

- Do not use envelopes with exposed adhesive. In addition, do not use the type of envelope in which the adhesive is exposed after the top layer is peeled off. Serious damage may be caused if the paper covering the adhesive comes off in the machine.
- Do not use envelopes with certain special features. For example, do not use envelopes with a grommet for winding a string to close the flap or envelopes with an open or film-covered window.
- If paper jams occur, load fewer envelopes at once.

Thick Paper

Before loading thick paper, fan it and align the edges. Some thick paper may still have rough edges developed by a paper cutter on the back side. Remove any such rough edges just as with Hagaki (Cardstock) by placing the paper on a flat surface and rubbing the edges gently a few times with a ruler. Printing onto paper with rough edges may cause jams.



NOTE

If the paper is not supplied correctly even after it is smoothed, load the paper with the leading edge raised a few millimeters.

Colored Paper

Colored paper must conform to the specifications.

➔ [Basic Paper Specifications \(page 769\)](#)

In addition, the pigments in the paper must be able to withstand the heat of printing (up to 200°C or 392°F).

Preprint

Preprinted paper must conform to the specifications

➔ [Basic Paper Specifications \(page 769\)](#)

The colored ink must be able to withstand the heat of printing. It must be resistant to silicone oil as well. Do not use paper with a treated surface such as glossy paper used for calendars.

Recycled paper

Recycled paper must conform to the specifications; however, its whiteness may be considered separately.

➔ [Basic Paper Specifications \(page 769\)](#)



NOTE

Before purchasing recycled paper in volume, try testing a sample to ensure satisfactory print quality.

Coated Paper

Coated paper is created by treating the surface of the base paper with a coating that provides higher printing quality than plain paper. Coated paper is used for particularly high quality printing.

The surface of high-quality or medium-quality paper is coated with special agents that improve ink adhesion by making the paper surface smoother. These agents are used either to coat both sides of the paper or just one side. The coated side appears slightly glossy.

IMPORTANT

When printing on coated paper in very humid environments, ensure that the paper is kept dry as moisture may cause sheets to stick together when they are fed into the machine. If printing in very humid environments, set coated paper for one sheet each.

Specifications

IMPORTANT

Specifications are subject to change without notice.

NOTE

For more information on using the FAX, refer to the following:

➔ [FAX Operation Guide](#)

Machine

Item	Specifications
Type	Desktop
Printing Method	Electrophotography by semiconductor laser
Paper Weight (Cassette)	60 to 163 g/m ²
Paper Weight (Multipurpose Tray)	60 to 220 g/m ² , 209.5 g/m ² (Postal card)
Paper Type (Cassette)	Plain, Recycled, Preprinted, Bond, Color, Prepunched, Letterhead, Thick, High Quality, Custom 1 to 8 (Duplex printing is same as single-sided)
Paper Type (Multipurpose Tray)	Plain, Transparency, Labels, Recycled, Preprinted, Bond, Cardstock, Color, Prepunched, Letterhead, Envelope, Thick Paper, High Quality, Custom 1 to 8
Paper Size (Cassette)	A4, A5-R, A5, A6, B5, Letter, Legal, Folio, 216 x 340 mm, Statement, Executive, Oficio II, 16K, B5 (ISO), Custom (105 x 148 to 216 x 356 mm)
Paper Size (Multipurpose Tray)	A4, A5-R, A5, A6, B5, Letter, Legal, Folio, 216 x 340 mm, Statement, Executive, Oficio II, 16K, B5 (ISO), Envelope #10, Envelope #9, Envelope #6 3/4, Envelope Monarch, Envelope DL, Envelope C5, postcard, return postcard, Yougata 4, Yougata 2, Nagagata 3, Nagagata 4, Younaga 3, Custom (70 x 148 to 216 x 356 mm)
Print image width	Full surface 4.2 mm
Warm-up Time (23°C/73.4°F, 60%)	19 seconds or less (from power ON)
Paper Capacity (Cassette)	250 sheets (80 g/m ²)
Paper Capacity (Multipurpose Tray)	100 sheets (80 g/m ²)
Output Tray Capacity (Upper tray)	150 sheets (80 g/m ²)
Image Write System	Semiconductor laser and electrophotography
Memory	1GB

Item	Specifications
Interface	<ul style="list-style-type: none"> • Hi-Speed USB: 1 • Network interface: 1 (10 BASE-T/100 BASE-TX/1000 BASE-T) • 1 (Hi-Speed USB) • Wireless LAN compatible • Fax: 1
Operating Environment (Temperature)	10 to 32.5 °C
Operating Environment (Humidity)	10 to 80 %
Operating Environment (Altitude)	3,500 m/11,482 ft maximum
Operating Environment (Brightness)	1,500 lux maximum
Dimension (W × D × H)	375 x 393 x 272 mm; 475 × 412 × 437 mm; 417 × 412 × 437 mm
Weight (without toner container)	19 kg
Space Required (W × D) (when using multipurpose tray)	475 x 548 mm
Power Source	AC120 V, 60Hz, 8.9 A
The power consumption of the product in networked standby (If all network ports are connected.)	<p>The information is available at the website below.</p> <p>https://www.kyoceradocumentsolutions.eu/en/about-us/our-brand/environmental-policy.html</p>
Options	➔ Option configuration (page 756)

Copy Functions

Copy Speed

Paper Size	Specifications
A4	40 sheets/min
LetterR	42 sheets/min
B5R	15 sheets/min ^{*1}
A5R	15 sheets/min ^{*2}
A6R	19 sheets/min ^{*3}
Legal	34 sheets/min
A5	65 sheets/min
16K	12.5 sheets/min ^{*4}

* 1: 8.5 sheets / min. for the 5th page and after

* 2: 8.5 sheets / min. for the 6th page and after

* 3: 8.5 sheets / min. for the 7th page and after

* 4: 7.5 sheets / min. for the 5th and after

Others

Item	Specifications
First Copy Time (A4, placed on the platen, feed from Cassette)	6.4 seconds or less
Zoom Level	Manual mode: 25 to 400%, 1% increments Preset zoom levels: 400%, 200%, 141%, 115%, 100%, 86%, 70%, 50%, 25%
Continuous Copying	1 to 999 sheets
Resolution	600 × 600 dpi
Original Type	Sheet, Book, 3-dimensional objects (maximum original size: 216×356 mm)
Original Feed System	Fixed

Printer Function

Print Speed

Paper Size	Specifications
A4	40 sheets/min
Letter	42 sheets/min
B5R	9.5 sheets/min ^{*1}
A5R	9.5 sheets/min ^{*2}
A6R	11 sheets/min ^{*3}
Legal	34 sheets/min
A5	65 sheets/min
16K	8.5 sheets/min ^{*4}

* 1: 15 sheets/min until the 4th, 8.5 sheets/min from the 5th and after

* 2: 15 sheets/min until the 5th, 8.5 sheets/min from the 6th and after

* 3: 19 sheets/min until the 6th, 8.5 sheets/min from the 7th and after

* 4: 12.5 sheets/min until the 4th, 7.5 sheets/min from the 5th and after

Others

Item	Specifications
First Print Time (A4, feed from Cassette)	6.4 seconds or less
Resolution	600 × 600 dpi
Operating System	<ul style="list-style-type: none"> • Windows 10 • Windows 11 • Windows Server 2016 • Windows Server 2019 • Windows Server 2022 • Mac OS X v10.9 or higher
Interface	<ul style="list-style-type: none"> • Hi-Speed USB: 1 • Network interface: 1 (10 BASE-T/100 BASE-TX/1000 BASE-T) • Wireless LAN: 1 (For wireless network model)
Page Description Language	PRESCRIBE
Emulation	<ul style="list-style-type: none"> • PCL6 (PCL-XL, PCL5c) • KPDL3 (Postscript3 compatible) • XPS • OpenXPS • PDF

Scanner Functions

Scanning Speed (A4 landscape, 300 dpi, Image quality: Text/Photo original)

When using the document processor (except TWAIN scanning)

Item	Black and White	Color
1-Sided	40 sheets/min	23 sheets/min
2-Sided	80 sheets/min	46 sheets/min

Others

Item	Specifications
Resolution	<ul style="list-style-type: none"> • 200 dpi x 200 dpi (Default) • 300 dpi x 300 dpi • 200dpi x 100dpi • 600dpi x 600dpi • 400dpi x 400dpi • 200dpi x 400dpi
File Format	TIFF (MMR/JPEG compression), JPEG, PDF (MMR/JPEG compression), XPS, PDF/A, High-Compression PDF, Encrypted PDF, Open XPS
Interface	Ethernet (10 BASE-T/100 BASE-TX/1000 BASE-T), USB
Transmission System	SMB, SMTP, FTP, FTP over SSL, USB, TWAIN, WIA, WSD, eSCL

Available Operating Systems: Windows 10/Windows 11/Windows Server 2016/Windows Server 2019/Windows Sever 2022

Document Processor

Item	Specifications
Original Type	Sheet originals
Original Size	Maximum: Legal/Folio Minimum: A6/Statement
Original Weight	50 to 160 g/m ²
Loading Capacity	50 sheets (50 to 80 g/m ²) maximum Thick paper: 25 sheets

Paper Feeder (300 250 sheet x 2)

Item	Specifications
Paper Supply Method	Friction roller feeder Capacity 250 sheets (80 g/m ²) × up to 2 cassettes
Paper Size	A4, A5-R, A5, A6, B5, Letter, Legal, Folio, 216 x 340 mm, Statement, Executive, Oficio II, 16K, B5 (ISO), Custom (105 x 148 to 216 x 356 mm)
Supported Paper	Paper thickness: 60 to 163 g/m ² Paper Type: Plain Paper, Recycled Paper, Preprint, Bond Paper, Color Paper, Punched Paper, Letterhead, Thick Paper, Fine Paper, Custom
Dimensions (W × D × H)	375 × 393 × 100 mm / 14.76" × 15.47" × 3.94"
Weight	2.9kg / 6.39lb

Backing up your data

If the memory of this machine installed in the machine failed for any reason, the files in the box and various settings saved there will be deleted and cannot be restored. To prevent erasing data, make regular backups as follows.

- Take a backup using KYOCERA Net Viewer.
 - ➔ [Backing up your data using KYOCERA Net Viewer \(page 790\)](#)

Backing up your data using KYOCERA Net Viewer

Use KYOCERA Net Viewer to regularly back up the data below that is saved on the machine.

- System Settings
- Network Settings
- User List

Backing up your data using USB Drive

You can copy the data saved in the Subaddress Box to a USB drive. You can save multiple document data at once.

➔ [Backing up your data using USB Drive \(page 791\)](#)

Security Quick Setup Function List

The functions configured in each level of Security Quick Setup are as follows. After selecting the security level, configure the security function according to your operating environment.

TLS

Level 1	Level 2	Level 3
On	On	On

Serverside Settings

The setting item which can be set or configured from Command Center RX.

TLS Version

Level 1	Level 2	Level 3
TLS1.2, TLS1.3	TLS1.2, TLS1.3	TLS1.2, TLS1.3

Effective Encryption

Level 1	Level 2	Level 3
3DES, AES, AES-GCM, CHACHA20/ POLY1305	AES-GCM, AES, CHACHA20/ POLY1305	AES-GCM, AES, CHACHA20/ POLY1305

Hash

level 1	level 2	level 3
SHA1, SHA-2(256/384)	SHA-2(256/384)	SHA-2(256/384)

IPP Security

Level 1	Level 2	Level 3
Secure Only (IPPS)	Secure Only (IPPS)	Secure Only (IPPS)

HTTP Security

Level 1	Level 2	Level 3
Secure Only (HTTPS)	Secure Only (HTTPS)	Secure Only (HTTPS)

Enhanced WSD Security

Level 1	Level 2	Level 3
Secure Only (Enhanced WSD over TLS)	Secure Only (Enhanced WSD over TLS)	Secure Only (Enhanced WSD over TLS)

eSCL Security

Level 1	Level 2	Level 3
Secure Only (eSCL over TLS)	Secure Only (eSCL over TLS)	Secure Only (eSCL over TLS)

REST Security

Level 1	Level 2	Level 3
Secure Only (REST over TLS)	Secure Only (REST over TLS)	Secure Only (REST over TLS)

Clientside Settings

The setting item which can be set or configured from Command Center RX.

TLS Version

Level 1	Level 2	Level 3
TLS1.2, TLS1.3	TLS1.2, TLS1.3	TLS1.2, TLS1.3

Effective Encryption

Level 1	Level 2	Level 3
3DES, AES, AES-GCM, CHACHA20/ POLY1305	AES-GCM, AES, CHACHA20/ POLY1305	AES-GCM, AES, CHACHA20/ POLY1305

Hash

level 1	level 2	level 3
SHA1, SHA-2(256/384)	SHA-2(256/384)	SHA-2(256/384)

IPv4 Settings (Wired Network)

The setting item which can be set or configured from Command Center RX.

DNS over TLS

level 1	level 2	level 3
Off	Auto	On

Certificate Auto Verification

level 1	level 2	level 3
Expiration Date	Expiration Date	Expiration Date

Hash

level 1	level 2	level 3
SHA-2(256/384)	SHA-2(256/384)	SHA-2(256/384)

IPv4 Settings (Wireless Network)

The setting item which can be set or configured from Command Center RX.

DNS over TLS

level 1	level 2	level 3
Off	Auto	On

Certificate Auto Verification

level 1	level 2	level 3
Expiration Date	Expiration Date	Expiration Date

Hash

level 1	level 2	level 3
SHA-2(256/384)	SHA-2(256/384)	SHA-2(256/384)

IPv6 Settings (Wired Network)

The setting item which can be set or configured from Command Center RX.

DNS over TLS

level 1	level 2	level 3
Off	Auto	On

Certificate Auto Verification

level 1	level 2	level 3
Expiration Date	Expiration Date	Expiration Date

Hash

level 1	level 2	level 3
SHA-2(256/384)	SHA-2(256/384)	SHA-2(256/384)

IPv6 Settings (Wireless Network)

The setting item which can be set or configured from Command Center RX.

DNS over TLS

level 1	level 2	level 3
Off	Auto	On

Certificate Auto Verification

level 1	level 2	level 3
Expiration Date	Expiration Date	Expiration Date

Hash

level 1	level 2	level 3
SHA-2(256/384)	SHA-2(256/384)	SHA-2(256/384)

Send Protocols: FTP Client (Transmission)

The setting item which can be set or configured from Command Center RX.

Certificate Auto Verification

level 1	level 2	level 3
Expiration Date	Expiration Date	Expiration Date

Hash

level 1	level 2	level 3
SHA-2(256/384)	SHA-2(256/384)	SHA-2(256/384)

Other Protocols: HTTP (Client)

The setting item which can be set or configured from Command Center RX.

Certificate Auto Verification

level 1	level 2	level 3
Expiration Date	Expiration Date	Expiration Date

Hash

level 1	level 2	level 3
SHA-2(256/384)	SHA-2(256/384)	SHA-2(256/384)

Other Protocols: SOAP

The setting item which can be set or configured from Command Center RX.

Use Default Settings

Level 1	Level 2	Level 3
On	On	On

Other Protocols: LDAP

The setting item which can be set or configured from Command Center RX.

Use Default Settings

Level 1	Level 2	Level 3
Off	Expiration Date	Expiration Date

Send Protocols: SMTP (E-mail TX)

The setting item which can be set or configured from Command Center RX.

Certificate Auto Verification

level 1	level 2	level 3
Expiration Date	Expiration Date	Expiration Date

Hash

level 1	level 2	level 3
SHA-2(256/384)	SHA-2(256/384)	SHA-2(256/384)

Email: POP3 User Settings

The setting item which can be set or configured from Command Center RX.

Certificate Auto Verification

level 1	level 2	level 3
Expiration Date	Expiration Date	Expiration Date

Hash

level 1	level 2	level 3
SHA-2(256/384)	SHA-2(256/384)	SHA-2(256/384)

Print protocols

SMB Server Protocol

level 1	level 2	level 3
Off	Off	Off

LPD

Level 1	Level 2	Level 3
On	On	Off

FTP (Receiving)

Level 1	Level 2	Level 3
On	Off	Off

IPP

Level 1	Level 2	Level 3
On	Off	Off

IPP over TLS

Level 1	Level 2	Level 3
On	On	On

Raw

Level 1	Level 2	Level 3
On	On	Off

ThinPrint

Level 1	Level 2	Level 3
On	Off	Off

ThinPrint over TLS

Level 1	Level 2	Level 3
On	__*1	__*1

*1 If you select [Level 2] or [Level 3] in "SecurityQuickSet", this setting will disappear.

WSD Print

Level 1	Level 2	Level 3
On	Off	Off

POP (E-mail RX)

Level 1	Level 2	Level 3
Off	Off	Off

Send Protocol

FTP Client (Transmission)

Level 1	Level 2	Level 3
On	Off	Off

SMB

Level 1	Level 2	Level 3
On	On	Off

WSD Scan

Level 1	Level 2	Level 3
On	Off	Off

eSCL

Level 1	Level 2	Level 3
On	Off	Off

eSCL over TLS

Level 1	Level 2	Level 3
On	On	Off

Other Protocols

SNMPv1/v2c

Level 1	Level 2	Level 3
On	On	Off

SNMPv3

Level 1	Level 2	Level 3
Off	Off	Off

HTTP

Level 1	Level 2	Level 3
On	Off	Off

HTTPS

Level 1	Level 2	Level 3
On	On	On

Enhanced WSD

Level 1	Level 2	Level 3
On	Off	Off

Enhanced WSD (TLS)

Level 1	Level 2	Level 3
On	On	On

LDAP

Level 1	Level 2	Level 3
Off	Off	Off

LLTD

Level 1	Level 2	Level 3
Off	Off	Off

REST

Level 1	Level 2	Level 3
On	Off	Off

REST over TLS

Level 1	Level 2	Level 3
On	On	On

VNC (RFB)

Level 1	Level 2	Level 3
Off	Off	Off

VNC (RFB) over TLS

Level 1	Level 2	Level 3
Off	Off	Off

Enhanced VNC (RFB) over TLS

Level 1	Level 2	Level 3
On	Off	Off

TCP/IP: Bonjour Settings

Bonjour

Level 1	Level 2	Level 3
On	On	Off

Network Settings

Wi-Fi Direct Settings

Level 1	Level 2	Level 3
Off	Off	Off

Connectivity

Bluetooth Settings

Level 1	Level 2	Level 3
Off	Off	Off

Interface Block Setting

USB Host

Level 1	Level 2	Level 3
Unblock	Unblock	Block

USB Device

Level 1	Level 2	Level 3
Unblock	Unblock	Block

USB Drive

Level 1	Level 2	Level 3
Unblock	Unblock	Block

Energy Saver/Timer

Auto Panel Reset

Level 1	Level 2	Level 3
On	On	On

User Account Lockout Setting

Lockout

level 1	level 2	level 3
Off	Off	On

Job Status/Job Logs Settings

Display Jobs Detail Status

Level 1	Level 2	Level 3
Show All	Show All	Hide All (Display only when Administrator)

Display Jobs Log

Level 1	Level 2	Level 3
Show All	Show All	Hide All (Display only when Administrator)

Display Fax Log

Level 1	Level 2	Level 3
Show All	Show All	Hide All (Display only when Administrator)

Edit Restriction

Address Book

Level 1	Level 2	Level 3
No limit	No limit	Administrator only

One-Touch Key

Level 1	Level 2	Level 3
No limit	No limit	Administrator only

Prevent Mis-sending Settings

Destination Check before Send

Level 1	Level 2	Level 3
On	On	On

Entry Check for New Dest.

Level 1	Level 2	Level 3
On	On	On

New Destination Entry

Level 1	Level 2	Level 3
Permit	Permit	Prohibit

New destination entry (FAX)

Level 1	Level 2	Level 3
Permit	Permit	—*1

*1 If you select in , this setting will disappear.

Recall Destination

Level 1	Level 2	Level 3
Prohibit	Permit	Prohibit

Broadcast

Level 1	Level 2	Level 3
Permit	Permit	Prohibit

For the Kyocera contact in your region, see Sales Sites sections here.
<https://www.kyoceradocumentsolutions.com/company/directory.html>